

**THE SYNTAX OF VERBAL INFLECTION
IN CENTRAL KURDISH**

Rebeen Kareem

A thesis submitted in partial fulfilment of the requirements for the
Degree of Doctor of Philosophy

School of English Literature, Language and Linguistics

Newcastle University

February 2016

Abstract

This thesis examines the syntactic structure of clauses in Central Kurdish, focusing specifically on the syntax of verbs and verbal categories including tense, aspect, agreement, argument structure and their interplay with various verb types. It thus provides the first account to a number of syntactic phenomena in the language, which has not been subject to much detailed investigation before.

In analysing the phrase structure for the language, a number of proposals concerning the derivation of affixes are reviewed. Within the current theory of syntax, suffixation of morphemes to lexical heads is derived via head movement, considering strict locality and the Linear Correspondence Axiom (Kayne 1994), while prefixation is not derived by movement. Although such theory has a strong support from typological investigation (Julien 2002), it does not account for a language which has both prefixation and suffixation. Central Kurdish thus poses a serious challenge since inflected verbs are formed via both suffixation and prefixation. It is argued, however, that the difference in morpho-phonological properties between prefixes and suffixes brings about the difference in their method of derivation. This in turn accounts for much of the derivation of basic clause structure in the language.

A distinguishing characteristic of the syntax of Central Kurdish is related to its agreement pattern. The thesis argues that the tense-based split ergativity in the language is best accounted for by a theory in which case can be assigned by agreement. Although there is no morphological realization of case in Central Kurdish, the agreement-driven approach adopted in this study accounts for the agreement morphemes and the pronominal clitics found within the verbal complex of the language. The difference in the nature of ‘present’ and ‘past’ verb stems is responsible for the difference in the clausal structure of past and present tense, which is clearly reflected in the crossed agreement (split-ergative) pattern.

This study also accounts for the syntax of complex predicates in Central Kurdish in which light verbs are highly productive in their formulation. Any syntactic account of verbal inflections and agreement pattern is thus not complete if it cannot be applied to these complex predicates. It is shown that the composite of light verb plus the non-verbal element is responsible for the argument structure of the whole predicate. The analysis of the non-verbal elements, which have special characteristics, confirms the analysis proposed throughout the study, especially with regard to the account suggested for the split-ergative agreement of the language.

Declaration and Statement of Copyright

Declaration

No part of the material contained within this thesis has previously been submitted for a degree at Newcastle University or any other university.

Statement of Copyright

The copyright of this thesis rests with the author. No quotation should be published from it without his prior written consent and information derived from it should be acknowledged.

Acknowledgments

I would like first and foremost to express my gratitude to my supervisors, Professor Anders Holmberg and Dr Joel Wallenberg, for their support, guidance, and invaluable comments and feedback throughout writing this thesis. Special thanks to Professor Anders Holmberg who has always been available to meet with me to discuss the different parts of this work.

Second, I am grateful to the teaching and administrative staff at the School English Literature, Language & Linguistics (SELLL) and the Centre for Research in Linguistics and Language Sciences (CRiLLS), whose invaluable instruction has developed my knowledge in linguistics and contributed to the development of my academic skills.

Third, I am thankful for the scholarship awarded to me by the Ministry of Higher Education, Kurdistan Regional Government. Without their grant, my PhD study would not be possible.

Fourth, I am grateful to all my friends and colleagues at Newcastle University. They have all been a source of motivation, inspiration, and friendship.

Finally, my profound thanks go to all members of my family who have provided me with help and moral support.

List of Abbreviations

Abbreviations used in morphemic glossing

1	First Person
2	Second Person
3	Third Person
*	Ungrammatical
ABS	Absolutive
ACC	Accusative
AOR	Aorist
ASP	Aspect
CL	Clitic
CONJ	Conjunction
COP	Copula
DAT	Dative
DEC	Declarative Sentence Ending
DEF	Definite Marker
DEM	Demonstrative
DOM	Direct Object Marking
EVID	Evidential
EZ	Ezafe Marker
F	Feminine
IMP	Imperative
IND	Indicative
INDEF	Indefinite Marker
INESS	Inessive
IRR	Irrealis
NEG	Negation
NOM	Nominative
NOML	Nominal
OBJ	Object
OBL	Oblique
PART	Participle
PASS	Passive

PERF	Perfect
PL	Plural
POSS	Possessive
PREV	Preverbal Particle
PRS	Present Tense
PST	Past Tense
SG	Singular
SUB	Subjunctive
SUBJ	Subject
TOP	Topic

Other symbols used in glosses

=	clitic boundary (used to indicate pronominal clitics)
-	separates segmentable morphemes
∅	non-overt morpheme
.	separates metalanguage elements of a single segmentable morpheme
:	links the functional explanation of a given form

Abbreviations and symbols used in the text

ACC	Accusative
Adj	Adjective
Adv	Adverb
AGR	Agreement
AgrO	Object Agreement
AgrS	Subject Agreement
AgrSP	Subject Agreement Phrase
Arg	Argument of the verb
Asp	Aspect
AspP	Aspect Phrase
Aux	Auxiliary
AuxP	Auxiliary Phrase
CP	Complementizer Phrase
DP	Determiner Phrase
EPP	Extended Projection Principle

EvidP	Evidential Phrase
F	Functional head
FinP	Finite Phrase
FocP	Focus Phrase
Infl	Inflection
IP	Inflectional Phrase
LCA	Linear Correspondence Axiom
LV	Light Verb
MoodP	Mood Phrase
N	Noun
NegP	Negation Phrase
NPI	Negative Polarity Items
NV	Non-Verbal Element
OV	Object Verb
OSV	Object Subject Verb
P	Preposition
PF	Phonological Form
PIC	Phase Impenetrability Condition
PP	Prepositional Phrase
SOV	Subject Object Verb
Spec	Specifier
SubjP	Subject Phrase
SVO	Subject Verb Object
T	Tense
TAM	Tense Aspect Mood
TopP	Topic Phrase
TP	Tense Phrase
UG	Universal Grammar
V	Verb
VO	Verb Object
VoiceP	Voice Phrase
VP	Verb Phrase
vP	Light Verb Phrase

Table of Contents

Abstract	I
Declaration and Statement of Copyright	II
Acknowledgments	III
List of Abbreviations	V
Table of Contents	VIII
List of Tables and Figures	XI
Chapter 1. Introduction	1
1.1 Theoretical Framework.....	1
1.2 Goals and Significance of the Study.....	4
1.3 Language and dialect under study	6
1.4 Previous Works on Central Kurdish.....	8
1.5 Organization of the Thesis.....	9
Chapter 2. Verbal Morphology in Central Kurdish	11
2.1 Introduction.....	11
2.2 The Verb System in Central Kurdish	11
2.2.1 Verb Roots	11
2.2.2 Verb Stems.....	13
2.3 Types of Verb in Central Kurdish	17
2.4 Prefixal Morphology.....	20
2.4.1 The Negation Particle	21
2.4.2 The Mood Markers	24
2.4.2.1 The Indicative Marker	24
2.4.2.2 Subjunctive and Imperative Markers.....	25
2.5 Suffixal Morphology	28
2.5.1 Tense.....	28
2.5.2 Aspect	29
2.5.3 Passive	31
2.5.4 Agreement Markers	32
2.6 Verb Forms with Tense-Aspect-Mood	35
2.6.1 Present Stem Verb Forms	35
2.6.1.1 Present Indicative.....	35
2.6.1.2 Present Subjunctive	35
2.6.1.3 Imperative and Prohibitive	37
2.6.2 Past Stem Verb Forms	38
2.6.2.1 Past Perfective	38
2.6.2.2 Past Imperfective	39
2.6.2.3 Present Perfect	40

2.6.2.4	Past Perfect	41
2.6.2.5	Past Subjunctive.....	43
2.7	Summary.....	46
Chapter 3. The Structure of TP in Central Kurdish		48
3.1	Introduction.....	48
3.2	Inflectional Morphology and Syntax	49
3.2.1	Head Movement.....	50
3.2.2	Phrasal Movement	57
3.3	Prefixation vs Suffixation	63
3.4	Deriving the Verbal Complex in Central Kurdish.....	67
3.5	The Split TP.....	70
3.5.1	Negation Projection	72
3.5.2	TP Projection	74
3.5.3	Aspect Projection.....	77
3.5.4	Passive Projection	79
3.6	Argument Positions	81
3.7	Recalcitrant Residues.....	87
3.8	Summary.....	88
Chapter 4. Agreement Marking.....		90
4.1	Introduction.....	90
4.2	Split-Ergativity	91
4.3	Agreement in Central Kurdish.....	94
4.3.1	Nominative-Accusative Alignment	97
4.3.2	Ergative Alignment.....	99
4.3.3	Clitic Placement.....	101
4.3.4	Clitic-Affix Concatenation	104
4.4	Agreement in Minimalism.....	106
4.5	Past vs Present	111
4.6	The Syntax of Agreement in Central Kurdish	118
4.7	The Status of the Pronominal Clitics	127
4.8	Other Ergative-like Constructions	129
4.8.1	Applicative Constructions.....	129
4.8.2	The Passive Ditransitive	132
4.8.3	The Possessive Construction	136
4.8.4	The Want Construction.....	139
4.9	Summary.....	142
Chapter 5. Complex Predicates		143
5.1	Introduction.....	143
5.2	General Characteristics of Complex Predicates	143
5.3	Complex Predicates in Central Kurdish	147
5.4	The Components of Complex Predicates	151

5.4.1	Light verbs vs Heavy verbs	151
5.4.2	Non-Verbal Elements	155
5.4.2.1	Preverbal Particles	155
5.4.2.2	Nominals.....	157
5.5	The Syntax of Complex Predicates in Central Kurdish.....	162
5.5.1	LVs and little v	162
5.5.2	NV elements and Complex Predicate Structure	166
5.5.2.1	Nominal NVs.....	167
5.5.2.2	Non-Nominal NVs.....	176
5.6	Verbal Inflections and Complex Predicates	182
5.6.1	Prefixal Morphology in Complex Predicates.....	182
5.6.2	Suffixal Morphology in Complex Predicates	184
5.6.3	Agreement Pattern in Complex Predicates	186
5.7	Summary.....	189
	Chapter 6. Conclusions.....	191
	List of References	195

List of Tables and Figures

Figure 1.1: Kurdish language speaking area.....	7
Table 2.1: Independent and bound pronominals in Central Kurdish.....	32
Table 5.1: Some preverbal particles used with light verbs in Central Kurdish	149

Chapter 1. Introduction

1.1 Theoretical Framework

There is a central distinction between two types of syntactic categories, ‘substantive’ and ‘functional’, and this distinction plays a crucial role in the theory of generative grammar. Almost all items of the lexicon belong to the substantive categories, such as nouns, verbs, and adjectives which all have lexical meanings. The functional categories are grammatical categories which have only functions in a sentence. They are of limited number and include among others tense, complementizers, aspect, (Chomsky 1995: 6). The distinction between substantive and functional categories is not something new. Grammarians have long divided words on the basis of whether they have ‘referential meaning’ or ‘grammatical function’. In all the languages of the world this distinction exists. For example, in English words such as ‘*syntax*’ and ‘*beautiful*’ have lexical meanings and thus belong to substantive categories; while ‘*the*’ and ‘*-ing*’ carry the grammatical content of a sentence and might not have a lexical meaning. As Borer (1984) and Ouhalla (1991) propose, only functional categories can display syntactic variation. In other words, functional elements can be considered to be the locus of all syntactic variation, whereas substantive categories have, to a large extent, similar properties across different languages.

Depending on specific languages, functional categories are realized differently. While in some languages (English, for example) a functional category such as negation can be realized by a word, other languages (such as Kurdish) might use inflectional morphology like an affix for this purpose. Whether they are independent words or affixed to other words, since they perform grammatical functions, functional categories including inflectional morphemes should thus obey syntactic principles and constraints and can thus be considered as the spell out of syntactic heads, which head functional projections (Chomsky 1995, Pollock 1989, Baker 1988). In other words, it is a theoretical claim that functional categories, even when they are affixes, are heads of phrases.

A question that can be raised at this point is: what constrains the functional (i.e. non-lexical) projections? One possible constraint might be that functional projections correspond to inflectional categories. As is the case, the number of functional projections is different from one language to another, and it seems to depend on the inflectional

morphology of the language. This is not uncontroversial, however. Some claim that they are exactly the same in all languages, the variation is which of them are spelled out (Cinque 1999; Sigurdsson 2011). Still, assuming all inflectional morphemes of a language should correspond to functional projections is wrong. In fact, only those inflectional morphemes which correspond to functional categories in a given language can syntactically be heads of maximal projections.

Inflectional morphemes or affixes such as agreement, aspect, tense, negation markers that are included within verbal construction are often considered functional heads (Ouhalla, 1991; Belletti 1990, 1994). If such heads are used to realize grammatical functions such as tense or aspect and are closely attached to the verb stem, how can they be included within the verbal structure? Following Chomsky (1989) and Pollock (1989)'s 'Split Inflection' Hypothesis each inflectional element (tense, agreement, negative, aspect, etc.) can head its own projection and be in a head-complement relation with another phrasal category, forming hierarchic structures such as [_{NegP} Neg [_{TP} T [_{AspP} Asp ...]]].

Verb stems in Central Kurdish cannot stand on their own as a predicator; they have to be accompanied by a number of inflectional bound elements such as agreement markers, mood markers, or aspect morpheme. Such inflectional expressions can take the form of affixes added to the verb stem, which forms the integral and minimal part of the VP. Verbs seem to always be inflected for tense; that is, they are either present or past tense when used in a sentence. They can also be inflected for aspect, mood, negation, person and number and show distinctions of transitivity and voice. This, however, should not be taken to mean that the language does not have infinitives. Following Baker's (1985) 'Mirror Principle', which states that morphological derivations must directly reflect syntactic derivations, verbal inflectional morphemes in Central Kurdish can each correspond to a functional category and can thus be syntactically the head of a maximal projection.

There are a number of theories dealing with the interface between morphology and syntax. Although it is not within the scope of this thesis to compare these theories, it is significant to state which approach has been taken. The non-lexicalist architecture is adopted by many approaches to complex word-formation, and is mostly adopted in this study. In such an approach, words and phrases are identically constructed by the syntactic component. This means there is no distinct word-formation module in the language

component. The internal structure of (complex) words follows the same syntactic operations and semantic interpretation as the external structure of words does. Thus, it is the morphemes, not phonological words, that correspond to syntactic terminal nodes.

Most non-lexicalist approaches adopt a generally Minimalist view of the structure-building component (Chomsky 1995, 2000, 2001a). Nevertheless, they can significantly be different from each other in terms of the nature and number of mechanisms they employ to create the complex structures that will end up being realized as phonological word-sized elements. In these approaches, the rigid ordering and selectional requirements of morphemes are not related to differences between the operations available in different components of the grammar, but rather have some other source. Particularly, all structures are created by the single operation of *Merge*. In this study, a kind of non-lexicalist approach is adopted in which there is no non-syntactic operation and morpheme orders are derived in a way that respects Kayne's Antisymmetry Theory (Kayne 1994). Accordingly, the asymmetric c-command relationship maps onto the linear order of the morphemes. In other words, in the sense of Julien (2002), the actual order of morphemes is not attributed to the properties of individual morphemes (affixes). Instead, the surface order of morphemes is a direct consequence of syntax.

As will be explained in detail in chapter three, the two syntactic operations of head movement and phrasal (remnant) movement are typically responsible for the derivation of morpheme order. For example, it is generally assumed that the formation of a verb with a tense suffix in a number of languages of the world involves the leftward movement and left-adjunction of V^0 to T^0 . In this respect, the morpheme sequence of $[V^0-T^0]$ will be formed, not a $[T^0-V^0]$ order, as the antisymmetry requirement forces all head-movement to be leftward and left-adjoining. Complex words which seemingly involve rightward movement or suffixation of a lower to a higher constituent are derived through phrasal remnant movement, rather than head movement.

What remains to be stated here is that the Distributed Morphology framework of Halle and Marantz (1993) and subsequent works, which involves a number of additional post-syntactic operations, is not adopted in this study. This is because almost all the verbal inflections of the language can be derived through well-motivated syntactic operations, without appealing to post-syntactic operations. In other words, a non-lexicalist approach is adopted in this study that does not involve any non-syntactic operations.

1.2 Goals and Significance of the Study

To begin with, characterization and identification of the various verbal inflections of the language is key for their syntactic analysis proposed throughout this study. Within the few studies on the language, the identification of the various verbal affixes has often been carried out incorrectly. For instance, it is often claimed that Central Kurdish has as many as seven suffixes (Fattah 1997). As will be argued in subsequent chapters, this claim is not correct. Hence, it is the first goal of this study to identify the number and type of the many verbal inflections in the language.

Aside from a descriptive account of most verbal aspects of the language, the present study attempts to discuss and theoretically account for a number of syntactic issues. Inflectional expressions in Central Kurdish, which convey various semantic elements, can combine in a single morpho-phonological unit. These inflectional expressions can take the form of affixes added to the verb stem. That is, verbal morphology in Central Kurdish is characterized by various bound prefixes and suffixes added to the verb stem. If these verbal affixes correspond to functional heads, how is it possible to derive the verbal complex in the language?

It is widely assumed (e.g. Baker 1985, 1988) that complex words are the result of head movement in the syntax. If this syntactic process always results in left-adjunction of the moved head to the next higher head, as in Kayne's (1994) antisymmetry theory, then head movement can only create complex words with suffixes. If so, head movement cannot exhaustively account for the formation of complex verb in Central Kurdish because if the verb head moves to attach to its inflectional markers, one should expect to find only suffixes in the language. This is obviously not the case as there are prefixes and suffixes attached to the verb stem. Accordingly, head-movement cannot be the only way of concatenating morphemes to form inflected words. As Julien (2002) argues, prefixation should not be derived through head-movement. Instead, prefixation can be derived in two possible ways. The first way is that the prefix originates in the complement position of the lexical element and then via either head movement or XP (phrasal) movement moves to the left of the lexical element. The other way is that the prefix originates to the left of, and c-commanding, the lexical element, and attaches to it in PF without movement of any of the two elements.

Yet another method of deriving complex words, especially in SOV languages, is via phrasal movement (Kayne 1994, Holmberg 2000, Julien 2002). Julien (2002) also argues that verb final languages are consistently head-final as far as their Tense Phrase (TP) is concerned. Then, if this is the case, the surface order is derived by moving the complement of every functional head to the specifier of its phrasal projection, also known as ‘roll-up’ movement.

It is the case, then, that there are different ways of deriving complex words in different languages. Since Central Kurdish contains both verbal prefixes and suffixes, and is an SOV language, it presents an interesting case study. This thesis will investigate which syntactic processes are responsible for the derivation of verbal complexes in the language, and why different types of affixation are required within the verbal inflection of Central Kurdish.

Agreement is another significant and integral part of verbal inflection in Central Kurdish. Different from other functional heads that have interpretable features, agreement features are generally uninterpretable and parasitic on other heads. In other words, agreement does not occupy a specific functional head within the TP structure, as widely assumed within today’s syntactic theory (e.g. Chomsky 2001a). As Central Kurdish has split-ergativity, its syntax presents an intriguing phenomenon in that present and past tense clauses have somewhat different structure. There are two sets of agreement markers, of which one set is affixes and the other is clitics. Such bound morphemes seem to exchange their function (subject and object agreement) depending on the tense and transitivity of the clause. Thus, accounting for the syntax of agreement is crucial for the understanding of a number of syntactic issues within the clausal structure of the language.

While achieving the above goals can principally account for the syntax of a simple predicate in Central Kurdish, it remains to be seen how the syntax of verbal inflectional morphemes and the basic TP structure of the language can be applied to a complex predicate. Central Kurdish is a language that depends extensively on light verbs such as *kirdin* ‘to do’ plus non-verbal elements like nouns or adjectives to create new lexical verbs. Such complex predicates (also called light verb constructions) have a number of remarkable characteristics. Accounting for the syntax of light verbs and the non-verbal constituent of such complex predicates is another goal of this study.

1.3 Language and dialect under study

Kurdish is the language of around 30-40 million people. The Kurds mainly inhabit Kurdistan, which has been divided among the four countries of Iraq, Iran, Turkey, and Syria after the First World War. They also live in some other countries such as Armenia, and there is a large Kurdish diaspora in Europe and the United States. As shown in the figure 1.1 below (taken from Öpengin 2013: 2) , Kurdish is widely spoken over an area that spreads from the south west of Hamedan (Iran) to the southern tip of Lake Urmia, along its western shore and to the junction of the Persian, Armenian and Turkish borders. From the Turkish-Armenian border, the Kurdish-speaking area continues westward until it reaches the Euphrates River before turning south to the Syrian border. Thus, the area also encompasses the north-east of Syria close the Turkish border. On entering Iraq, it covers the north of Mosul and continues to the south-east to the border with Iran near the Khanaqin, whence reaching Ilam and the south of Kermanshah.

Following Haig and Öpengin (2014), Kurdish can be divided into five groups or dialects¹, which are Northern Kurdish (also known as Kurmanji), Central Kurdish (also known as Sorani Kurdish), Southern Kurdish, Gorani (also known as Hawrami), and Zazaki. The boundaries of these groups are shown in figure 1.1.

Each of these dialects contains subdialects or varieties. Northern Kurdish may include Hakkari, Botani, Bahdinani, Muş, Adiyaman, etc. Central Kurdish subsumes Sulaimani, Mukri, Ardelani, and Garmiani. Southern Kurdish comprises Kelhuri, Feyli, Laki, and Kirmashani. Gorani includes the varieties of Paveh, Hawramani of Halabja, and Bajalani. Zazaki can be divided into three main subdialects of Northern, Central, and Southern Zazaki. It is worthy of note that many researchers believe that Gorani (Hawrami) and Zazaki are sub-groups or related varieties of Central Kurdish and Northern Kurdish, respectively.

¹ Other researchers (e.g. Fattah 1997, Nabaz 1976) divide the Kurdish dialects differently. Since this is not a study on dialectology, this issue is not pursued any further.

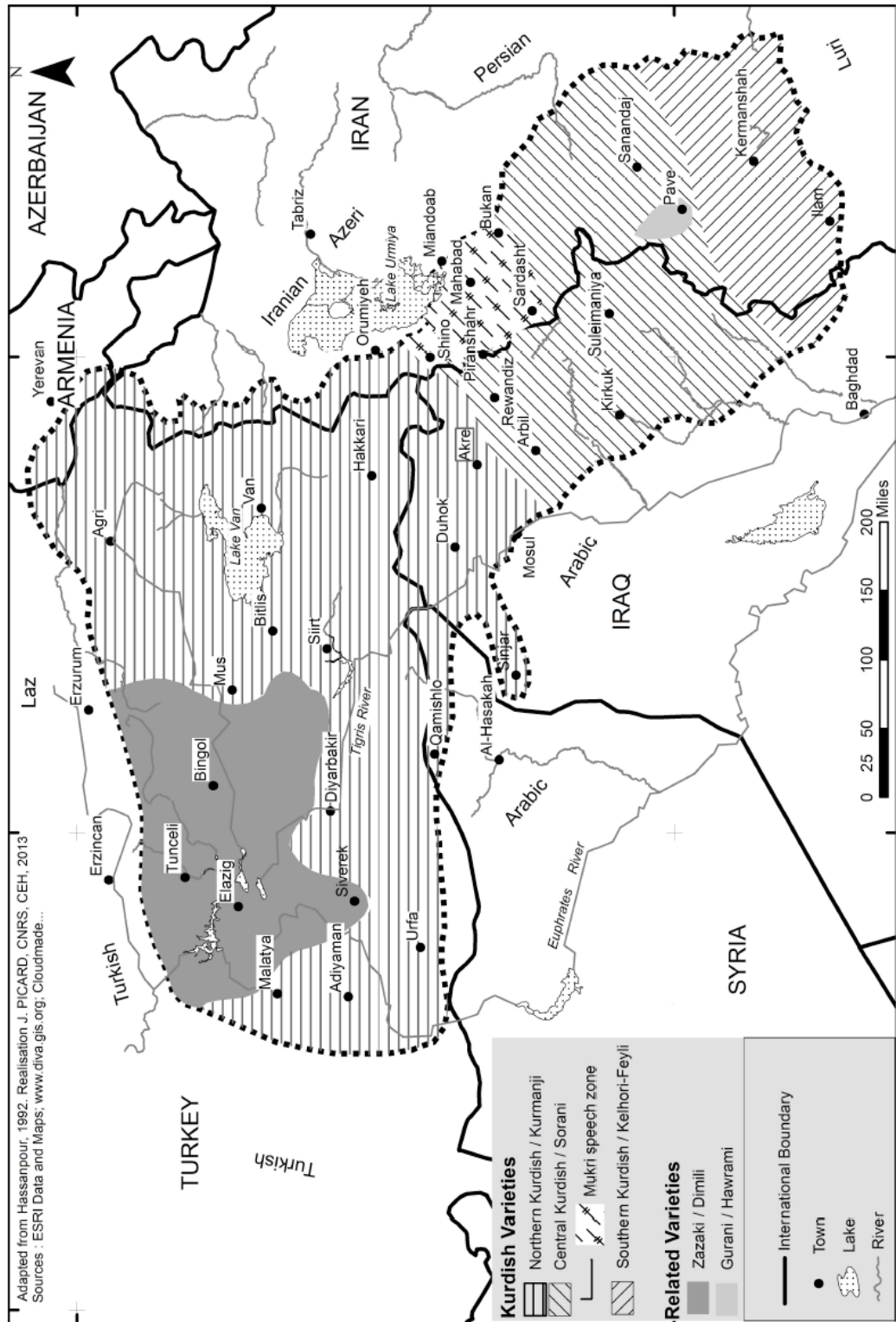

Figure 1.1: Kurdish language speaking area (taken from Öpengin 2013: 2)

The dialect under study is what is generally referred to as the standard Central Kurdish. It is the standard language of journalism, official and private correspondence and informal speech. It is also the official language of education and administration in the Kurdistan Region of Iraq. The pronunciation and variety is typically of Sulaimani, which the standard of Central Kurdish is largely based on. It is also the native language of the present researcher. The exact number of its speakers is not known, but Lewis *et al.* [Ethnologue] (2014) estimates its population as 6,750,000 speakers.

1.4 Previous Works on Central Kurdish

There have been a number of studies on Central Kurdish by both orientalist and native scholars. The majority of these studies are on the two varieties of Mukri and Sulaimani, which are very close to each other. Most of the early studies are impressionistic grammar sketches (e.g. Edwards 1851, Chodzko 1857) or wordlists (e.g. Houtum-Schindler 1884) or dialectological surveys (e.g. De Morgan 1904, Mann 1906). An early comprehensive grammar sketch and description of Kurdish, focusing specifically on both Central and Northern Kurdish, comes from E. B. Soane (1913), whose years of study and residence among the Kurds of various parts of Kurdistan had enabled the author to accomplish this. Fossum (1919) is another structured grammar of Kurdish, although it is not clear which variety of Central Kurdish his grammar is based on. Both Soane (1913) and Fossum (1919) are traditional descriptive studies on the language.

As Öpengin (2013) states, MacKenzie (1961) is perhaps one of the most important works in the history of Kurdish dialectology and linguistics. It is a comparative work on the different varieties of Central Kurdish spoken in Iraq. It should be noted, though, that little attention has been given to the syntax of the language. In contrast to this, McCarus (1958, 2009) is another concise but rather complete grammatical sketch of Sulaimani Central Kurdish. Thackston (2006) is also a brief and practical account of Sulaimani Central Kurdish. It is actually more practical to those who know the language than a linguist who is not familiar with the language. This is because no glosses are provided throughout the work and no specific approach in analysing the grammar is given. Many other works have been done by native scholars. Since these scholars do not have command of English, their work is largely descriptive and their background knowledge is usually not up-to-date with the current trends of linguistics.

In terms of theoretical approaches, almost none of the above-mentioned studies relate their various descriptive components to a coherent theoretical framework. However, within the generative framework, there have been a number of studies recently. Fattah (1997) is possibly the first work on Central Kurdish carried out within the framework of Government and Binding Theory. Although a detailed work on different aspects of the language such as its phonology, morphology, and syntax, it does not provide an accurate syntactic analysis of most aspects of the verbal inflections and agreement pattern, and many of his conceptions that are referred to throughout this thesis are challenged. Yadgar Karimi has written a number of papers on the Ezafe construction (2007) and agreement (2010, 2013). Karimi-Doostan (2005) discusses some aspects of complex predicates. Within other frameworks, Samvelian (2006, 2007) uses the framework of Head-Driven Phrase Structure Grammar (HPSG) to discuss clitics in Central Kurdish. An extensive but descriptive account of the agreement pattern, specifically the clitic-affix interactions, of the language within prosodic phonology, is provided in Öpengin (2013). It is important to note that Öpengin's study also provides a grammatical sketch of Central Kurdish, based particularly on the Mukri variety. A number of works by Geoffrey Haig (e.g. Haig 2004, 2008) on the alignment pattern of the language are carried out in a rather theory-neutral framework. Öpengin (2012)'s paper on adpositions and argument structure in Central Kurdish also adopts a theory-neutral approach. It is worth mentioning here that almost all these works, where relevant, are referred to and discussed in this thesis.

1.5 Organization of the Thesis

The rest of this thesis is organized in the following way. In chapter two, descriptive background on the various inflectional affixes within the verbal complex is provided. The chapter also presents a general grammatical sketch of the language. Most importantly, it attempts to rectify a number of wrong assumptions concerning the number and status of the various verbal affixes. The correct identification and characterization of the various verbal affixes, in turn, will be helpful in the analyses presented in the subsequent chapters. Chapter three discusses the basic clausal structure of the language. To account for the basic TP and argument structure of the language, a number of proposals with regard to prefixation and suffixation are reviewed. It is shown that the various verbal affixes represent functional categories heading syntactic projections. In particular, it is argued that the difference in morpho-phonological properties between prefixes and suffixes

results in a difference in their method of derivation. This in turn accounts for many aspects of the derivation of basic clause structure in the language. The positions of the verbal arguments are briefly discussed as well.

As stated in section 1.2, an important aspect of verbal inflection is related to the agreement patterns of the language, which are discussed in detail in chapter four. This involves consideration of the syntax of agreement morphemes and the status of pronominal clitics. It is demonstrated how current Minimalist theory can account for the phenomenon of split-ergativity in Central Kurdish as well as some other Kurdish dialects. Chapter five deals with complex predicates in the language. It shows how the analysis proposed for simple predicates throughout the thesis applies to complex predicates. As light verbs are an integral part of the syntax of the language and participate largely in the formation of new lexical verbs, it is necessary to discuss the syntax of such predicates, focusing specifically on the status of the verbal inflections and non-verbal elements that constitute such a construction. The final chapter provides a number of conclusions to this thesis.

Chapter 2. Verbal Morphology in Central Kurdish

2.1 Introduction

Within traditional and descriptive literature on Central Kurdish, the various verbal prefixes and suffixes are characterized incorrectly. In this chapter, the verbal morphology of the language is characterized and described. In particular, the various inflectional morphemes are identified. The identification and description of each verbal inflection is essential because it lays the foundation for their syntactic analysis in the chapters that follow. Without their proper identification, it is difficult, if not impossible, to account for the syntax of verbal inflections in the language.

The chapter is organized as follows. In the next section, which is about the verb system in Central Kurdish, I describe verb roots and establish how they are different from verb stems. In addition, I discuss the so-called ‘present’ and ‘past’ stems in the language and argue that such stems do not contain a tense feature or morpheme. In section 2.3, I divide verbs in the language into two main types: thematic verbs and light verbs. The focus of this chapter and the next two is mainly on simple thematic verbs rather than light verbs, which will be dealt with in chapter five. Also, in this section, I establish the basic word order of Central Kurdish plus the bound affixes within the verbal complex. Section 2.4 identifies and characterizes the prefixal morphology, which contains the negative particles and the mood morphemes. Section 2.5 deals with the suffixal morphology. In contrast to almost all scholars on Central Kurdish, I maintain that the language does not contain as many as seven suffixes. Rather, its verbal morphology contains only three suffixes, which are aspectual morphemes, passive suffixes, and agreement markers. After establishing the basic verbal morphology, in section 2.6, I deal with the various verb forms used in the language. Having a proper analysis of these forms will be helpful and necessary in dealing with many aspects of verbal syntax in the language.

2.2 The Verb System in Central Kurdish

2.2.1 *Verb Roots*

Like other major syntactic categories, verbs are made up of roots, bases, stems, derivational affixes, inflectional affixes, and sometimes clitics. The root is the smallest

lexical unit upon which a word is formed; that is, a root is that part of a word from which all affixes and other grammatical morphemes have been removed, leaving only one morpheme, the root. As Katamba (1993: 20) puts it, ‘morphemes cannot be decomposed into smaller units which are either meaningful by themselves or mark a grammatical function.’ Thus, the root is ‘the unreducible core of a word, with absolutely nothing else attached to it’ (ibid).

In contrast to free morphemes, which can stand alone by themselves, the roots of verbs in Central Kurdish are bound morphemes. They require some inflections in order to form the verb stem. They thus cannot be considered independent morphemes, corresponding to, for example, verbs in English such as *go* or *eat*, which occur without any (overt) inflection in various contexts. Thus, English verbs in a sentence can describe a situation without the help of (overt) inflections while this is not possible in Central Kurdish as verb roots are bound morphemes.

As Amin (2004) explains, although the core meaning of the verb is expressed by the verb root, the meaning of the lexical verb is not conveyed by the verb root only but via the verb root plus the inflections attached to it. For instance, the root *-rro-* is not a word in Central Kurdish but a bound morpheme. If no further inflections are added to it, no speaker would recognize it. Thus, when the indicative marker *de-* is prefixed to the verb root and when the subject agreement marker *-m* is suffixed to it, a string *de-rro-m* ‘I go’ is formed, which conveys the meaning of the essential part of the verbal construction, namely, *-rro-*.

It is significant to distinguish between root and stem. A root does not necessarily have a lexical meaning and its semantic range can be vague if there is any at all (for instance *cran* in *cranberry*). On the other hand, a stem is partially different from a root in that it must have lexical meaning. A stem may also contain derivational affixes. Being the smallest lexical unit, which is common to a verb, a noun, and an adjective, the root is usually, or even always, a category-neutral lexical element. Marantz (1997) proposes that lexical elements are category-neutral, their category being determined by the functional material with which they are associated. The stem is the result of combining the root with a category-forming head. This view is widely adopted in current generative theory. It still remains controversial whether all roots are category-neutral, though (see Baker 2003: 280-282; Panagiotidis 2014). I remain agnostic regarding this issue. I will not represent

the category-forming functional head in my structural descriptions except when directly relevant for the issue discussed.

As shown in the following, it is often difficult to distinguish between verb root and verb stem (especially the present stem) in Central Kurdish. This, however, has no ramification with regard to the characterization and analysis of the various verbal inflections throughout this thesis.

Infinitive Form	Past Stem	Present Stem	Verb Root
kêşan ‘to weigh’	kêşa-	-kêş-	kêş
birrîn ‘to cut’	birrî-	-birr-	birr
çûn ‘to go’	çû-	-ç-	ç
mirdin ‘to die’	mird-	-mir-	mir
hatin ‘to come’	hat-	-(h)e-	?

2.2.2 Verb Stems

Although verbs in Central Kurdish are almost always inflected for tense, they have a non-finite form, namely the infinitive, consistently marked by the suffixed infinitive marker – *(î)n*. It is thus not the case that forms of verbs in the language are derived from the infinitive, as is traditionally thought. Like verb stems, the infinitival form of verbs can be either simple (e.g. *birrîn* ‘to cut’), which form the basis for thematic verbs, or complex (e.g. *ser birrîn* ‘to behead’), which form the basis for complex predicates (or light verb constructions).

All verbs, thematic or light, can be divided into two groups according to the stem they use in their formation: those that use the so-called present stem and those that can be formed on the so-called past stem. Katamba (1993: 45) defines the stem as ‘that part of a word that is in existence before any inflectional affixes have been added.’ In particular, a stem is the result of a root plus a category-forming head. Hence, to divide verb stems in Central Kurdish according to whether they are present or past, as done in most literature on the language, seems problematic. This is because a stem, being formed by combining a root with a category-forming head, is not yet marked for tense. However, I believe that using the notions ‘past’ and ‘present’ stems, as is traditional in work on Kurdish and

related languages, is only to indicate that a certain stem is associated with a certain tense, not that it actually encodes tense.

Throughout this thesis, I use the terms ‘past’ and ‘present’ stems only to refer to the fact that a certain stem is associated with a certain tense without the stem containing any tense feature. Julien (2002) also assumes Persian present and past verb stems do not contain tense features. Notably, each of the present or past verb stems in Central Kurdish can have other uses where the tense associated with it would be irrelevant. For instance, past verb stems can be used to express future tense, as in the subordinate clause of (1), while the present stem is required with the imperative or subjunctive mood, which are represented by the prefixed marker *bi-*, as in (2) and (3) respectively.

(1)

ke	roîşt-n,	telefûn	de-ke-m.
that	leave.PST-3PL	telephone	IND-do.PRS-1SG

‘When they leave, I will call.’

(2)

bi-rro!
IMP-go.PRS
‘Go!’

(3)

pêwîst-e	bi-xwên-m.
necessary-be.PRS.3SG	SUB-study.PRS-1SG

‘It is necessary that I study.’

In the formation of the passive, only the present verb stem is used with both tenses. The passive morphemes (*-rê* for present and *-ra* for past) are added to the present verb stem, as shown in (4a) and (4b) respectively.

(4)

a. de-kuj-rê-m.
IND-kill.PRS-PASS.PRS-1SG
‘I will be killed.’

- b. kuj-ra-n.
 kill.PRS-PASS.PST-3PL
 ‘They were killed.’

Therefore, while the only indication of the tense of any given verb in Central Kurdish is actually the form of the stem itself, it appears that the stem does not directly spell out the tense morpheme (see also section 2.5.1). Instead, the choice of either the past or present stem depends on the tense of the clause or mood morphemes that are present in the verbal complex, without the stem forms actually spelling out tense.

Past stems are easily derivable from the infinitival form of the verb simply by deleting the suffixed infinitive marker $-(\hat{i})n$. Again, the derivation of the past verb stem from the infinitival form of the verb indicates that the past stem should obviously not contain tense. We do not want to derive a tensed stem by deleting the infinitive marker from an infinitive form which has no tense itself. Hence, the use of the term past stem is mainly to indicate that this stem is used for past tense constructions.

As Fattah (1997) elucidates, depending on the last segment that remains after the deletion of the infinitive marker, five groups of past stems in Central Kurdish can be formed, as exemplified in the following.

Group 1 (ending in $-\hat{i}$)

<u>Infinitive Form</u>	<u>Past Stem</u>
firrî ‘to fly’	firrî ‘flew’
kirrî ‘to buy’	kirrî ‘bought’

Group 2 (ending in $-\hat{u}$)

<u>Infinitive Form</u>	<u>Past Stem</u>
bûn ‘to be’	bû ‘was’
dirûn ‘to sew’	dirû ‘sewed’

Group 3 (ending in $-a$)

<u>Infinitive Form</u>	<u>Past Stem</u>
hênan ‘to bring’	hêna ‘brought’
kêşan ‘to weigh’	kêşa ‘weighed’

Group 4 (ending in *-d*)

Infinitive Form

nardin ‘to send’

xwêndin ‘to read’

Past Stem

nard ‘sent’

xwênd ‘read’

Group 5 (ending in *-t*)

Infinitive Form

kewtin ‘to fall’

hatin ‘to come’

Past Stem

kewt ‘fell’

hat ‘came’

It seems that the derivation of present verb stem in Central Kurdish is from the past verb stem. Although some general rules regarding the derivation can be drawn, it is not normally predictable, as Fattah (1997) explains. Nonetheless, one general rule is that the present stem is derived from the past stem by dropping or deleting what looks like ‘past tense markers’ (*-d, -t, -a, -î, -û*), as shown in the following.

Infinitive Form

birrîn ‘to cut’

çûn ‘to go’

hênan ‘to bring’

mirdin ‘to die’

girtin ‘to catch’

Past Stem

birrî ‘cut’

çû ‘went’

hêna ‘brought’

mird ‘died’

girt ‘caught’

Present Stem

birr ‘cut’

ç ‘go’

hên ‘bring’

mir ‘die’

gir ‘catch’

However, it should be noted that there are exceptions to such a rule and sometimes phonological modification is necessary. One exception is related to Group 3 past stems that end with *-a*, especially those that are intransitive. Instead of dropping the past tense marker *-a*, the final vowel changes to *-ê*, as exemplified by the verb ‘to lose’ in the following. As Fattah (1997) notes, another unpredictability is related to the monosyllabic infinitives of this group of infinitives, as shown in the examples of ‘to give’ and ‘to remain’ in the following.

Infinitive Form

dorran ‘to lose’

dan ‘to give’

man ‘to remain’

Past Stem

dorra ‘lost’

da ‘gave’

ma ‘remained’

Present Stem

dorrê ‘lose’

dê ‘give’

mê ‘remain’

Another exception is related to Group 2 infinitives. Although the present stem can normally be derived from the past stem by deleting the past tense marker *-u*, this is not always the case. When the verb is transitive, present and past stems are identical, as shown in the following.

<u>Infinitive Form</u>	<u>Past Stem</u>	<u>Present Stem</u>
dirûn ‘to sew’	dirû ‘sewed’	dirû ‘sew’

With regard to Group 4 and Group 5, the derivation of present stem sometimes comprises some fundamental modification or deletion of vowels in addition to the deletion of what is traditionally considered past tense marker. In other words, the derivation can sometimes be very unpredictable, as shown in some examples of the following.

<u>Infinitive Form</u>	<u>Past Stem</u>	<u>Present Stem</u>
kirdin ‘to do’	kird ‘did’	ke ‘do’
birdin ‘to take’	bird ‘took’	be ‘take’
şitin ‘to wash’	şit ‘washed’	şo ‘wash’

To conclude this section, the use of the notions of present and past stems in Central Kurdish literature is problematic. These stems should not be taken to include a tense feature or inflection. Although most research on the language assumes that *-d*, *-t*, *-a*, *-î*, *-û* are past tense markers which are assumed to be overtly realized and suffixed to the verb stem, such an assumption should be rejected given the argument that verb stems should not contain tense. In addition, while past tense markers seem to be ‘overtly realized,’ there is no overt marker for present tense. Hence, I maintain that the inflected verb does not contain any overt tense inflection (see also sections 2.5.1 and 3.5.2).

2.3 Types of Verb in Central Kurdish

There is no agreement in the literature with regard to the syntactic types of verbs in Central Kurdish. While Zangana (1989) claims that there are three types of verbs in Central Kurdish (simple, complex, and compound), Fattah (1997) assumes that there are no simple verbs in the language, and that every verb minimally consists of two morphemes. In other words, Central Kurdish verbs are either complex or compound. Although I agree with Fattah (1989, 1997) that there are no simple verbs, and that verbs in the language can morphologically be divided into complex and compound verbs, it is

better to divide them syntactically. Thus, instead of using the terms ‘complex’ and ‘compound’, I believe that the inflectional system for Central Kurdish verbs consists of thematic/lexical verbs, which are used in forming simple predicates, and light verbs, which are used in forming complex predicates.

Unlike light verbs, thematic/lexical verbs in Central Kurdish are not semantically bleached or light. They are made up of a verb stem plus at least one bound morpheme. The bound morphemes are grammatical ones which tend to change the syntactic nature of the verb. The verbal inflections do not change the semantics of the verb stem and they only have grammatical functions. The bound morphemes in Central Kurdish include the prefixed indicative marker *de-*, as in (5a) and (5b), the verbal agreement suffixes, as in (5a), (5b), and (5c), and the pronominal enclitics, as in (5b) and (5c), among other verbal inflectional morphemes.

(5)

- a. *de-rro-m.*
IND-go.PRS-1SG
‘I am going.’
- b. *de=î şkên-im.*
IND=3SG.CL break.PRS-1SG
‘I (will) break it.’
- c. *xward=man-in.*
eat.PST=1PL.CL-3PL
‘We ate them.’

Light verbs are used in complex predicate constructions, which consist of an inflected light verb plus a non-verbal element, consisting of at least one free morpheme. Light verbs such as *kirdin* ‘to do’ and *dan* ‘to give’ are often used with nouns to form such complex verbal structures, as shown in (6). The non-verbal element is shown in boldface.

(6)

- a. *minał-eke-an **şerr** de-ke-n.*
child-DEF-PL fight IND-do.PRS-3PL
‘The children are quarrelling.’

- b. **belên** de-de-m.
 promise IND-give.PRS-1SG
 ‘I promise.’

An interesting feature of the verbal system in Central Kurdish is related to the difference in the syntax of past and present tense (cf. Haig 2004). This difference will play a major role in the determination of the overall verbal structure, the theta-marked position of the subject, and agreement patterns in the language (see chapter four). Inflected verbs in the present tense cannot come alone but are always preceded by the indicative marker *de-* and be followed by a subject agreement marker, which is a verbal agreement suffix in the present tense. There is no overt suffix on the verb stem indicating present tense, as can be noticed in (7).

- (7)
 min pîtza de-xo-m.
 I pizza IND-eat.PRS-1SG
 ‘I eat pizza / I am eating pizza.’

The inflected verb in the past tense seems to have a past tense marker as the past stem is used in their formation. However, as explained in the previous section, like in the present tense, I maintain that there is no overt past tense marker in the language (see also section 2.5.1 for more discussion on tense morphemes in Central Kurdish). Unlike inflected verbs in the present tense, which are always preceded by the indicative marker, this marker is rarely used in conjunction with inflected verbs in past tense. When used, it refers to a past progressive action. Besides, the subject agreement marker in the past transitive is a pronominal clitic instead of a verbal agreement suffix, as shown in (8).²

- (8)
 sêw-eke-an=im xward-Ø.
 apple-DEF-PL=1SG eat.PST-3SG
 ‘I ate the apples.’

The above examples also show that the surface (unmarked) word order in Central Kurdish is SOV. It is possible to have SVO order, though it is a marked order, as in (9).

² See chapter four for a discussion on the default third person object agreement in the past.

(9)

min de-xo-m pîtza.
I IND-eat.PRS-1SG pizza
'I am eating pizza. / I eat pizza.'

However, such flexibility with word order is not possible if both arguments (subject and object) are animate. This might be because the inanimate DP is more likely to be the object which gives it more freedom of ordering. If both arguments are animate, as in the examples of (10), only SOV order is possible. The sentence in (10b) does not sound natural or even grammatical since the animate object follows the verb. Thus, the basic (surface) OV order will be retained.

(10)

- a. Azad Karwan de-kuj-ê(t).
Azad Karwan IND-kill.PRS-3SG
'Azad kills/will kill Karwan.'
- b. *Azad de-kuj-ê(t) Karwan.

It is significant to note that when the object complement is a clause rather than a DP, the order is actually SVO, as demonstrated in (11) below.

(11)

wîst=im bi-rro-m.
want.PST=1SG.CL SUB-go.PRS-1SG
'I wanted to go.'

2.4 Prefixal Morphology

It is assumed in most literature on Central Kurdish (e.g. Fattah 1997) that the verb stem can be preceded by three prefixes, which are thought to be the preverbal particles, the negation particle, and the aspect marker, ordered as in the following:

Preverbal Particles > Negative Particle > Aspect Marker > Verb Stem

I maintain, however, that the assumption that the verb stem is preceded by three prefixes is incorrect. In the first place, the preverbal particles (see section 5.4.2.1 for a discussion

on these prepositional particles) should not be considered as verbal prefixes. The fact that they occupy preverbal position does not necessarily make them bound prefixes. As will be argued in chapter five, such preverbal particles behave similarly to non-verbal elements of complex predicates in Central Kurdish. Secondly, the indicative marker *de-* should not be considered an aspect marker; although when used in the past tense, it indicates progressive aspect. Instead, this marker is actually a mood marker together with other morphemes such as the imperative prefix *bi-* and the conditional marker *bi-* (see section 2.4.2). Hence, I believe that the verbal prefixes in Central Kurdish should only include the negation particle and the mood markers, as ordered in the following.

Negation particle > Mood Marker > Verb Stem

Except for past progressive in which the indicative marker *de-* and the negation particle *ne-* can occur together, none of these verbal prefixes can occur together especially in the present tense. That is, they are all in complementary distribution. Most importantly, despite their appearances, these inflectional morphemes especially the negative particle and the imperfective marker seem not to behave syntactically and phonologically as prefixes or even as bound morphemes (see section 3.3 for a detailed explanation).

2.4.1 *The Negation Particle*

Verbal or sentence negation in Central Kurdish is morphological rather than periphrastic. The negation morpheme is always positioned before the inflected verb, though it can be separated from the stem by a pronominal clitic in both the present and past tense, as shown in (12a) and (12b) respectively.

(12)

- | | | |
|----|-----------------------|-------------|
| a. | na=î | xo-m. |
| | NEG=3SG.CL | eat.PRS-1SG |
| | ‘I don’t eat it.’ | |
| b. | ne=man | xward-in. |
| | NEG=1PL.CL | eat.PST-3PL |
| | ‘We didn’t eat them.’ | |

There are four types (or variants) of the verbal negation morpheme in the language. The choice of each of these negators depends mainly on grammatical conditions such as tense,

aspect, and mood. The first type, *na-*, is used to negate the present indicative, seemingly replacing the indicative marker, as in (13b). As mentioned above, the negation morpheme and the indicative marker are always in complementary distribution in the present tense. There is also the possibility that the negative marker *ne-* and the indicative marker *de-* has combined via a phonological merger to form *na-*. This is possible as the indicative marker is usually pronounced as *e-* in spoken language.

(13)

- a. pîtza de-xo-m.
 pizza IND-eat.PRS.1SG
 ‘I eat pizza. / I am eating pizza.’
- b. pîtza na-xo-m.
 pizza NEG-eat.PRS-1SG
 ‘I don’t eat pizza. / I am not eating pizza.’

The second type, *ne-*, negates all past stems, as shown in (14a) and (14b). It also negates past stems when they are used for present and past perfect aspect, as in (14c) and (14d).

(14)

- a. ne=m xward-Ø.
 NEG=1SG.CL eat.PST-3SG
 ‘I didn’t eat (it).’
- b. ne=m de-xward-Ø.
 NEG=1SG.CL IND-eat.PST-3SG
 ‘I was not eating (it).’
- c. ne=m xward-û-e.
 NEG=1SG.CL eat.PST-PERF-be.PRS.3SG
 ‘I haven’t eaten (it).’
- d. ne=m xward-bû-Ø.
 NEG=1SG.CL eat.PST-be.PST-3SG
 ‘I had not eaten (it).’

Unlike in the present tense, the negation particle is not in complementary distribution with the indicate marker *de-* in past tense, as can be seen in (14b). This might be because the marker *de-* functions as a durative imperfective marker in the past tense rather than an indicative mood marker.

The third type, *me-*, is used for imperative sentences and can be considered as a prohibitive prefix, as shown in (15).

(15)

me=î	xo!
NEG=3SG.CL	eat.PRS
'Don't (you) eat (it)!'	

The last type or variant, which is *nî-*, is used to negate present tense copula verbs, as in (16a). When functioning as the main verb in the sentence, the present stem of copula 'be' is *-e* in the third singular person, whereas in other person numbers it is phonologically null. When functioning as an auxiliary verb, the present stem of copula 'be' is *-b-*. It is worth noting that the negative morpheme *ne-* is used to negate the past copula verb, as shown in (16b).

(16)

a.	ew	xwêndkar	nî-e.
	he	student	NEG-be.PRS.3SG
	'He is not a student.'		
b.	ewan	xwêndkar	ne-bû-n.
	they	student	NEG-be.PST-3PL
	'They were not students.'		

As can be seen from the above examples, the negation particle always precedes the verb stem. In sum, negation in Central Kurdish is represented by the variants of the negation particle at the beginning of the verbal complex in simple predicates with thematic verbs and at the beginning of light verbs in complex predicate constructions.

2.4.2 *The Mood Markers*

2.4.2.1 The Indicative Marker

Although Amin (2004) submits that Central Kurdish has four aspects: simple, perfective, progressive, and conditional, in terms of aspectual markers, Fattah (1997) believes that the language has only one true inflectional aspect marker, notably, *de-*, which marks a distinction between progressive and simple aspects. The distribution of this marker (used in the present tense and the past progressive) points toward some kind of imperfective meaning, and this is the reason that most traditional literature of *de-* adopts the imperfective analysis. However, as will also be argued in section 3.5, it is problematic to consider this inflectional morpheme an aspect marker. In particular, this marker is always prefixed to verbs in the present tense to convey indicative (realis modality) or future time reference. Although it can convey progressive aspect, I assume that this marker is not a pure aspect morpheme. Since there is no other marker conveying imperfective meaning, there is the possibility of the grammaticalization of this marker. The example in (17) below can have all the interpretations shown in the translation. It is worth noting that this marker is usually pronounced as *e-* in the spoken Sulaimani variety of Central Kurdish.

(17)

kebab	de-xo-m.
kebab	IND-eat.PRS-1SG

‘I eat kebab. / I will eat kebab. / I am eating kebab.’

Nevertheless, when added to verbs in past tense, it always indicates past progressive, as in (18).

(18)

kebab=im	de-xward.
kebab=1SG.CL	IND-eat.PST

‘I was eating kebab.’

The reason that this marker cannot convey indicative meaning in the past is perhaps related to the defective nature of the past stem in the language. As will be discussed in more detail in section 4.5, past stems are historically derived from the past participle.

Through a process of grammaticalization, past participle stems were used in order to convey past (see Haig (in progress)). This indicative marker *de-* was perhaps a marker used only to express non-past indicative meaning. In order to convey imperfective meaning, it has grammaticalized to perform this function.

Simple aspect in Central Kurdish is not realized by any visible morpheme, as in (19).

(19)

xward=im-in.
eat.PST=1SG.CL-3PL
'I ate them.'

In fact, as will be discussed in section 2.5, there are specific suffixes which have aspectual functions. That is, I consider aspect morphemes in Central Kurdish to be suffixes rather than prefixes. Besides, being in complementary distribution with the subjunctive and imperative markers is perhaps another evidence for considering this marker as mood marker, rather than aspect.

2.4.2.2 Subjunctive and Imperative Markers

The other mood markers in Central Kurdish can be divided into two classes. The first class conveys the speaker's commitment to the truth of the proposition, which includes the subjunctive marker *bi-*, as demonstrated in (20a). When the conditional is counterfactual, beside the prefixed marker *bi-*, the irrealis form of verb 'to be' is also used with the verb, as in (20b) (see also section 2.6.2.5).

(20)

- a. eger bi-rro-ît,
if SUB-go.PRS-2SG
'if you go,'
- b. eger bi-rroîşt-ît-aye,
if SUB-go.PST-2SG-be.PST.IRR
'if you had gone,'

The second class of mood markers, which is represented by the prefix *bi-* and is identical to the form of subjunctive mood, is used to convey imperative mood. The difference

between subjunctive and imperative mood in Central Kurdish is that ‘direct commands are restricted to a second person subject (singular or plural)’ (Fattah 1997: 146), in which the singular usually receives a phonologically null agreement morpheme, as in (21a), while the plural receives the agreement suffix *-(i)n*, as in (21b). It is worth noting that the second person singular agreement morpheme in imperative mood is *-e* when the verb stem ends in a consonant, as in (21c).

- (21)
- a. *bi-rro-Ø!*
IMP-go.PRS-2SG
‘Go!’
 - b. *kax’ez-eke* *bi-sûtên-in.*
paper-DEF IMP-burn.PRS-2PL
‘You (all) burn the paper!’
 - c. *kax’ez-eke* *bi-sûtên-e.*
paper-DEF IMP-burn.PRS-2SG
‘Burn the paper!’

As can be seen from (20) and (21) above, this inflectional marker *bi-* has the same characteristic as the indicative marker *de-* in terms of its distribution with regard to the verb. In other words, it prefixes to the verb stem and can be separated from it via pronominal clitics. This is also another determinant factor in not considering the marker *de-* as an aspect marker. As noted in the previous section, both sets of mood markers are in complementary distribution. That is, whereas one set represented by *de-* conveys realis modality, the other set represented by *bi-* conveys irrealis modality. Besides, the prefixed mood markers (the indicative marker *de-*, the subjunctive marker *bi-*, and the imperative marker *bi-*) are all in complementary distribution with the negation particle. This, however, does not mean that they cannot be negated. In fact, there seems a process of phonological merge between the mood markers and the negation particle (see section 3.5.2 for a detailed discussion).

As Fattah (1997) explains, although both the subjunctive and the imperative mood seem to have the same prefix *bi-*, they have different personal endings and are attached to different stems. The imperative *bi-* is added to a present verb stem, which is in turn followed by one of the personal endings of *-e / -Ø* or *-(i)n*, as exemplified in (22) below.

(22)

bi=î hên-e!
IMP=3SG.CL bring.PRS-2SG
'Bring it!'

The subjunctive *bi-*, on the other hand, is added to a past stem. The choice of the agreement markers is dependent on the transitivity of the verb. If the verb is transitive, a relevant pronominal clitic is used which is enclitic on the prefix *bi-*, as shown in (23a). If the verb is intransitive, a relevant verbal agreement marker is used which is suffixed on the verb stem, as shown in (23b) (see also chapter four for a detailed discussion on agreement).

(23)

- a. eger bi=m şit-aye,
if SUB=1SG.CL wash.PST-be.PST.IRR
'If I had washed,'
- b. eger bi-rroîşt-im-aye,
if SUB-go.PST-1SG-be.PST.IRR
'If I had gone,'

Another distinction between subjunctive and imperative mood is related to the use of 'if' and the past irrealis form of verb 'be' *-aye*, which are only used with the subjunctive marker, as shown in (23) above. It is worth noting that *-aye* is only used to convey imperfective past subjunctive (see also section 2.6.2.5).

In case of present subjunctive, the only difference is related to the use of agreement markers, which might explain why some linguists consider both *bi-* markers to be the same (Fattah 1997).

<u>Imperative</u>		<u>Present Subjunctive</u>	
bi-rro	'go!'	bi-ro-m	'May I go?'
bi-rro-n	'you all go!'	bi-ro-ît	'May you go?'
		bi-rw-at	'May he go?'
		bi-ro-în	'May we go?'
		bi-ro-n	'May they go?'

2.5 Suffixal Morphology

According to Fattah (1997), the verb stem can take up to seven suffixes to its right. The order of these suffixes is illustrated below.

Applicative > Participle > Passive > Conditional Marker > Verbal Agreement Markers > Additive suffix *-(i)ş* > Iterative suffix *(-ewe)*

Such an assumption, however, seems incorrect. To begin with, there does not seem to be an inflection such as applicative. Besides, the so-called ‘participle’ suffix essentially conveys the perfect aspect meaning (see also section 2.5.2), whereas the status of the iterative suffix and the additive suffix as inflectional is controversial and problematic. They cannot be considered as truly inflectional because they are not closely related to the verb stem. The degree of relevance (cf. Bybee 1985) of the inflectional morphemes to the stem can also be considered as a criterion to determine their inflectionality. A category is relevant to the extent that its meaning will substantially affect the meaning of the stem. In fact, the additive suffix *-(i)ş* can also suffix to most other parts of speech, not only the verb. Hence, these two morphemes are not considered as part of verbal inflections, and their status might need further investigation. Most importantly, the suffixes that are considered be ‘conditional suffixes’ in Central Kurdish by most researchers (e.g Fattah 1997) on the language are in fact different forms of verb ‘to be’ (see section 2.6).

Hence, the verbal inflectional suffixes are considered to be tense (although phonologically not realized), voice (passive morpheme), perfect aspect *-û/w*, and agreement markers. It is worthy of note that these suffixes cannot all co-occur at the same time. In the following, each of these categories is characterized and explained.

2.5.1 Tense

Fattah (1997: 150) believes that the distinction between the present and past in Central Kurdish is ‘coded in the stem...and in the inflections.’ However, as explained in section 2.2, the verb stem cannot contain a tense feature or tense morpheme, and there is no specific inflection indicating tense in the language. Besides, it is incorrect to assume, as Fattah does, that the present stem is the unmarked form whereas the past stem markers are manifold and unpredictable. This is because it is not conceptually possible to derive

either of the tenses from the infinitive form, as commonly assumed within literature on the language.

It is worthy of note that the assumption that the verb stem does not contain a tense morpheme does not mean that various tense-aspect distinctions cannot be expressed within the verbal complex of the language. For example, various forms of tense and aspect in the past and present can be found. Each of various tense-aspect distinctions can be conveyed via the use of mood markers, the auxiliary ‘to be’, and agreement markers (see section 2.6). What is important to note here is that in each of various verb forms of grammaticalized tense-aspect-mood there is no morpheme responsible for tense.

2.5.2 Aspect

It seems that there is only one inflectional aspect morpheme in Central Kurdish, which is the suffixed perfect marker $-û/w$. In most literature on the language (cf. Fattah 1997; Mackenzie 1961; McCarus 1958, 2009), this suffix is called ‘participle’ morpheme, which is thought to indicate past participle (Mackenzie 1961: 88). It forms ‘diphthongs or contracts with preceding vowels’ (McCarus 2009: 606) as in *xward-û* ‘having eaten’ and *kawt-û* ‘having fallen’. Since this morpheme can evidently be used to form past participle, its major function within the verbal complex is that of perfect aspect. In particular, when used in verbal structures, this suffix conveys present perfect aspect, which is formed by the past stem of the verb plus the perfect aspect suffix $-û/w$ and the copula ‘to be’, as shown in (24) below.³

³ Since the past verb stem in (24) is used, the agreement pattern is ergative; that is, there is object-verb agreement (more on agreement in chapter four). Since there is only default 3rd singular agreement and this is phonologically null in the past, in the surface only the auxiliary ‘be’ $-e$ is realized. However, when the object is plural, the verbal agreement suffix (functioning as object agreement in the past transitive) might surface as $-n$, as shown in (a) below. Thus, it is the case the agreement markers also function as copula markers particularly in the present tense. It is worth noting that most speakers tend not to use number agreement even when the object is plural, thus preferring (b) over (a).

- | | | |
|-----|--|---------------------------------------|
| (a) | sêw-eke-an=im
apple-DEF-PL=1SG.CL
‘I have eaten the apples.’ | xward-û-n.
eat.PST-PERF-be.PRS.3PL |
| (b) | sêw-eke-an=im
apple-DEF-PL=1SG.CL
‘I have eaten the apples.’ | xward-û-e
eat.PST-PERF-be.PRS.3SG |

(24)

sêw-eke=m xward-û-e.
apple-DEF=1SG.CL eat.PST-PERF-be.PRS.3SG
'I have eaten the apple.'

The past perfect, however, behaves differently from the present perfect in that it consists of a past stem and a past copula 'be' with the verbal agreement (object agreement) suffixed to the copula, as shown in the following.

(25)

sêw-eke-an=im xward-bû-n.
apple-DEF-PL=1SG.CL eat.PST-be.PST-3PL
'I had eaten the apples.'

Related to aspect is the marker *-ewe*, which is traditionally thought to be a verbal suffix (e.g. Fattah 1997). It expresses a 'contrast between a bounded (limited) situation and unbounded one, i.e. one in progress, or between a habitually occurring or merely a continuing situation' (Fattah 1997: 145). However, this marker cannot be considered as a suffix, specifically a verbal suffix. This is because it has characteristics of clitics rather than affix in that it can be added to a number of syntactic categories such as nouns and verbs. When added to verbs, it seems lexicalized to form new verbal meanings. The following is a number of verbs derived via the addition of this marker to the base form.

<u>Base Verb</u>	<u>Derived Verb from <i>-ewe</i></u>
xwardin 'to eat'	xwardin-ewe 'to drink'
hatin 'to come'	hatin-ewe 'to come back'
gerran 'to wander'	gerran-ewe 'to go back'
gêrran 'to rotate'	gêrran-ewe 'to return' or 'to narrate'

An interesting characteristic of this marker is that it can be used with both transitive and intransitive verbs. Moreover, as can be noticed from some of the examples, the meaning of this marker seems to be 'back'. Being a clitic or even an independent word rather than an inflectional suffix, it has lexical meaning and participates in forming and deriving new verbs in the language. That is, it does not modify the verb stem; hence its position follows all other inflections and agreement markers, as shown in (26).

(26)

de-gerrê-în-ewe.
IND-wander.PRS-1PL-ASP
'We will return (back).'

Since this marker has nothing to do with the syntax of verbal inflections, its status is not pursued any further.

2.5.3 *Passive*

Passive is morphologically marked on the verb stem in Central Kurdish. There are some disagreements as to what constitutes the passive morpheme. While Ameen (1960) and Mackenzie (1961) assume that passive marker is *-rê* in the present and *-ra* in the past, Fattah (1997: 149) believes differently. For him, the passive marker in both tenses is *-r*, and since, as he submits, in the passive the stem fails to show tense, the *-ê* or *-a* are added to indicate present and past respectively. In fact, he assumes that the inflections *-ê* and *-a* 'assign tense or are tense carriers in passive constructions.'

However, I believe that this conception is incorrect. It is not plausible to assume, as Fattah (1997) does, that since the stem fails to show tense in the passive, the inflections *-a* and *-ê* carry tense and that the passive morpheme is *-r*. As noted in section 2.5.1, there is no tense morpheme in Central Kurdish, and the stem, being used in passive or active clauses, does not show tense (see also section 4.5). Thus, agreeing with Ameen (1958) and Mackenzie (1961), I assume that the passive marker is *-rê* in the present and *-ra* in the past, as shown in (27a) and (27b) respectively.

(27)

- a. ew de-kuj-rê-ê(t) le layen tiroristan-ewe.
he IND-kill.PRS-PASS.PRS-3SG from side terrorist-ITER
'He will be killed by the terrorists.'
- b. ewan kuj-ra-n le layen tiroristan-ewe.
they kill.PRS-PASS.PST-3PL from side terrorist-ITER
'They were killed by the terrorists.'

It is important to note that agentless passives in Central Kurdish are more common than those with overt agents. Agents are usually expressed when they denote humans, shown

in (28), otherwise the language avoids the expression of the agent in the passive, as exemplified in (29).

(28)

Pêşmerge-eke	pek-ra-Ø.
Peshmerge	hit.PST-PSS.PST-3SG

‘The Peshmerge was hit.’

Another significant aspect concerning passivization in Central Kurdish is that it does not apply to non-agentive transitives, as demonstrated in (29). This has quite remarkable implications for the difference between the clausal structure and agreement pattern in past and present tense (see section 4.5). Note that the passive sentence like (29b) is also not possible in many languages which are not ergative.

(29)

a.	Farhad	Shîrîn=î	xosh	de-w-ê(t).
	Farhad	Shirin=3SG.CL	good	IND-want.PRS-3SG

‘Farhad loves Shirin.’

b.	*Shîrîn	de-w-rê-ê(t).
	Shirin	IND-want.PRS-PASS.PRS-3SG

‘Shirin is loved.’

As Fattah notes, all the tense-aspect-mood (TAM) combinations of verbal complex such as indicative and subjunctive can also be found with the passive.

2.5.4 Agreement Markers

There are two sets of agreement markers in Central Kurdish of which one set is affixal and the other set clitics, shown in Table 2.1. These two sets of bound pronominals are referred to in this thesis as verbal agreement markers and pronominal clitics. Verbal agreement markers are used to show subject and object verb agreement, whereas pronominal enclitics are used to double the subject in the past (show agreement with the subject), show object marking in the present only if the overt object is dropped, and show possession in nominal structures.

Table 2.1: Independent and bound pronominals in Central Kurdish

#	Person	Independent Pronouns	Pronominal Clitics ⁴	Verbal Agreement Markers	
				Set 1 (Present)	Set 2 (Past)
SG	1	min	=(i)m	-(i)m	-(i)m
	2	to	=(i)t	-î(t) / (Imp) -Ø / -e	-î(t)
	3	ew	=î	-a(t) / -ê(t) / -Ø	-Ø
PL	1	ême	=man	-în	-în
	2	êwe	=tan	-(i)n	-(i)n
	3	ewan	=yan	-(i)n	-(i)n

Verbal agreement markers are almost always used in the verbal structure. In the present tense, and for all intransitive and transitive verbs, and in past intransitive tense, verbs agree in number and person with the subject via an agreement suffix on the verb stem, as demonstrated in the following examples respectively. The verbal agreement markers are shown in boldface letters.

(30)

- a. (min) de-rro-**m**.
I IND-go.PRS-1SG
‘I am going.’
- b. (ême) kebab de-xo-**în**.
we kebab IND-eat.PRS-1PL
‘We are eating kebab.’
- c. (min) rroîşt-**im**.
I go.PST-1SG
‘I went.’

⁴ The clitic boundary is shown by the equal sign =.

Pronominal clitics are used with past transitive verbs to double the subject, as shown in (31). They are enclitic on the second constituent within the verbal complex.⁵

(31)

min	sêw-eke-an=im	xward-Ø.
I	apple-DEF-PL=1SG.CL	eat.PST-3SG

‘I ate the apples.’

Although object-verb agreement is default third person singular when overt objects are used as in (31) above, it becomes evident when the object is replaced by a bound pronominal (see also chapter four for a detailed discussion on agreement in the language). Hence, if the object in (31) is pronominal, a relevant verbal agreement marker will perform this cross-referencing function, as shown in (32).

(32)

xward-in=im.
eat.PST-3PL=1SG.CL

‘I ate them.’

It is also important to point out that pronominal clitics can cross-reference the object in present transitive clauses when the object is pronominal. Thus, when the object in (30b) is a pronominal, a relevant pronominal clitic will perform this function, as shown in (33).

(33)

ême	de=î	xo-în.
We	IND=3SG.CL	eat.PRS-1PL

‘We are eating it.’

Since the agreement markers and agreement pattern are discussed fully in chapter four, the description and characterization of the agreement morphemes are not pursued any further here. Some of their uses are nonetheless characterized in the following section.

⁵ Verbal complex roughly refers to the verb with its affixes and its object arguments. Thus, a pronominal clitic will never attach to the subject of the sentence (see section 4.3.3 for a discussion on clitic placement).

2.6 Verb Forms with Tense-Aspect-Mood

As noted throughout this chapter, the verb stems in Central Kurdish are divided into two main forms: present and past stem. In spite of their name, these stems do not contain tense features. There is even no specific morpheme representing tense in the language, as argued in section 2.5.1. Nevertheless, the various TAM distinctions can obviously be expressed in the language. Based on the use of either present or past verb stem, the following verb forms of grammaticalized TAM can be obtained in both the indicative and subjunctive moods.

2.6.1 Present Stem Verb Forms

2.6.1.1 Present Indicative

Most verbs in the present tense are used in the present indicative form. This verb form is formed of the indicative mood prefix *de-*, the present stem of the verb, and a relevant verbal agreement suffix. The transitivity of the verb does not affect the choice of the agreement morpheme. This is because, as noted in section 2.5.4, in the present tense only verbal agreement markers are used to show agreement with the subject. The negative form of present indicative is formed via the use of the negation particle *na-*, as noted in section 2.4.1. The paradigm of *rroîştin* ‘to go’ below demonstrates the verb forms in the present indicative mood.

de-/(na-)rro-m	(IND-/(NEG-)go.PRS-1SG)	‘I am (/not) going.’
de-/(na-)rro-ît	(IND-/(NEG-)go.PRS-2SG)	‘You are (/not) going.’
de-/(na-)rrw-at	(IND-/(NEG-)go.PRS-3SG)	‘S/he is (/not) going.’
de-/(na-)rro-în	(IND-/(NEG-)go.PRS-1PL)	‘We are (/not) going.’
de-/(na-)rro-n	(IND-/(NEG-)go.PRS-2PL)	‘You are (/not) going.’
de-/(na-)rro-n	(IND-/(NEG-)go.PRS-3PL)	‘They are (/not) going.’

The present indicative is used to express actions or states that are in progress, generic, habitual in the present. It is also used to refer to future time.

2.6.1.2 Present Subjunctive

The present subjunctive is formed by adding the subjunctive (irrealis) prefix *bi-* to the present stem of the verb followed by a relevant verbal agreement marker. As in the present

indicative, the transitivity of the verb does not affect the choice of the agreement morpheme. With the verb being in the present stem, the subject-agreement morpheme is always the verbal agreement marker (see also chapter four). The paradigm of the same verb *rroîştin* ‘to go’ is again used to demonstrate verb forms in the present subjunctive mood.

bi-rro-m	(SUB-go.PRS-1SG)	‘I may go...’
bi-rro-ît	(SUB-go.PRS-2SG)	‘You may go...’
bi-rrw-at	(SUB-go.PRS-3SG)	‘S/he may go...’
bi-rro-în	(SUB-go.PRS-1PL)	‘We may go...’
bi-rro-n	(SUB-go.PRS-2PL)	‘You may go...’
bi-rro-n	(SUB-go.PRS-3PL)	‘They may go...’

The present subjunctive verb form has both independent and dependent usage (Fattah 1997: 158). In its independent usage, it expresses a wish, hope, or desire on the part of the speaker. It can also be used in compliments or in greeting, as shown in (34a) and (34b) respectively. It is also used in conditional *if*-clauses, as in (34c).

(34)

- a. bi-j-ît!
SUB-live.PRS-2SG
‘May you live’
- b. be xêr bi-be-n.
with good SUB-come.PRS-2PL
‘lit. May you bring goodness’ ‘welcome!’
- c. eger bi-rro-m, tûrre de-b-ê(t).
if SUB-go.PRS-1SG angry IND-become.PRS-3SG
‘If I go, she will become angry.’

The dependent usage of the present subjunctive means that the verb form is preceded by certain elements such as modals, certain verbs that express liking or preferences, or some conjunctions or expressions that denote intention or probability. Some of these preceding elements are exemplified in (35) below.

(35)

- a. pêwîst-e bi-xwên-im.
necessary-be.PRS.3SG SUB-study.PRS-1SG
'It is necessary that I study.'
- b. wîst=man bi-rro-în.
want.PST=1PL.CL SUB-go.PRS-1PL
'We wanted to go.'
- c. be nâz-im bi-xwên-im.
with intention-1SG SUB-study.PRS-1SG
'I intend to study.'
- d. lewane-(y)e bi-xwên-im.
Perhaps-be.PRS.3SG SUB-study.PRS-1SG
'It is possible that I may study.'

2.6.1.3 Imperative and Prohibitive

As noted in section 2.4.2.2, the same irrealis prefix *bi-* used for subjunctive is also used to express imperative or prohibitive meanings. The prefix is added to the present stem of the verb followed by the agreement suffix *-e* or *-∅* for singular and *-(i)n* for plural (see also section 2.5.4), as was shown in (21) and repeated here as (36) for convenience.

(36)

- a. bi-rro-∅!
IMP-go.PRS-2SG
'Go!'
- b. kax'ez-eke bi-sutên-in.
paper-DEF IMP-burn.PRS-2PL
'You (all) burn the paper!'
- c. kax'ez-eke bi-sutên-e.
paper-DEF IMP-burn.PRS-2SG
'Burn the paper!'

The prohibitive, which is the negated imperative, is achieved by replacing the imperative prefix *bi-* with the negation particle *me-*, as noted in section 2.4.1. Hence, the example in

(36a) can be made into prohibitive by replacing the prefix *bi-* with *me-*, as shown in (37) below.

- (37)
 me-rro-Ø!
 NEG-go.PRS-2SG
 ‘Don’t go!’

2.6.2 Past Stem Verb Forms

2.6.2.1 Past Perfective

Past perfective in Central Kurdish is formed of the past stem of the verb plus an appropriate agreement morpheme. Depending on the transitivity of the verb, the subject agreement morpheme is either the verbal agreement suffix or the pronominal clitic. If intransitive, the agreement morpheme is a relevant verbal agreement suffix. If transitive, a relevant pronominal clitic is used to show agreement with the subject.⁶ Both intransitive and transitive verb paradigms are shown in the following (see also chapter four for a detailed discussion on agreement in Central Kurdish).

INTRANSITIVE

hat-im	(come.PST-1SG)	‘I came.’
hat-ît	(come.PST-2SG)	‘You came.’
hat-Ø	(come.PST-3SG)	‘S/he came.’
hat-în	(come.PST-1PL)	‘We came.’
hat-in	(come.PST-2PL)	‘You came.’
hat-in	(come.PST-3PL)	‘They came.’

⁶ In past transitive structures, the verbal agreement suffixes show default agreement with the object (see also chapter four). Since the marker is phonologically null in 3rd person singular in the past tense, it does not surface. Thus, the 3rd person singular -Ø should be inserted between the verb stem and the clitic, as shown below. This is true for all the past transitive paradigms. The implied object in the English translation is also put between optionality brackets. Thus, I have not shown this 3rd singular marker -Ø to avoid cluttering up the glosses.

xward-Ø=im (eat.PST-3SG=1SG.CL)

TRANSITIVE

xward=im	(eat.PST=1SG.CL)	‘I ate (it).’
xward=it	(eat.PST=2SG.CL)	‘You ate (it).’
xward=î	(eat.PST=3SG.CL)	‘S/he ate (it).’
xward=man	(eat.PST=1PL.CL)	‘We ate (it).’
xward=tan	(eat.PST=2PL.CL)	‘You ate (it).’
xward=yan	(eat.PST=3PL.CL)	‘We ate (it).’

Past perfective refers to actions that are completed prior to the moment of speaking. When used in subordinate clauses, it can denote future event, as in (38).

(38)

ke	hat-im,	pê=t	de-lê-m.
that	come.PST-1SG	to=2SG.CL	IND-tell.PRS-1SG
‘When I come, I will tell you.’			

2.6.2.2 Past Imperfective

Past imperfective is formed of the past stem of the verb, which is prefixed by the indicative marker *de-*. Like all verb forms in the past stem, the transitivity of the verb affects the choice of the subject agreement marker. Accordingly, in the past intransitive, the verbal agreement markers perform the subject-verb agreement, whereas in the past transitive, pronominal clitics attach to the prefix *de-* to double the subject. The following paradigms show both transitive and intransitive past imperfective verb forms.

INTRANSITIVE

de-rroîşt-im	(IND-go.PST-1SG)	‘I was going.’
de-rroîşt-ît	(IND-go.PST-2SG)	‘You were going.’
de-rroîşt-Ø	(IND-go.PST-3SG)	‘S/he was going.’
de-rroîşt-în	(IND-go.PST-1PL)	‘We were going.’
de-rroîşt-in	(IND-go.PST-2PL)	‘You were going.’
de-rroîşt-in	(IND-go.PST-3PL)	‘They were going.’

TRANSITIVE

de=m xward	(IND=1SG.CL eat.PST)	‘I was eating (it).’
de=t xward	(IND=2SG.CL eat.PST)	‘You were eating (it).’

de=î xward	(IND=3SG.CL eat.PST)	‘S/he was eating (it).’
de=man xward	(IND=1PL.CL eat.PST)	‘We were eating (it).’
de=tan xward	(IND=2PL.CL eat.PST)	‘You were eating (it).’
de=yan xward	(IND=3PL.CL eat.PST)	‘They were eating (it).’

Past imperfective is used to describe a progressive or a habitual action/event in the past. The habitual meaning is usually accomplished by an adverbial modification (Fattah 1997: 152), as shown in (39a) below. Past imperfective can also refer to unfulfilled wishes or desires, as in (39b).

(39)

- a. hemu beyanî-ek werziş=im de-kird.
every morning-INDEF exercise=1SG.CL IND-do.PST
‘I was exercising every morning.’
- b. xozge de-hat-in.
wish IND-come.PST-3PL
‘I wish they were coming.’

2.6.2.3 Present Perfect

As noted in section 2.5.2, present perfect in Central Kurdish is formed on the past stem of the verb, which is followed by the perfect aspect marker *-û/w* and the present stem of auxiliary ‘be’, which is phonologically realized only in 3rd person singular as *-e*. As can be seen in the paradigm of *rroiştin* ‘to go’, only in the 3rd person singular the auxiliary surfaces as *-e*, which might be due to the fact that the verbal agreement marker in the past tense is phonologically null (see Table 2.1 in section 2.5.4).⁷ The evidence for considering this morpheme as the present auxiliary ‘be’ can be found in past perfect aspect, in which the past stem of ‘be’ *bû* is used (see also section 2.6.2.4). Thus, the best explanation is that since the auxiliary in the present tense is phonologically null, the verbal agreement markers are used as conjugated auxiliary markers.

⁷ In fact, in some varieties of Central Kurdish the present auxiliary with intransitive verbs is realized after the verbal agreement suffix, as shown in the following example.

roîşt-û-m-e.
go.PST-PERF-1SG-be.PRS
‘I have gone.’

The transitivity of the verb affects the choice of the agreement markers. With intransitive verbs, the past stem of the verb is suffixed by the perfect aspect marker *-û*, which is in turn followed by the conjugated present form of auxiliary ‘be’. With transitive verbs, the past stem of the verb is suffixed by the perfect aspect marker *-û/w*, which is in turn followed by an agreeing pronominal clitic and the 3rd person conjugated auxiliary *-e*.⁸ The paradigms of the intransitive verb *rroîştin* ‘to go’ and the transitive verb *xwardin* ‘to eat’ in the present perfect are shown below.

INTRANSITIVE

<i>rroîşt-û-m</i>	(go.PST-PERF-be.PRS.1SG)	‘I have gone.’
<i>rroîşt-û-ît</i>	(go.PST-PERF-be.PRS.2SG)	‘You have gone.’
<i>rroîşt-û-Ø-e</i>	(go.PST-PERF-be.PRS.3SG)	‘S/he has gone.’
<i>rroîşt-û-în</i>	(go.PST-PERF-be.PRS.1PL)	‘We have gone.’
<i>rroîşt-û-n</i>	(go.PST-PERF-be.PRS.2PL)	‘You have gone.’
<i>rroîşt-û-n</i>	(go.PST-PERF-be.PRS.3PL)	‘They have gone.’

TRANSITIVE

<i>xward-û=m-e</i>	(eat.PST-PERF=1SG.CL-be.PRS.3SG)	‘I have eaten it.’
<i>xward-û=t-e</i>	(eat.PST-PERF=2SG.CL-be.PRS.3SG)	‘You have eaten it.’
<i>xward-û=î-e</i>	(eat.PST-PERF=3SG.CL-be.PRS.3SG)	‘S/he has eaten it.’
<i>xward-û=man-e</i>	(eat.PST-PERF=1PL.CL-be.PRS.3SG)	‘We have eaten it.’
<i>xward-û=tan-e</i>	(eat.PST-PERF=2PL.CL-be.PRS.3SG)	‘You have eaten it.’
<i>xward-û=yan-e</i>	(eat.PST-PERF=3PL.CL-be.PRS.3SG)	‘They have eaten it.’

The present perfect is used to express a completed action/event in the past, which still has effect in the present. Its use is mostly similar to that of the present perfect in English.

2.6.2.4 Past Perfect

Like in the present perfect, the past stem of the verb is used to form past perfect in Central Kurdish. However, unlike in the present perfect, no specific perfect aspect marker such as *-û* is used. Besides, the tense of the auxiliary ‘be’ is in the past form, which is *bû*.

⁸ There is a phonological modification with regard to the transitive third person singular. Thus, the conjugated auxiliary *-e* attaches to the verb stem; whereas the clitic will surface as the outermost of the string. Since both are vowels, it seems a consonant *t* comes between the two, as shown below.

xward-û-et=î ‘S/he has eaten it.’

Again, the transitivity of the verb affects the choice of the agreement morphemes. With intransitive verbs, the past stem of the verb is followed by the past tense auxiliary ‘be’, which is in turn followed by a relevant verbal agreement suffix, as demonstrated in the paradigm of the intransitive verb *rroiştin* ‘to go’ below. With transitive verbs, instead of the verbal agreement markers, pronominal clitics follow the past stem of the verb and the past auxiliary ‘be’, as demonstrated in the paradigm of the transitive verb *xwardin* ‘to eat’ below.

INTRANSITIVE

rroişt-bû-m	(go.PST-be.PST-1SG)	‘I had gone.’
rroişt-bû-ît	(go.PST-be.PST-2SG)	‘You had gone.’
rroişt-bû-Ø	(go.PST-be.PST-3SG)	‘S/he had gone.’
rroişt-bû-în	(go.PST-be.PST-1PL)	‘We had gone.’
rroişt-bû-n	(go.PST-be.PST-2PL)	‘You had gone.’
rroişt-bû-n	(go.PST-be.PST-3PL)	‘They had gone.’

TRANSITIVE

xward-bû=m	(eat.PST-be.PST=1SG.CL)	‘I had eaten (it).’
xward-bû=it	(eat.PST-be.PST=2SG.CL)	‘You had eaten (it).’
xward-bû=î	(eat.PST-be.PST=3SG.CL)	‘S/he had eaten (it).’
xward-bû=man	(eat.PST-be.PST=1PL.CL)	‘We had eaten (it).’
xward-bû=tan	(eat.PST-be.PST=2PL.CL)	‘You had eaten (it).’
xward-bû=yan	(eat.PST-be.PST=3PL.CL)	‘They had eaten (it).’

Past perfect in Central Kurdish conveys the meaning of a completed action/event in the past in regard to another action/event in the past. In other words, it expresses the meaning of past in the past. As Fattah (1997: 153) points out, this is the reason why past perfect is usually associated with subordinate clauses, as exemplified in (40) below.

(40)

ke	hat-im,	rroişt-bû-n.
that	come.PST-1SG	go.PST-be.PST-3PL
‘When I came, they had gone.’		

2.6.2.5 Past Subjunctive

In addition to the present subjunctive verb forms (section 2.6.1.2) and the past imperfective (section 2.6.2.2), other subjunctive or conditional forms in Central Kurdish are expressed via the use of past subjunctive verb forms. The past subjunctive has three different verb forms each of which depends mainly on the past stem of the verb and the auxiliary ‘be’ for its formation. Each different verb form is used to express a different level of conditional meaning in the language. In the following, through three different paradigms of the intransitive verb *kewtin* ‘to fall’ and the transitive verb *xwardin* ‘to eat’ the three different conditional meanings are shown.

The first past subjunctive, which can be called simple past subjunctive, is formed on the past stem of the verb followed by the auxiliary ‘be’. For the intransitive verb, the auxiliary is in its present stem form, whereas for the transitive verb, it is in the present irrealis form.⁹ As in other verb forms with past stem, the transitivity of the verb affects the choice of the agreement marker. Specifically, with intransitive verb, the agreement marker referring to the subject is the verbal agreement affix. With transitive verb, pronominal clitics refer to the subject.

INTRANSITIVE

kewt-b-im	(fall.PST-be.PRS-1SG)	‘(if) I have fallen.’
kewt-b-ît	(fall.PST-be.PRS-2SG)	‘(if) you have fallen.’
kewt-b-ê(t)	(fall.PST-be.PRS-3SG)	‘(if) s/he has fallen.’
kewt-b-în	(fall.PST-be.PRS-1PL)	‘(if) we have fallen.’
kewt-b-in	(fall.PST-be.PRS-2PL)	‘(if) you have fallen.’
kewt-b-in	(fall.PST-be.PRS-3PL)	‘(if) they have fallen.’

⁹ The present irrealis form of auxiliary ‘be’ is *-bêt*, which is formed with the present stem of copula *bûn* ‘be’ plus the 3rd agreement verbal marker *-ê(t)*. The past irrealis form is *-aye*, which is added to the present stem of copula *bûn* ‘to be’. This contrast is shown below.

- | | | |
|----|-------------------------------------|----------------|
| a) | de-bêt | bi-rro-m. |
| | IND-be.PRS.IRR | SUB-go.PRS-1SG |
| | ‘It is necessary that I go.’ | |
| b) | de-b-(w)aye | bi-rro-m. |
| | IND-be.PRS-PST.IRR | SUB-go.PRS-1SG |
| | ‘It was necessary that I would go.’ | |

TRANSITIVE

xward-bêt=im	(eat.PST-be.PRS.IRR=1SG.CL)	‘(if) I have eaten (it).’
xward-bêt=it	(eat.PST-be.PRS.IRR=2SG.CL)	‘(if) you have eaten (it).’
xward-bêt=î	(eat.PST-be.PRS.IRR=3SG.CL)	‘(if) s/he has eaten (it).’
xward-bêt=man	(eat.PST-be.PRS.IRR=1PL.CL)	‘(if) we have eaten (it).’
xward-bêt=tan	(eat.PST-be.PRS.IRR=2PL.CL)	‘(if) you have eaten (it).’
xward-bêt=yan	(eat.PST-be.PRS.IRR=3PL.CL)	‘(if) they have eaten (it).’

Although the main verb is in the past stem form, the time of the sentence is present. This is obviously due to the auxiliary ‘be’, which is in present irrealis form. Simple past subjunctive is used to express hypothetical or improbable situations in the past, which still have an effect in the present, as can be seen in (41).

(41)

eger	xward-bêt=im,	pê=t	de-lê-m.
if	eat.PST-be.PRS.IRR=1SG.CL	to=2SG.CL	IND-say.PRS-1SG
	‘If I have eaten (it), I will tell you.’		

The second past subjunctive, which can be called imperfective past subjunctive, is again formed on the past stem of the verb, which is preceded by the subjunctive (irrealis) prefix *bi-* (see also section 2.4.2.2). It is worth noting that the prefix can sometimes be dropped. The auxiliary ‘be’ is again used with this verb form albeit differently from that of the first past subjunctive. The auxiliary is in the past irrealis form, which is *-aye*. Almost all literature (e.g. Fattah 1997; McCarus 2009; Öpengin 2013) on the language considers this *-aye* as a (conditional/subjunctive) suffix. However, it is actually the past irrealis form of auxiliary ‘be’. In fact, considering *-aye* as a suffix seems problematic for the derivation of the verbal complex and the TP structure in the language (see section 3.4). The paradigms of *kewtin* ‘to fall’ and *xwardin* ‘to eat’ are given for illustration in the second past subjunctive.

INTRANSITIVE

bi-kewt-im-aye	(SUB-fall.PST-1SG-be.PST.IRR)	‘(if) I had fallen.’
bi-kewt-ît-aye	(SUB-fall.PST-2SG-be.PST.IRR)	‘(if) you had fallen.’
bi-kewt-∅-aye	(SUB-fall.PST-3SG-be.PST.IRR)	‘(if) s/he had fallen.’
bi-kewt-în-aye	(SUB-fall.PST-1PL-be.PST.IRR)	‘(if) we had fallen.’

bi-kewt-in-aye	(SUB=fall.PST-2PL-be.PST.IRR)	‘(if) you had fallen.’
bi-kewt-in-aye	(SUB=fall.PST-3PL-be.PST.IRR)	‘(if) they had fallen.’

TRANSITIVE

bi=m xward-aye	(SUB=1SG.CL eat.PST-be.PST.IRR)	‘(if) I had eaten (it).’
bi=t xward-aye	(SUB=2SG.CL eat.PST-be.PST.IRR)	‘(if) you had eaten (it).’
bi=î xward-aye	(SUB=3SG.CL eat.PST-be.PST.IRR)	‘(if) s/he had eaten (it).’
bi=man xward-aye	(SUB=1PL.CL eat.PST-be.PST.IRR)	‘(if) we had eaten (it).’
bi=tan xward-aye	(SUB=2PL.CL eat.PST-be.PST.IRR)	‘(if) you had eaten (it).’
bi=yan xward-aye	(SUB=3PL.CL eat.PST-be.PST.IRR)	‘(if) they had eaten (it).’

This past subjunctive verb form is used to express an unreal or hypothetical action in the past. In particular, it conveys a hypothetical situation in the past, as exemplified in (42a). It can also express an unrealized wish in the past, as in (42b).

(42)

- a. eger zû bi-rroîşt-im-aye,
if early SUB-go.PST-1SG-be.PST.IRR
‘If I had gone early,’
- b. birya ne-rroîşt-im-aye.
if only NEG-go.PST-1SG-be.PST.IRR
‘I wish I hadn’t gone.’

The third past subjunctive verb form, which can be called past perfect subjunctive, is also formed on the past stem of the verb plus the past form of auxiliary ‘be’. As noted in section 2.6.2.4, the past tense of auxiliary ‘be’ is used in past perfect tense in Central Kurdish. Besides, like the imperfective past subjunctive, the past irrealis form of the verb *bûn* ‘to be’, which is *-aye*, is again used. The transitivity of the verb stem affects the choice of the agreement markers, as demonstrated below with the paradigms of the intransitive verb *kewtin* ‘to fall’ and the transitive verb *xwadin* ‘to eat’.

INTRANSITIVE

kewt-bû-m-aye	(fall.PST-be.PST-1SG-be.PST.IRR)	‘(if) I had fallen.’
kewt-bû-ît-aye	(fall.PST-be.PST-2SG-be.PST.IRR)	‘(if) you had fallen.’
kewt-bû-Ø-aye	(fall.PST-be.PST-3SG-be.PST.IRR)	‘(if) s/he had fallen.’

kewt-bû-în-aye	(fall.PST-be.PST-1PL-be.PST.IRR)	‘(if) we had fallen.’
kewt-bû-n-aye	(fall.PST-be.PST-2PL-be.PST.IRR)	‘(if) you had fallen.’
kawt-bû-n-aye	(fall.PST-be.PST-3PL-be.PST.IRR)	‘(if) they had fallen.’

TRANSITIVE

xward-bû=m-aye	(eat.PST-be.PST=1SG.CL-be.PST.IRR)	‘(if) I had eaten (it).’
xward-bû=ît-aye	(eat.PST-be.PST=2SG.CL-be.PST.IRR)	‘(if) you had eaten (it).’
xward-bû=î-aye	(eat.PST-be.PST=3SG.CL-be.PST.IRR)	‘(if) s/he had eaten (it).’
xward-bû=man-aye	(eat.PST-be.PST=1PL.CL-be.PST.IRR)	‘(if) we had eaten (it).’
xward-bû=tan-aye	(eat.PST-be.PST=2PL.CL-be.PST.IRR)	‘(if) you had eaten (it).’
xward-bû=yan-aye	(eat.PST-be.PST=3PL.CL-be.PST.IRR)	‘(if) they had eaten (it).’

The past perfect subjunctive verb form is used to convey unreal or hypothetical actions/situations in the past. The action or situation is farther in the past than that of the imperfective past subjunctive. Being of perfect aspect, the action is seen from a specific point of time established in the past, as shown in (43).

(43)

eger	dwênê	nan=im	xward-bû-aye...
if	yesterday	bread=1SG.CL	eat.PST-be.PST-be.PST.IRR
‘If I had eaten yesterday...’			

2.7 Summary

This chapter has basically characterized the verbal morphology in Central Kurdish. Resolving a number of incorrect assumptions about the status of certain verbal morphemes was one of the main aims of the chapter. Contrary to common understanding and assumption on the verbal morphology of Central Kurdish, it was manifest that the verb stem does not take as many as seven suffixes. Excluding the preverbal particles from the inflectional prefixes, only two main sets of prefixes, which are in complementary distribution, were proposed. Moreover, although the verb stem is always either in the present or past stem form, no specific tense morpheme is suggested for the language. Still, the various tense-aspect-mood distinctions could be found. Particularly, it was observed that the auxiliary ‘be’ plays a significant role in a number verb forms such as perfect aspect and subjunctive forms. The findings of this chapter have important implications

for the overall verbal structure of the language. Without such groundwork characterization, the analysis proposed in the coming chapters would prove problematic.

Chapter 3. The Structure of TP in Central Kurdish

3.1 Introduction

The main aim of this chapter is to propose an account of the structure of the verbal complex and the clause structure in Central Kurdish. As seen in the previous chapter, the verb stem contains both prefixal and suffixal morphology. These affixal verbal inflections represent functional categories in the language in that they belong to syntactic projections. Hence, characterising and representing each of these verbal affixes within the syntactic structure provides a basic clausal structure of the language. There are different mechanisms for deriving the verbal complex within syntactic theory. Each of these mechanisms corresponds to different types of affixes; for instance, head movement is responsible for the derivation of verbal suffixes.

Since Central Kurdish contains both prefixal and suffixal verbal morphology, it is necessary to find out how the verbal complex in the language can be derived. As will be seen, two different mechanisms for their derivations are required. In particular, it is established that the verbal affixes in Central Kurdish have different syntactic and phonological characteristics. The prefixes, which are principally the mood markers and the negation particle, have different phonological characteristics from suffixal morphemes. The fact that the prefixes have different properties from the suffixes is an indication that they are derived by different mechanisms.

The chapter is organized as follows. In the next section, inflectional morphology is discussed within the syntactic theory, giving a brief theoretical background about how inflections can be accounted for in the syntax. In particular, a number of proposals regarding the derivation of the verbal complex through head movement and phrasal movement are discussed and evaluated to see whether they can apply to complex verbal structure of Central Kurdish or not. Section 3.3 examines how the prefixes in the language have different morpho-phonological characteristics from the suffixes. This finding helps in accounting for the derivation of prefixes and suffixes. The derivation of the verbal complex is thus discussed in section 3.4. Section 3.5 examines the various functional projections that constitute the Central Kurdish clause. Section 3.6 deals with the problems of word order, arguing specifically for the position of arguments within the verbal

complex. In section 3.7, a number of recalcitrant residues are presented. The last section of this chapter provides a brief summary of the findings.

3.2 Inflectional Morphology and Syntax

Within syntactic theory, it is widely assumed that the internal structure of (complex) words share many characteristics of sentence structure (Holmberg and Roberts 2013). There is a close relation between the morphological structure and syntactic structure. Morphology and syntax share a number of categories and features such as nouns, verbs, tenses, cases, etc. Most importantly, they both display hierarchical structure and headedness. Hence, any adequate grammatical theory needs to provide an account for the interaction and correlation between the two.

Verbal morphology is a stark example of this correlation. Whereas a specific meaning can be conveyed via a string of words in one language, the same meaning may be conveyed by a set of inflections on a lexical item in another language. This means that the various languages of the world have different morphology. This is reflected in the classification of the languages into analytic/isolating (with few or no inflections), inflectional/fusional (with many inflections fused together), agglutinating (with many inflections in a near one-to-one form-to-meaning mapping), and polysynthetic (with more than a single lexical root being interspersed with inflection in a complex word) (Holmberg and Roberts 2013: 112).

Central Kurdish seems to be an example of agglutinating languages. The verb root has a number of inflections in a near one-to-one form-to-meaning mapping creating a verbal complex. Given that the internal structure of complex words in agglutinating (or polysynthetic) languages denotes the same logical content as the internal structure of a sentence in isolating languages, accounting for the syntax of the verbal inflections will be determinant for many significant aspects of the clausal syntax of the language. In other words, the internal structure of inflected words is closely related to sentential structure.

The non-lexicalist approach to complex word-formation is adopted in this thesis, as noted in chapter one. In this approach, the syntactic component of language constructs words and phrases alike. A pioneer for proposing the non-lexicalist approach within generative framework is Mark Baker (see Baker 1985, 1988). His ‘Mirror Principle’ played a vital

role in the development of non-lexicalist approach to morphological complex words. Accordingly, in languages in which morphological reordering is possible the morphological structures ‘mirror’ the syntactic structures (Baker 1985). As Harley (to appear: 14) explains, in non-lexicalist theories, ‘there is no distinct word-formation module, and word-internal structure participates in syntactic operations and semantic interpretation in the same way that word-external structure does’.

Deriving morpheme orders is thus supposed not to include any non-syntactic operations. In particular, in such an approach, morphemes constitute the terminal nodes of syntactic projections. While there are different non-lexicalist approaches, almost all of them assume a rich functional structure in the syntactic tree. It is widely considered, for example, that the combination of verbal root and its inflectional morphology is derived through verb movement. This movement is seen as an instance of incorporation, in the sense of Baker (1988). Thus, the various morphological categories of a verb are analyzed as heading their own projections in the syntax. This means that the order of affixes in the resulting verb reveals the respective order of attachment in the syntactic tree, as argued in Cinque (1999).

The question that arises at this point is how to derive the verbal complex in Central Kurdish considering the fact that verbs in Central Kurdish always end up attached to a number of suffixes such as the agreement markers, the passive morpheme, or the perfect aspect marker, and a number of prefixes such as the negation particle or the mood markers. In the non-lexicalist perspective the question is: what is the structure of TP such that it allows derivation of the verbal complex? In the following subsections, a number of proposals regarding the derivation of the verbal complex through head movement and phrasal movement are discussed and evaluated to see whether they can apply to complex verbal structure of Central Kurdish or not.

3.2.1 *Head Movement*

Head movement, in which a syntactic head moves and adjoins to the next higher head obeying the Head Movement Constraint of Travis (1984), is a well-established analysis within current syntactic theory. It was seen as a core syntactic operation within the Government and Binding theory and early versions of the minimalist program. The effects of this conception were observed in a number of syntactic phenomena, such as

verb-movement in French/Romance languages, verb-movement to C in German, English subject-auxiliary inversion, French subject-clitic and complex inversion, noun-incorporation, Italian Aux-to-Comp, clitic movement, and many other phenomena (see Roberts (2001, 2010) for an overview).

Iterated head movement will result in the formation of potentially highly complex words. A complex head formed by head movement will necessarily behave as a word, its internal morpheme order mirroring the base generated order of the heads involved. In other words, the surface morpheme order of a complex word will thus be exactly the opposite of the order of the corresponding syntactic heads in the base structure, only if the structure is right-branching (see Holmberg and Roberts 2013). In this way, the internal structure of the complex word corresponds to the structure of phrases and sentences, as stated above, conforming to Baker's Mirror Principle.

Adopting Kayne (1994)'s LCA theory means that syntax should be subject to the following restrictions:

- (1) *Restrictions on syntax* (Julien 2002: 36)
- a. Nodes are binary branching or nonbranching.
 - b. Asymmetric c-command maps into linear precedence.
 - c. Syntactic movement is always to the left.
 - d. Adjunction is always to the left.

Accordingly, head movement mechanism allows two heads, X^0 and Y^0 , to have only one configuration. The two heads would thus be included in a complex Y^0 , which is a complex syntactic head that could be formed by head movement, as indicated in (2).

(2)

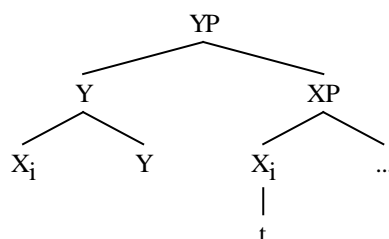

Complex verbal words can be argued to be derived by successive incorporation of verbal heads. In fact, head movement is the method of deriving them in a number of languages

of the world, especially those that have verbal inflectional suffixes and verb-medial or verb-initial word order (Julien 2002). Northern Saami is an example of such a language. It can be argued, for example, that the verbal complex in the Northern Saami sentence in (3) is formed in syntax by head movement. In the underlying structure each functional category is a head. The verb root head-moves into its functional domain, picking up the heads one by one, always by left-adjoining to it, which results in a complex verb with a sequence of suffixes.

(3)

Northern Saami (Julien 2002: 56)

Mu-n	vastid-i-n	oanehaccat.
I-NOM	answer-PST-1SG	briefly

‘I answered briefly.’

The structure of the sentence is (4). The verb moves first to T°, left-adjoining to it. Then T, now incorporating the verb, moves to Pol° which hosts polarity, before finally moving to Fin°, which Julien argues hosts subject-verb agreement in Northern Saami (Julien 2002: 57).

(4)

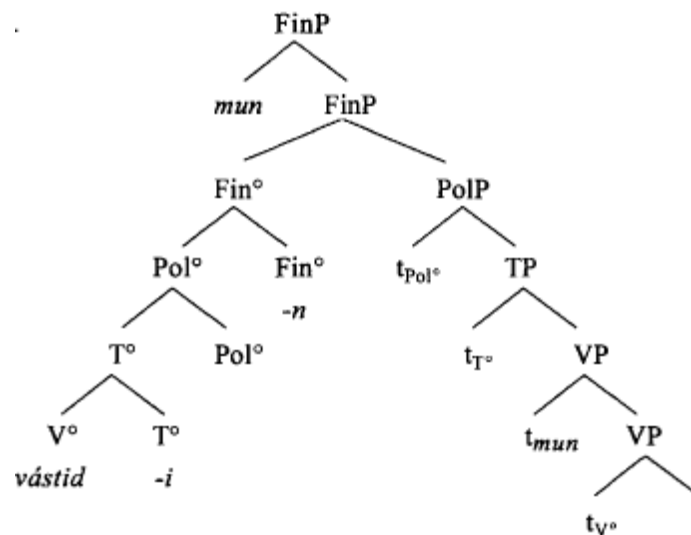

The trigger for head-movement, according to Julien (2002: 58), is a ‘strong feature of the host that induces the host to incorporate the head of its complement’. A head that attracts another head has a strong head feature. She also assumes that a head that takes a

complement has a ‘complement selectional feature, or c-feature’. Following Svenonius (1994) and Holmberg (2000), she believes that this feature specifies the category of the complement of the head. The c-feature is also uninterpretable in the sense of Chomsky (1995). Thus, to be interpreted, the relevant feature of the complement needs to be moved to the checking domain of the selecting head.

Even if head movement can be seen as the right method for forming complex words, there are still some problems. In particular, the head movement mechanism encounters problems when we look at verb-final languages, such as Central Kurdish or Turkish, as shown in the following examples.

(5)

Central Kurdish

Min	kebab	de-xo-m.
I	kebab	IND-eat.PRS-1SG

‘I eat/am eating kebab.’

Turkish (Kornfilt 1997: 219)

Ben	kitab-I	oku-du-m.
1SG	book-DEF.OBJ	read-PST-1SG

‘I read the book.’

Both examples show that the subject agreement marker is the final suffix on the verb stem. Assume that the verb moves to the subject licensing head, say T, containing agreement features. This would allow subject-verb agreement in a spec-head relation. At the same time, as the examples clearly show, in both languages the object comes between the verb and the subject. This is obviously problematic, especially if a given head can only have one specifier, which is required by the antisymmetry theory (Kayne 1994). In discussing the Germanic SOV languages, Kayne maintains that the subject must move higher than the subject licensing position which thus leaves space for the object to be also positioned above the verb (Kayne 1994: 52). In other words, under the head-movement theory of SOV structures both arguments surface in positions that are higher than the positions in which they get case-marked and/or trigger agreement.

Another possible problem with head-movement is related to languages that have both verbal prefixes and suffixes. As characterized in chapter two, Central Kurdish can

schematically have the following affixes attached to the verb stem. It is worthy of note that the occurrence of all of them together is not possible.

Negation > Mood > Verb stem > Aspect > Passive > Agreement

According to the head movement mechanism, if the verb head-moves to attach to its inflectional markers, and if head-movement is strictly done by left-adjunction of the moved head to the target head, one should expect to find only suffixes in Central Kurdish, so that the verb stem must be positioned as the left-most of the verbal complex and be followed by its inflectional markers. Clearly, this is not the case in the verbal complex of the language. The fact that verb stems can be preceded by preverbal morphemes such as the mood markers or the negation particle is an argument for considering other mechanisms alongside head-movement, particularly in the derivation of verbal prefixes in the language. In other words, even if head movement can derive suffixes, it cannot derive verbal prefixes in Central Kurdish.

Related to head movement to derive the verbal complex is a study of West Germanic OV languages by Haegeman (2000), in which she attempts to come up with a possible account of such languages. She proposes that the West Germanic OV order be derived by (i) morphology-driven V-movement to a functional head, i.e., V-to-T movement, and (ii) remnant movement of the extended projection of V to Spec-TP. Based mainly on comparative data from Indo-European languages such as French and English, it is generally assumed that there is a correlation between V-movement and inflectional morphology (cf. Pollock 1989). Under this hypothesis, if verbs carry tense suffixes, it follows from the syntactic approach to word formation that the verbs must have moved at least to T head.¹⁰ The current standard idea is that agreement triggers V-to-T or V-to-AGR (cf. Holmberg and Roberts 2013). Central Kurdish has a fair amount of overt inflectional morphology, which might lead one to expect V-to-T movement.

Nevertheless, Haegeman's proposal cannot account for the derivation of verbal complex in Central Kurdish. Although in many languages, including many Indo-European ones, tense and agreement occur together, this is not the case in Central Kurdish, where tense has no morphological realization. As argued in chapter two, the verb stem does not seem

¹⁰ There also exists the remnant movement hypothesis where inflected forms are derived by remnant XP movement. This method is discussed in the next section.

to contain a tense feature, more specifically a tense suffix. Hence, there is no operation or movement of the verb to the tense head (see also chapter four).

Although head movement as a syntactic analysis faces no obvious problem within GB theory and this continued through early versions of minimalism, the picture changes somewhat in (Chomsky 1995: ch. 4) partly as a consequence of the abandonment of Agr as a syntactic category. An alternative to head movement can thus be seen in the ‘checking’ theory of Chomsky (1995), which claims that words emerge fully derived and inflected in syntax where they must be checked against the functional categories at LF within their checking domain, the spec-head relation. And, in order for the lexicon to generate inflectionally and derivationally preformed words, it must contain some kind of morphological component which is responsible for attaching prefixes, suffixes, and infixes. As noted in chapter one, lexicalist approaches for deriving words is not adopted in this thesis. Besides, pure syntactic approaches will have greater advantages over lexicalist approaches in that no further additional mechanism or morphological component is needed. For example, in a lexicalist theory, the order of the suffixal morphemes in the above example of (3) needs some additional mechanism to ensure that the suffixes are ordered in a way which corresponds to the order of heads in the syntactic structure that the complex word is inserted into. In other words, one would need a principle such that checking operates from the inside out. If not, an explanation for the surface order of the morphemes must be either ignored or be seen as accidental. In the head movement approach, however, such additional mechanism is not necessary.

However, it was not until Chomsky (2001a: 37-38) that a number of reasons were given in order to suggest excluding head movement from the core operations of the narrow syntax. In the first place, Chomsky states that head movement does not affect interpretation: ‘the semantic effects of head-raising in the core inflectional system are slight or non-existent, as contrasted with XP-movement’ (Chomsky 2001a:37). For example, the different structural positions of verbs in finite clauses in the languages of French and English are usually analyzed in terms of different extents of head movement (as in Pollock 1989). This, however, leads to the expectation that there may be some LF-related differences between verbs in those two languages. And, since these LF-related differences are not found, Chomsky suggests that head movement be confined to the PF part of the grammar. Secondly, another problem with head-movement is related to the c-

command issue in that the moved head is unable to c-command its trace/copy in the derived structure. This is true if the most natural definition of c-command is maintained (see Chomsky 2000: 116). Yet, if a definition of the kind assumed in Kayne (1994: 18) is adopted, which, as can be seen in (2), allows an adjoined category to c-command both the category to which adjoins, the moved head would then be able to c-command its trace in a head movement configuration. Still, Chomsky does not prefer such complications of the definition of c-command because they do not ‘fall under the notion of c-command from Merge’ (Chomsky 2000: 116). This is why head movement is seen as inconsistent compared to other types of movement in that the moved head does not c-command its trace. Other problems with the head movement mechanism is related to the nature of the trigger of head movement, and the idea that the derived structure of head movement is countercyclic (see Chomsky 2001a; Roberts (to appear) for a detailed discussion related to the problems concerning head movement).

It is worth noting although Chomsky’s arguments lead to some kind of a re-evaluation of head movement, no specific theoretical principle is suggested which ultimately eliminates head movement from narrow syntax. Nonetheless, since Chomsky (2001a), there has been a number of alternatives to syntactic head movement. These include PF-movement approach, which Chomsky himself advocated, and the remnant-movement or phrasal movement approach (see section 3.2.2). PF-movement, though unproblematic in the sense that it does not have to obey certain syntactic conditions such as the c-command condition, is not favored in this thesis. This is because, as Roberts (to appear) suggests, decisive evidence for PF-movement is somewhat missing. In addition, as noted in chapter one, approaches within the Distributed Morphology such as Merger Under Adjacency are not favored in this thesis. In fact, as Roberts (to appear) explains, none of the main alternatives to the standard head movement is totally free of problems, and none appears to be a universal alternative to the standard head movement in the sense that all former cases of head movement can be reanalyzed in the relevant terms. For these general reasons and other factors discussed in section 3.4., the head-movement mechanism is considered the method of deriving the suffixes in Central Kurdish as the verb can move to each functional head to pick it up.

3.2.2 Phrasal Movement

An alternative to head-movement in head-final constructions is phrasal movement (Jayaseelan 2010; Julien 2000, 2001, 2002; Holmberg 2000; Kayne 1994; Svenonius 2006, among others). Hence, since Central Kurdish is an OV language, it is reasonable to consider the possibility that the different mechanisms of phrasal movement be applied in order to derive its verbal complex and the order of the inflected verb with its complements.

According to Jayaseelan (2010), verbal stems and their suffixal inflection come together by a special type of phrasal movement which is ‘remnant-VP preposing’ (Jayaseelan 2010: 298). This operation can be analyzed as two movements: the “evacuation” of a V’s complement out of the VP (termed *stacking*), and the movement of the “evacuated” VP to the (immediate) left of the head hosting the inflection which is morphologically realized as a suffix on V. His analysis, as he himself submits, is anticipated by an earlier theory by Koopman and Szabolcsi (2000) of Hungarian word order. From their theory, he adopts the important notion of ‘stacking’, with some modifications. As Jayaseelan maintains, if the verb has arguments, they must be ‘stacked’ in the specifiers of abstract heads whose only function is to provide landing sites for these elements; and these ‘stacking’ positions are weakly bonded to the VP complex that comes below them. The subsequent VP movement can strand or pied-pipe the stacked material, giving rise to VO or OV order.

Jayaseelan (2010: 303) suggests that English is a language in which all the material to the right of the verb is moved out into a stacking position Spec-XP; and then moves the remnant VP into Spec-TP, stranding the stacked material. These two operations bring about the VO order in English. Therefore, a string such as *smokes cigars* will be generated by two movements shown in (6) (taken from Jayaseelan 2010: 304).

(6)

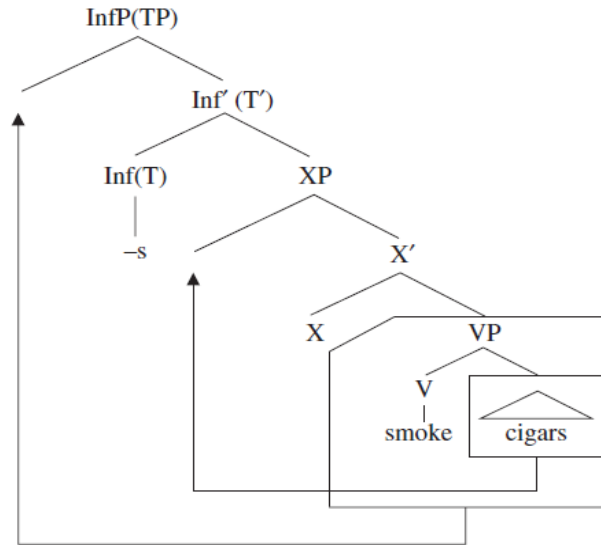

For head-final languages, he again suggests that the material to the right of the verb moves into a stacking position, Spec-XP. However, different from head-initial languages, when the VP moves into Spec-TP to pick up the inflection, the stacked material is carried along. That is, in case of OV order, the VP movement pied-pipes the stacked material and all the structure below T^0 . Hence, instead of a diagram like (5), for an OV language there is (7).

(7)

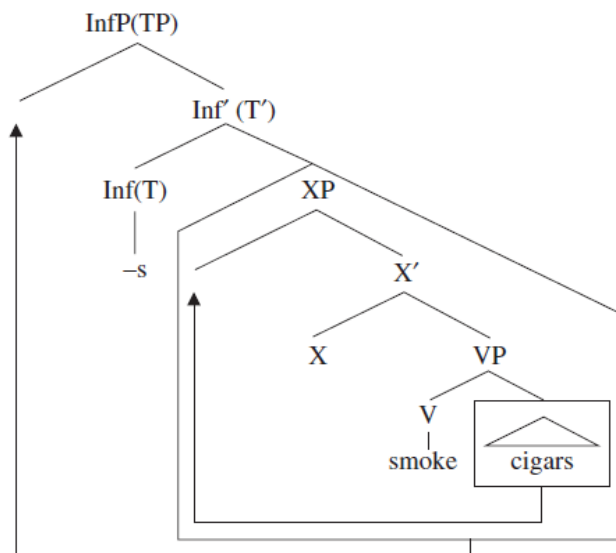

Jayaseelan (2010) believes that his 'uniform algorithm' can apply equally to VO and OV languages, and the difference between VO/OV orders falls out from the stranding/pied-

piping choice which the algorithm offers. He further adds that the algorithm is ‘morphologically motivated by the fact that inflections are generated above verbal stems and the two need to get together in some fashion’ (Jayaseelan 2010: 306). An advantage of this analysis, as he submits, is that it solves the problem of all antisymmetric accounts of OV languages—namely, how to move verb complements out of the VP. The problem is solved in that the stacking operation is assumed to be a property of UG, not a unique operation that only OV languages require.

His proposed algorithm is believed to bring verbal stems and their inflections together in all languages that have suffixal inflection on verbs. However, as he himself admits, an operation like stacking will only be necessary to suffixal verbal morphology, not to prefixal morphology, or the case in which elements like tense are independent particles (Jayaseelan 2010: 306). As a result, his analysis would work for Central Kurdish if the language had only suffixal verbal morphology, which is not the case, as we have seen.

The theory works well as long as the prefixes are structurally lower than the suffixes; in that case the stacking position can be higher than the prefix heads, and the order will be derived. However, in Central Kurdish, inflectional morphemes such as the negative particles and the mood markers (the indicative marker, the subjunctive and imperative markers) occupy functional heads that are positioned above TP (see also section 3.4). Thus, in case the prefixes are structurally higher than the suffixes, as it is the case in Central Kurdish, the theory does not work. This is because a wrong morpheme order will be achieved in which the object will intervene between the verbal prefixes and the verb stem, as shown in (8).

(8) Prefixes-Object-Verb Stem-Suffixes (Wrong morpheme order in Central Kurdish)

Even putting the problem of prefixes aside, it is still not clear how other inflectional suffixes are derived bearing in mind the verb in Central Kurdish can take a number of suffixes such as the perfect aspect and the agreement markers. Furthermore, as will be seen in section 3.4, it is the case that the subject is positioned high in the structure within the CP domain. With regard to the object, there are good arguments to support its movement out of VP to positions above TP. For these reasons, Jayaseelan’s analysis is not adopted here.

Unlike Haegeman (2000), Julien (2000, 2001, 2002) uses phrasal movement to bring together V and its suffix—but only in OV languages; in VO languages it would be the result of head-movement. According to Julien (2002), following a suggestion by Kayne (1994), verbs and suffixes come together by the successive movement of a verb phrase containing both the arguments and the verb into the specifier positions of the functional heads of TP. This method is not usual or generally recognized as a source of word formation. In addition, Julien (2002) submits that verb final languages are consistently head-final at least as far as their TP is concerned. She further argues that the surface head-final order is derived by moving the complement of every inflectional head to the specifier of the phrasal projection of the head. Thus, with the complement in specifier, the head will appear as the final element of its phrase. At the same time, as long as the complement in specifier position is also head-final, the inflectional head will be immediately preceded by the head of its complement in the surface order, and, consequently, the sequence of heads can be perceived as a complex word.

In fact, Julien claims that in head-final languages, phrasal movement is the principal and perhaps the only means of deriving complex words. The verbal complex in the following example of Lezgian, an OV language, can be derived via phrasal movement of VP containing both arguments and the verb into the Spec-TP, and then the whole TP moves into the Spec-EvidP, as shown in the schematic structure in (10), where the clause initial locative phrase ‘in Baku’ is located in the Spec-TopP.

(9)

Lezgian (Haspelmath 1993: 148 as cited in Julien 2002: 116)

Baku.d-a	irid	itim	gülle.di-z	aqud-na-lda.
Baku-INESS	seven	man.ABS	bullet.DAT	take.out-AOR-EVID

‘They say that in Baku seven men were shot.’

(10)

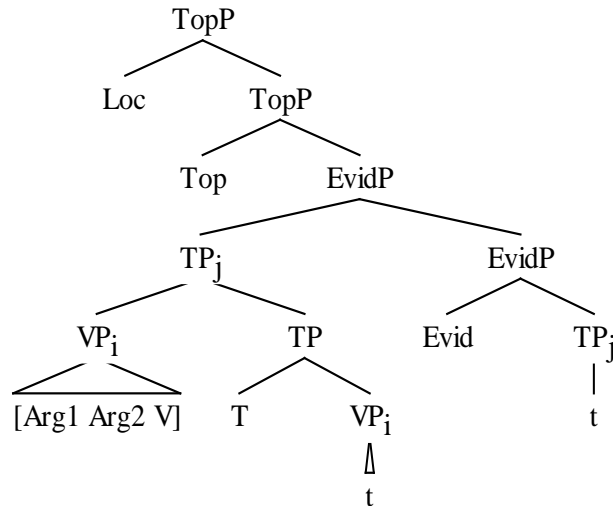

As can be seen in (10), the verbal word is made up of a sequence of heads that have become linearly adjacent due to the successive movements of complements to the nearest specifiers. As a result, every phrase within the IP domain is made head-final. Moving a phrase into the specifier of the next higher head will thus result in the heads being linearly adjacent to each other, and the two heads will be seen as one word. This method is in fact suggested for agglutinating SOV languages by Kayne (1994: 52-54).

Given the LCA, which only allows leftwards movement, the phrasal movement mechanism can only derive inflected words with suffixes. As shown in the schematic tree in (11) (see also (23) for a basic schematic structure in Central Kurdish), applying phrasal movement understood in terms of Julien (2002) to the verbal complex of Central Kurdish means that the verb with its arguments must first move to the specifier of a functional head of the suffixes, and subsequently the so derived phrase will move to the specifier of the next functional head. In other words, the VP, containing its arguments, must first move to pick up the suffixes in roll-up fashion before the whole phrase moves to the Spec-TP.

(11)

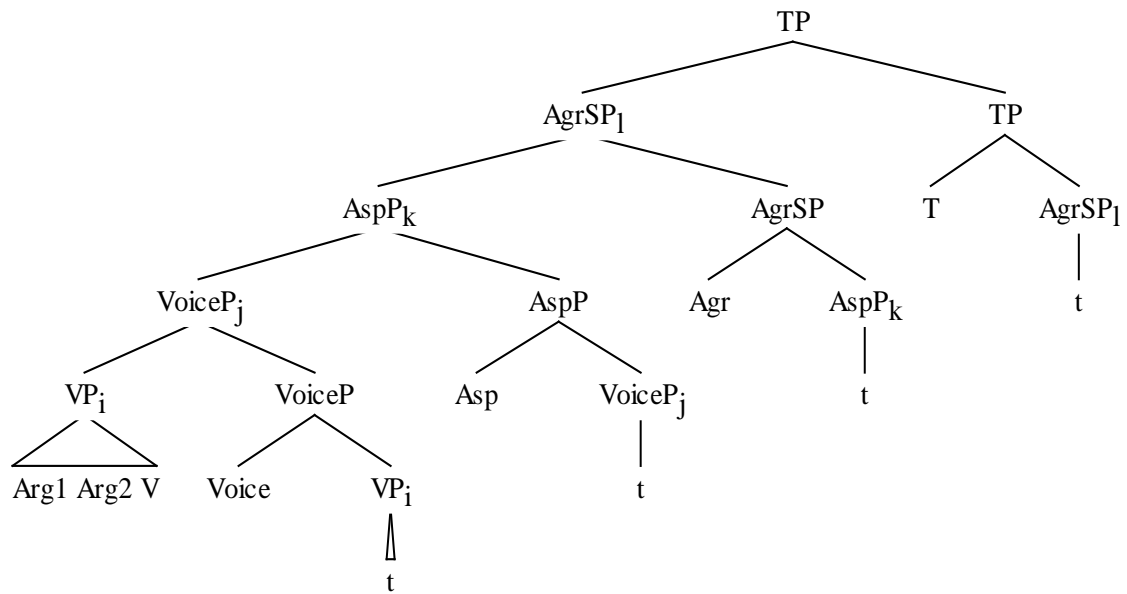

However, the successive roll-up movement of VP with its arguments will not produce the desired morpheme order given the fact that arguments in Central Kurdish precede the prefixes. That is, the desired order in (12a) will not be produced. Instead, successive movements of complements into the nearest specifier will derive the order in (12b), which is not a possible morpheme order in the language.

(12)

- a. Arg1-Arg2-Prefixes-Verb stem-Suffixes (Desired morpheme order in Central Kurdish)
- b. Prefixes-Arg1-Arg2-Verbs stem-Suffixes (Incorrect morpheme order driven by phrasal movement)

An example such as (13), where both arguments and the indicative marker *de-* precede the verb, poses a problem to Julien's theory of phrasal movement to derive the verbal complex. Thus, since the verb in Central Kurdish can take both prefixes and suffixes, it is not possible to derive the verbal complex just by successive phrasal movement to Spec-TP.

(13)

ew perrtûk de-kirr-êt.
He book IND-buy.PRS-3SG
'He buys/is buying books.'

The important questions at this point are: If the verbal complex in Central Kurdish contains both prefixes and suffixes, how is it possible to derive verbal complex syntactically? Is it possible to have two different operations for the verbal affixes in Central Kurdish? The answers to these questions are presented in the following sections.

3.3 Prefixation vs Suffixation

Based on some of the general properties of head-final languages that Julien (2002) discusses, the morphology of these languages is assumed to be predominantly suffixing and agglutinating (see also Holmberg & Roberts 2013; Hawkins & Gilligan 1988). Hence, if Central Kurdish is shown to be a head-final language, then, according to Julien (2002), its verbal morphology is expected to logically and statistically contain suffixal morphology only. In the first place, by definition, complements in head-final languages appear to the left of their selecting heads, which suggests that there is leftward XP-movement which is not driven by case. Complements in Central Kurdish appear to the left of their selecting verbs, regardless of their category, DP or PP, as shown in (14).

(14)

Azad kitêb-êk bo Shîrîn de-nêr-êt.
Azad book-INDEF to Shirin IND-send.PRS-3SG
'Azad sends Shirin a book.'

Secondly, indirect objects have the same realization as directional PPs, which is consistent with the fact that indirect objects are PPs in Central Kurdish, as shown in (14) above. According to Julien (2002), in head-final languages, arguments are licensed inside VP. Arguments do not, in general, move out of VP to get assigned case. Instead, it is the VP and higher verbal projections that move to higher specifier positions, which implies that the arguments must be licensed inside VP, as she claims to be the case in Lezgian, Japanese, Turkish, and Hindi. And, in order for this to be possible, the indirect object must be realized as a PP (there is no need for case checking or licensing of the indirect object if it is PP) or as an inherently case-marked DP (typically dative), as in German, for

example. The fact that indirect objects in Central Kurdish are PPs (as shown in 14) and that arguments can be licensed inside VP might seem as additional supporting arguments to characterize Central Kurdish as a head-final language.

Thirdly, like other head-final languages such as Turkish and Japanese, Central Kurdish has nominal and adjectival predicates immediately in front of the copula. Thus, there is a tendency that the copula is perceived as a suffix on the predicate, as the following examples show.

(15)

Turkish (Kornfilt 1997:77)

(Ben) satıcı-y-im.

I seller-COP-1SG

‘I am a seller.’

Japanese (Tsujimura 1996:127)

Taroo-wa nihonjin-da.

Taroo-TOP Japanese-COP

‘Taroo is Japanese.’

Central Kurdish

min xwêndkar-im

I student-1SG

‘I am a student.’

ew kich-e zor jiwan-e.

That girl-DEM very beautiful-be.PRS.3SG

‘That girl is very beautiful.’

ewan xwêndkar bû-n.

They student be.PST-3PL

‘They were students.’

It is worth noting that the present copula ‘be’ in Central Kurdish is often phonologically zero and the verbal agreement markers function as the conjugated copula form (see also chapter two). This, however, does not mean that the copula is not present. Instead, like the Turkish and Japanese examples, nominal and adjectival predicates are immediately in

front of the copula. This is clearly manifest in the third example of Central Kurdish where the copula is in past tense and is preceded by the nominal predicate. In all the three languages exemplified above, it seems clear that the copula is combined with the phrase syntactically. It is thus the syntax that creates a morpheme sequence that may be taken to constitute a word.

Nevertheless, while Central Kurdish has some of the above properties of head-final languages, this is not enough to say that it is a rigid or consistent head-final language. For instance, Central Kurdish has prepositions rather than postposition, as can be seen in (14) above. Another phrase that is head-initial in the language is Ezafe Phrase, as can be seen in the following example in which the Ezafe morpheme *-i* precedes its complement *min* ‘I’ (see Karimi 2007 for an account of Ezafe construction in Central Kurdish).

- (16)
- | | |
|------------|-----|
| mał-i | min |
| house-EZ | I |
| ‘My house’ | |

This means that Central Kurdish is a mixed-head language rather than a consistently head-final language. And even though there is a correlation between head-final order and suffixation, even in consistent head-final languages, there are exceptions with regard to having suffixal morphology only (Holmberg and Roberts 2013).

Nevertheless, the different types of affixes seem to have different phonological and syntactic properties, which require different mechanisms for their derivation. This is indeed the case in Central Kurdish in which the verbal prefixes have quite different phonological /and syntactic characteristics from the verbal suffixes, as argued for in the rest of this section. A possibility is that prefixes are heads that are syntactically separate from the verb but (phonologically) cliticized to it (see also Cinque 1999: 70 for a discussion on the different sources of prefixes). In the first place, it is problematic to assume that the negative particle is actually a bound morpheme (see also section 2.4.1 for a description on the negation particle). For instance, the negative marker *ne-* is not a bound morpheme when used in the ‘neither...nor’ negation or in coordinated structure, as (17a) and (17b) respectively show.

(17)

- a. **ne** goşt de-xw-at, ne sewze.
 NEG meat IND-eat.PRS-3SG NEG vegetable
 ‘He doesn’t eat meat, nor does he eat vegetables.’
- b. ne Azad hat û ne Sara-ş rroîşt.
 NEG Azad come.PST and NEG Sara-CONJ go.PST
 ‘Neither did Azad come nor did Sara go.’

Even in conjunction constructions where one conjunct is positive and the other one is negative, the negation particle can occur without a host, as shown in (18) below.

(18)

- Mary kitêb-êk=î krrî beîam Peter na.
 Mary book-INDEF=3SG.CL buy.PST but Peter NEG
 ‘Mary bought a book but Peter didn’t.’

Moreover, the verbal prefixes, namely the negation particle and the mood markers, can separately form a phonological phrase with the verb. When added to the verb stem, different from the usual stress pattern of Central Kurdish which is final, they attract stress to themselves. In other words, stress placement becomes initial in such phonological phrases, while it is always final in phonological words. For example, in (19a) where neither the negative particle nor the indicative marker (*de-*) is used, the stress placement is final and the whole constituent can be seen as one prosodic word. However, in (19b) and (19c), the negation particle and the indicative marker attract the stress to themselves (the placement of stress is shown in boldface).¹¹

(19)

- a. **xward**-in=əm.
 eat.PST-3PL=1SG.CL
 ‘I ate them.’
- b. **ne**=m xward-in.
 NEG=1SG.CL eat.PST-3PL
 ‘I didn’t eat them.’

¹¹ Although stress is shown by the use of boldface letters for relevant vowels, it should be noted that stress is a property of syllables, not just vowels.

- c. **de=î** kîrr-im.
 IND=3SG.CL buy.PRS-1SG
 ‘I (will) buy it.’

The examples in (19b and 19c) can be considered as somehow two ‘words’ consisting of either the negation particle or the indicative marker plus the inflected verb. The motivation for such an assumption is based on phonological characteristics of verbal prefixes.

It is worth noting that these markers cannot occur together except in negative past progressive constructions, as shown in (20). When they occur together, the stress placement is on the negative particle, as shown below.

- (20)
- ne=m** de-xward-in.
 NEG-1SG.CL IND-eat.PST-3PL
 ‘I was not eating them.’

Yet another argument is related to negating adjectives, which can be done via the same negation markers *ne-* or *na-*. Different from when they negate verbs, these markers will not attract stress to themselves when they are prefixed to adjectives, as in the examples of (21) where the stress placement is shown in boldface letters.

- (21)
- ne-xosh** ‘sick’
 na-xosh ‘distasteful’

Thus, when *ne-* or *na-* is a derivational morpheme, the stress pattern of the word will remain the same, namely, final. However, when the negative particle is inflectional, it attracts stress to itself and the stress pattern within the verbal complex becomes initial. Such different phonological characteristics of verbal prefixes imply that their derivation will also be different from that of the suffixes, as will be explained in the next section.

3.4 Deriving the Verbal Complex in Central Kurdish

The fact that the verb in Central Kurdish has both prefixation and suffixation, and that both types of affixation have different phonological (and syntactic) characteristics, simply

means that the derivation of verbal complex includes two different operations. Julien (2002) argues that prefixation should not be derived by head-movement. This is because head-movement within an LCA-based syntactic model must be left-adjunction. Thus, if a lexical stem head-moves to attach to the left of a functional head, it will result in the functional head ending up as a suffix on the lexical stem, as we have seen with the derivation of verbal complex in Northern Saami in section 3.2.1.

Instead, prefixation can be derived in two possible ways. First, the prefix might originate in the complement position of the lexical element and then moves to the left of the lexical element via either head-movement or XP-movement. Julien (2002: 188) provides an example from Nadëb for such a derivation. In (22a), the verb *asoo*h ‘sit’ has a postpositional phrase *bxaahyó* ‘tree on’. By contrast, in (22b), the postposition has become a prefix on the verb whereas the nominal complement of the postposition is now the object of the verb and has moved to the front of the sentence since Nadëb is an OSV language.

(22)

Nadëb (Julien 2002: 188)

- a. Kalapéeé asoooh bxaah yó.
 child sit tree on
 ‘The child is sitting on the tree.’
- b. Bxaah kalapéeé y-asoooh.
 tree child on-sit
 ‘The child is sitting on the tree.’

As Julien (2002: 189) explains, (20b) is the result of the postposition head P^o having head-moved and left-adjointed to V^o so that a complex head P^o+V^o is formed. Thus, in order for this analysis to be possible, it must be the case that the PP in (22a) must be the complement of the verb; otherwise the incorporation operation would violate the Head Movement Constraint. When the postposition is incorporated, Spec-PP and Spec-VP are in the same minimal domain which allows the complement of the postposition to raise and become the structural object of the verb. Julien (2002) submits that whenever a lexical root has a prefix that does not belong to the functional domain of the lexical element, one

should investigate the possibility that the prefix originates inside the complement of the lexical element, as we have seen in (22a).

Applying such method of deriving prefixes on Central Kurdish would mean that the mood prefixes and the negation particle must originate in the complement position of lexical verbs. This is obviously an impossible assumption. The fact that these prefixes directly belong to the functional domain of the lexical verb makes it unsound to assume the possibility that they originate inside the complement of the verb. Besides, as will be argued in the next section, these prefixes occupy positions above TP. Hence, it is not likely that they originate in the complement position of the verb and head-move to pick up the verb.

The second possible way of deriving prefixes is that they can originate immediately to the left of the lexical element without any subsequent movement operation of any of the two elements. When a functional head is prefixed to a verb stem, the functional head and the verb stem represent syntactic heads that have not moved with respect to each other. That is, the prefix is simply the spell-out of a head that is in a higher position than the stem it combines with, but adjacent to it. Applied to the prefixes in Central Kurdish, both the negation particle and the mood markers would then be parts of the verbal word because they normally appear immediately in front of the verb and cannot be separated from the verb by phrasal constituents (though they can host pronominal clitics when overt DPs are replaced). We then have a complex word (e.g. negative marker plus the verb stem) which is not the outcome of any particular syntactic operation but just the consequence of the distributional properties of the morpheme string that makes up the word. They would make up a phonological word which is not a syntactic constituent.

It seems that the second possibility works here. The verbal prefixes can be seen as the spell-outs of heads that are in higher positions than the root verb, and as Julien (2002) assumes for prefixes of this kind, they combine with the root phonologically. This also supports an earlier assumption that the verbal prefixes have different phonological characteristics than the verbal suffixes in Central Kurdish.

There are seemingly two problems with the observation that the verbal complex in Central Kurdish contains prefixes in addition to suffixes. In the first place, if the prefixes are the spell-out of heads that are higher than the verb stem in the structure, how is it possible to

derive the verbal suffixes? There are a number of heads such as passive, aspect, and agreement that are spelled out as suffixes. Secondly, and most importantly, if the prefixes originate to the left of verb without any movement of any of the two elements (that is, either the prefix or the lexical element), how is it possible to derive the OV order and the verbal complex considering the fact that prefixation and suffixation seem to be two different operations?

With regard to suffixation, head movement is the right mechanism considering the fact that the verbal prefixes occupy positions higher than the suffixes in the structure, and that the verbal prefixes in Central Kurdish are spell-out heads that are higher than the verb. This actually means that the suffixes occupy positions lower than the TP. As stated above, whereas the prefixes are modals, and as such have sentential scope, the verbal suffixes in Central Kurdish are all exponents of functional categories that are closely associated with TP internal functional projections such as passive, aspect, or agreement. The next section argues for the position of each verbal affix and the derivation of the verbal complex via both verb head movement and remnant VP movement.

3.5 The Split TP

Similar to the pioneering work by Rizzi (1997) on splitting the peripheral C head into a number of functional projections such as Force, Focus, Topic, and Finiteness, there have been a number of studies (most notably Cinque 1999) on splitting the inflectional head Infl (Chomsky 1981) into several functional heads such as Tense, Aspect, Mood, and Agreement. However, contrary to Chomsky (1993), Chomsky (1995: ch. 4) argued against the assumption that agreement occupies the head of a specific agreement projection. This is because agreement features are considered uninterpretable. And, any head which consists of only uninterpretable features will be invisible at LF, the interface with semantics. Hence, Chomsky (1995: 355) suggested the elimination of agreement heads from UG on conceptual grounds (see section 4.4 for a discussion on agreement features within the minimalist program).

With regard to tense, aspect, passive and mood, they mostly occupy explicit functional projections since they are interpretable features. Accordingly, the various verbal inflectional affixes characterized so far can be argued to head specific projections within the split TP. In line with the antisymmetry of syntax (Kayne 1994), I propose a head-

initial analysis of the verbal complex structure of Central Kurdish. Assuming the basic schematic structure in (23) in which both the negation particle and the mood markers precede the verb stem while the suffixes include an agreement marker, a passive marker, a perfect aspect morpheme, it seems that head movement is the means for the verb stem to pick up its suffixes while the remnant phrasal movement is the means of deriving the right word order within the verbal complex in Central Kurdish.

As is argued throughout this study, the tense head does not contain a specific tense morpheme, and what are claimed to be ‘past’ and ‘present’ stems do not actually contain a tense feature. In line with Cinque (1999) and Julien (2002), I assume that the mood markers, which can be perceived as ‘grammatical mood’, are contained inside the T⁰ head. In other words, the tense head contains the modal prefixes of realis (indicative) or irrealis (subjunctive).

Agreement features, unlike other inflectional morphology, do not conform to the Mirror Principle (as observed by Julien (2002)). They actually do not form independent syntactic heads on their own because (as Chomsky 1995: ch. 4 argues) no head can be made up only of uninterpretable/unvalued features. However, I assume for now that they reside in the head of an agreement projection, namely AgrSP (see chapter four for the exact projection of agreement morphemes in Central Kurdish).

(23)

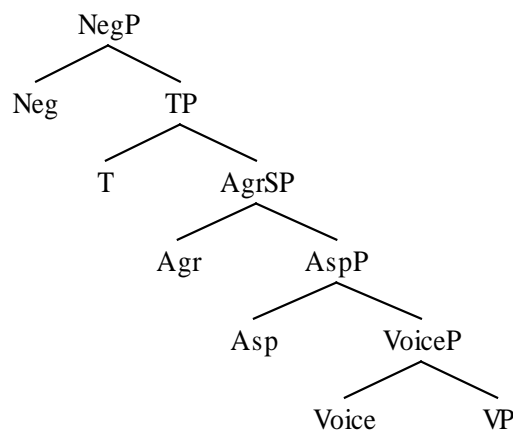

In the following subsections, each projection is argued for in more detail and its exact position with the split TP structure is characterized.

3.5.1 *Negation Projection*

Pollock (1989) argues that negation is a functional element which serves as a head. He argues that negation projects its own phrasal category and is represented as the head of NegP. Following Pollock (1989), Haegeman and Zanuttini (1991) and Haegeman (1995) adopt the idea that preverbal negative markers are X° heads of the functional category NegP while post-verbal adverb-like negatives appear as XP adjuncts. However, later, they separately propose that the adverb-like negators are specifiers of NegP. Hence, following Pollock, it seems plausible to suggest that the negative particle in Central Kurdish, which is preverbal, can be represented by the functional projection NegP. The head can be realized by the negative markers, with an empty operator in Spec-Neg to satisfy Haegeman's (1995) Neg Criterion.

The question is, then, how such a functional projection is represented in relation to VP and TP. Horn and Kato (2000) suggest that the position of NegP is parameterized with respect to TP, since negation can be generated TP internally or TP externally in different languages. In addition, Laka (1990, 1994) submits that negation is parameterized with respect to its position inside the TP projection, as is the case in English, or outside TP in the C-domain. Thus, it seems reasonable to conclude that the position of the negation projection can be either above or below TP.

Laka (1994) provides different pieces of evidence in order to determine the position of NegP with respect to TP. One piece of evidence is deletion in conjunction constructions where one conjunct is positive and the other one is negative. If it is possible to delete TP in the negative conjunct, it means that NegP is higher than TP. If it is impossible to delete TP, as is the case in English (shown in 24), it is the case that NegP is between TP and VP. In Central Kurdish, as shown in (25), it is possible to delete TP in such a conjunction construction, which suggests that the negation projection is higher than TP.

(24)

Mary bought a book but Peter didn't. (Laka 1994: 19-20)

*Mary bought a book but Peter not.

(25)

Mary	kitéb-ék=î	krî-Ø	belam	Peter	na.
Mary	book-INDEF=3SG.CL	buy.PST-3SG	but	Peter	NEG

In support of such a hypothesis is a second piece of evidence which comes from Negative Polarity Items (NPI). English shows a subject-object asymmetry with respect to NPI licensing, in that sentential negation does not license subject NPI, but it does license object NPI, as in (26). This means, according to Laka (1994), that negation is below TP in English. In contrast to English, Central Kurdish does not show a subject-object asymmetry with respect to NPI licensing. In other words, sentential negation licenses both subject and object NPI in Central Kurdish, as (27b) and (27c) demonstrate. (27a) establishes that *hiç kes* is an NPI in Central Kurdish, which is not allowed in affirmative contexts. This indeed explains the ungrammaticality of (27a).

(26)

- a. *Anybody didn't go to the party.
- b. John didn't know anybody at the party.

(27)

- a. *hiç kes Shîrîn=î nasî-Ø.
 Any person Shirin=3SG.CL know.PST-3SG
 ‘*Anybody knew Shirin.’
- b. hiç kes Shîrîn=î ne-nasî-Ø.
 Any person Shirin=3SG.CL NEG-know.PST-3SG
 ‘Nobody knew Shirin.’
- c. Shîrîn hiç kes=î ne-nasî-Ø.
 Shirin no person=3SG.CL NEG-know.PST-3SG
 ‘Shirin didn't know anybody.’

Hence, since Central Kurdish allows subject NPI, it should be the case that negation c-commands all arguments in TP, a fact which corroborates the first piece of evidence. Based on such evidence, I assume that the negation projection in Central Kurdish is high up in the IP-domain with the negation particle occupying the head of this projection. That is, the NegP is above TP in the language. The NegP projection is optional in the structure because when the sentence is positive, there is no morphological realization.

3.5.2 TP Projection

I assume that the tense head in Central Kurdish does not contain a specific tense morpheme. It contains, however, the mood morphemes, which are prefixes on the verb stem. Mood relates to how the speaker understands the event, how possible s/he thinks it is to occur, and if it occurs in our world (indicative) or in some other hypothetical world (subjunctive). Central Kurdish exhibits a clear mood distinction: indicative vs subjunctive. As argued in section 2.4, the mood prefixes convey both realis and irrealis modality. They are also in complementary distribution with each other. In particular, the realis prefix, which is the indicative marker *de-*, is in complementary distribution with the irrealis prefix, which includes both the subjunctive and imperative markers *bi-*.

Schütze (2004) argues that English finite clauses contain an inflectional head, which marks the property of mood (indicative, subjunctive, or imperative). He postulates a Mood Phrase (MoodP) projection between CP and TP. The head of this projection is the locus of modals and mood morphemes. In particular, it either contains a modal auxiliary such as *will/can/must* or a mood (indicative or subjunctive) morpheme. However, such morphemes are not considered to occupy the head of MoodP above TP, as Schütze (2004) argues for English. Instead, they are seen as a feature of the category T. Hence, alongside tense feature, the T head is considered to include mood features in Central Kurdish.¹² This is in fact, as stated above, in line with Cinque (1999) and Julien (2002) who submit that grammatical moods such as indicative and subjunctive can be components of T.

A good reason to associate mood morphemes with the T⁰ head is related to the conditions on the use of these markers. For example, the indicative marker *de-* is almost always associated with present tense, being used in the past only to indicate past progressive. This marker seems to be an indication of the present tense, and most speakers of the language distinguish present tense from the past via the use of this marker. This might be the reason why it should be called ‘non-past indicative marker’. Another argument that these mood markers occupy the same head, which may be the T⁰ head, is their complementary distribution, as observed above.

¹² Even if the mood markers were assumed to occupy a projection above TP in Central Kurdish, say MoodP, it would not pose a major problem for the derivation of verbal complex in the language, as will become clear in the text below.

In most literature on Central Kurdish (e.g. Fattah 1997), however, the indicative marker *de-* is considered to be an aspect marker.¹³ If this assumption is thought to be true, Central Kurdish then proves to be a language that definitely presents a hard puzzle in relation to the incorporation analysis of morphologically complex verbs, to the point where the derivation of the verbal complex by head movement will certainly prove impossible (see section 3.4). This is because aspect markers should occupy projections lower than TP (see Julien 2002: 41-48); and if this is the case, the subjunctive and imperative markers should occupy different projections, possibly higher than TP. Another problem is related to the perfect suffix *-û/w* (see section 3.5.3), which is thought to be the true aspect marker. It is not plausible to have one aspect marker, which is a prefix, and another, which is a suffix, especially as they are not cases of inner and outer aspect, as will become clear below.

Julien's investigation of 530 languages of different language families and geographical regions reveal that if both tense and aspect are affixal, aspect is always closer to the verb stem than the tense. Hence, the morpheme order in (28a) is possible whereas the one in (28b) should not occur.

- (28)
- a. Verb-Aspect-Tense
 - b. *Verb-Tense-Aspect

Besides, as explained in the previous section, it is assumed that prefixation is not derived by head movement. It is the result of a sequence of syntactic functional categories and a lexical head that are phonologically pronounced as one word. In some languages, the sequence of [_{TP} T [_{AspP} Asp [_{VP} V...]]] is pronounced as one word. This implies that the order in (29) below should not occur. Therefore, assuming that the verbal prefix *de-* in Central Kurdish is an aspect marker occupying the head of AspP is incorrect.

- (29) *Aspect-Tense-Verb

As argued in the previous section, the negation particle occupies a projection above TP. In most cases, negation does not occur with the modal prefixes in Central Kurdish. In

¹³ In fact, there is a somewhat similar marker in almost all Iranian languages. Among the few analyses of this marker (cf. Fattah 1997), it is considered as an aspect marker occupying the head of (imperfective) AspP below TP.

particular, the negation does not co-occur with the subjunctive and imperative markers, as shown by the ungrammaticality of (30a) and (30b). Nevertheless, the indicative marker does co-occur with the negation, particularly in past tense clauses, as shown in (30c).

(30)

- a. *ne bi-rroîşt-im-aye,
 NEG SUB-go.PST-1SG-be.PST.IRR
 ‘If I had not gone,’
- b. *ne bi-rro-n!
 NEG IMP-go.PRS-3PL
 ‘Don’t you go!’
- c. ne-de rroîşt-im.
 NEG-IND go.PST-1SG
 ‘I was not going (away).’

I assume that the negation particle can be merged (phonologically) with the imperative marker *bi-* and the non-past indicative marker *de-*. Thus, what seems like different realizations of the negative particle are in fact such phonological incorporation. The prohibitive prefix *me-*, I assume, is the result of the negative morpheme *ne-* plus the imperative marker *bi-*, derived by nasal assimilation. This claim is also supported by phonological characteristics of both morphemes. The prohibitive prefix in (31) conveys both the functions and meanings of the imperative (realized as *bi-* in Central Kurdish) and negation (realized in Central Kurdish as *ne-*).

(31)

- me-rro!
 NEG-go.PRS
 ‘Don’t go!’

Another instance of such phonological merge is the use of the negation morpheme with the indicative marker *de-*. The combination of the negation morpheme *ne-* plus the indicative marker will result in the negative marker *na-*, as exemplified in (32) below.

(32)

na-rro-m.

NEG-go.PRS-1SG

‘I don’t go.’

It is not clear why this process of phonological merge does not happen in the past. One possible explanation is that the indicative marker *de-* is always used in the present, whereas in the past it is only used to convey imperfective meaning. Thus, if merged with the negative marker *ne-* to form *na-*, it would lead to the loss of the imperfective meaning in the past.

To take stock, a distinguishing characteristic of verbal prefixes is that they are modal whereas the suffixes include aspectual and agreement morphemes. Hence, both negation and mood prefixes occupy inside and above TP while the verbal suffixes occupy positions lower than TP.

3.5.3 *Aspect Projection*

Like tense and mood, aspect is also considered an interpretable feature. There is no conceptual objection to positing that aspect can be realized as a specific functional head. In many languages, the presence of an aspect head has been postulated (e.g. Laka (1990) for Spanish and Basque and Alexiadou (1997) for Greek). Although it has been argued throughout this study that there is no tense morpheme in Central Kurdish, T⁰ carries the mood markers. It thus remains to be seen whether there is evidence for positing the existence of an aspect head within the split TP.

As argued in chapter two, the only realized aspect morpheme in Central Kurdish is the suffixed perfect marker *-û/w*. It is particularly suffixed to the past stem to form present perfect aspect. Simple aspect is not phonologically realized. As can be seen in (33a), the perfect aspect morpheme follows the past stem of the verb in the surface order and precedes the agreement marker. It is worth noting that in some varieties of Central Kurdish the whole verbal complex is followed by the present auxiliary ‘be’, realized as *-e*. Thus, instead of (33a), (33b) is the possibility in such varieties.

(33)

- a. rroîşt-û-m.
go.PST-PERF-1SG
'I have gone.'

- b. rroîşt-û-m-e.
go.PST-PERF-1SG-be.PRS.3SG
'I have gone.'

The copula 'be' functions as the auxiliary verb here and carries the tense of the whole complex clause. Although the past stem of the verb is used, the whole complex actually conveys present perfect. In other words, the present tense auxiliary, which is overt in (33b) and covert in (33a), represents the tense of the whole complex. Besides, when the verb is transitive, the verbal agreement markers, which can be considered as the conjugated form of the auxiliary 'be', are used, as shown in (34). It should be noted that the subject agreement marker is the pronominal clitic since a past transitive verb is used (see chapter four for a detailed discussion on agreement).

(34)

- xward-û=man-e.
eat.PST-PERF-1PL.CL-be.PRS
'We have eaten (it).'

Postulating a functional projection for aspect below TP seems the correct way of representing the aspect morpheme in Central Kurdish. A schematic structure for (33a) will look like (35), in which the aspect head and the agreement features are affixed to the verb via head movement of the verb. The irrelevant projections are left out.

(35)

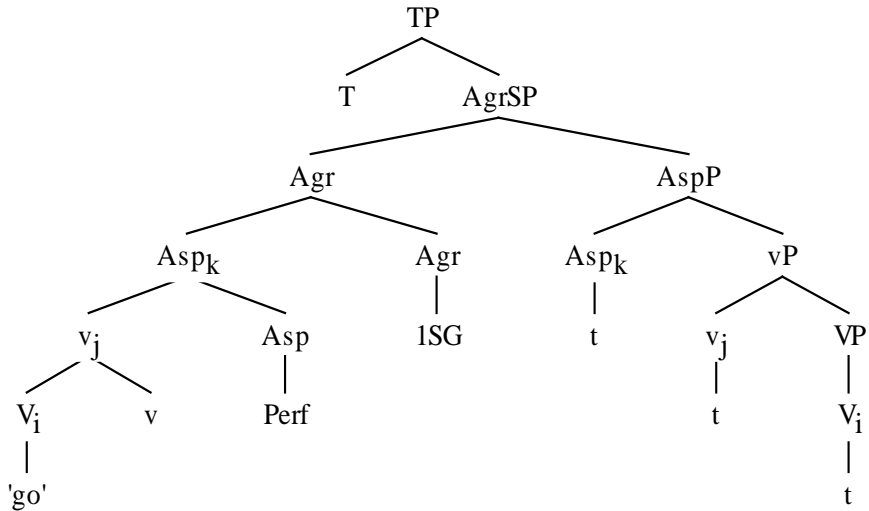

What is remarkable about perfect aspect in the language is that in the past tense no specific morpheme is used. Instead, the past tense of auxiliary ‘be’ is used with the past stem of the verb. Hence, the past tense version of (33a) is as in (36). It is not clear (at this stage) why there is such a difference with regard to perfect aspect in the language, and it is not pursued any further here.

(36)

roîşt-bû-m.
go.PST-be.PST-1SG
‘I had gone.’

3.5.4 *Passive Projection*

Voice morphemes are also located within the split TP. Due to its affix like character, the passive voice in Central Kurdish can be considered to head its own projection in the syntax. The passive morpheme is always adjacent to the verb stem. I will assume that the passive morpheme heads a Voice Phrase situated immediately above vP.

A distinguishing characteristic of the passive morpheme in the language is that there are two different morphemes: one for the present tense passive, which is *-rê*, and another for the past tense, which is *-ra*. This is perhaps related to the fact that the present stem of the verb is always used in the passive formation. As a result, it seems that the passive morpheme conveys the tense of the verbal complex. This actually has led some

researchers (e.g. Fattah 1997) to assume that the passive morpheme is only $-r$ and that the $-ê$ or $-a$ are added to indicate present and past tense respectively. However, as argued in section 2.5.3, this assumption is not correct on the grounds that there is no (phonologically realized) tense morpheme in Central Kurdish. If such markers were the indications of tense, they could have been used in other verb forms beside passive. The fact that they are only used in passive is a good argument for considering them as part of the passive morpheme.

In fact, some good evidence for considering the passive morpheme to be either $-rê$ for present and $-ra$ for past is provided by the passive perfect aspect. As can be seen in (37), the passive stem does not change with the change in the tense of the whole clause. This shows that the tense is in the auxiliary ‘be’ (see also section 2.5.2 for a discussion on aspect).

(37)

- a. kuj-ra-û-m.
kill.PRS-PASS.PST-PERF-1SG
‘I have been killed.’
- b. kuj-ra-bû-m.
kill.PRS-PASS.PST-be.PST-1SG
‘I had been killed.’

It seems that the reason for using only the present stem of the verb in the formation of the passive is that past stems in Central Kurdish are passive in nature and unable to theta-mark subjects in their specifiers (see section 4.5 for a detailed discussion of this topic). As a result, since the present stem of the verb is used for both past and present tense, there are two different passive morphemes for past and present respectively. A schematic structure for a sentence like that in (37a) will look like the following.

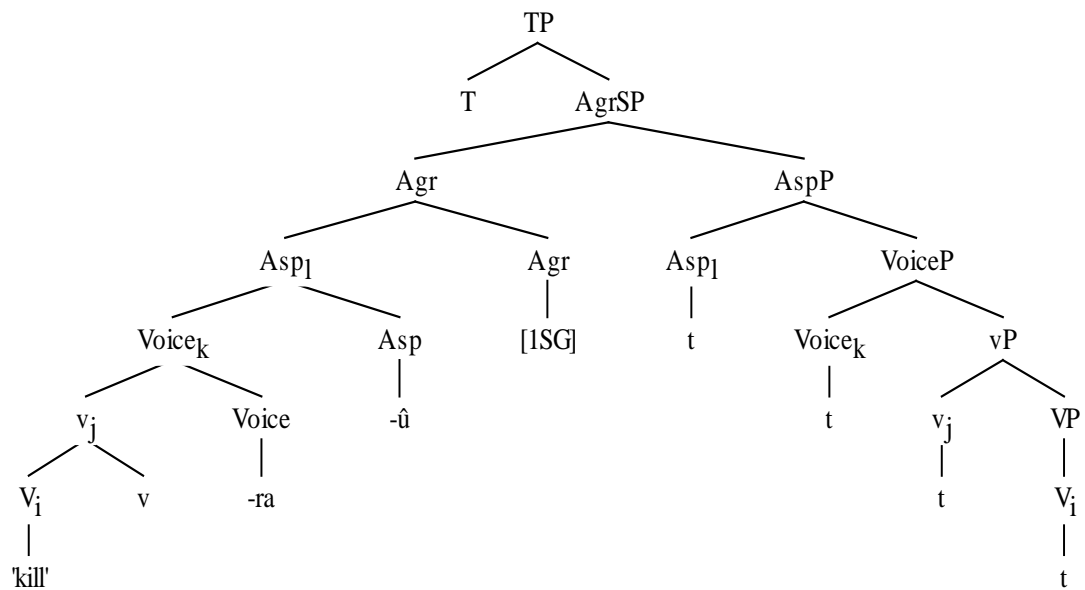

3.6 Argument Positions

The present work is carried out in the spirit of the constructionist approach even though many of the specific claims of that theory will not be relevant here (see also chapter one for a brief discussion). Contrary to the lexicalist approach in which the lexical verb determines the argument structure of the clause, the constructionist approach considers the verb to be composed of smaller components (referring to subevents) and the structure around the verb plays a main role in the thematic and argument structure. This constructionist approach is mainly adopted here although the information about the verb in the lexicon plays a role as well. The essential problem for both lexicalist and non-lexicalist approaches is, nevertheless, the derivation of the hierarchical order of the arguments (this topic is not pursued in this thesis) (see also Harley (to appear); Harley (1995); Folli & Harley (to appear), among others, for a detailed discussion on the syntax of argument structure). The inadequacies and problems with the theta-theory of Government and Binding Theory led many researchers (e.g. Hale and Keyser 1993; Kratzer 1996; Larson 1988) to come up with alternative analyses and solutions with regard to the argument structure. Remarkably, the general answer was that verbal

predicates are made up of at least two projections. This can be called the little *v* hypothesis.

Although the motivation behind proposing little *v* hypothesis and the proposal by Hale and Keyser (1993, 2002) to argument structure are discussed in chapter five, it is important at this point to indicate the positions of the external and internal argument within the verbal complex in Central Kurdish. Arguing with the structures for unergative, causative/inchoative alternating verbs, and locatum verbs, Hale and Keyser (1993, 2002) submit that the agent (external) argument occurs in the specifier of VP whereas inner arguments occur inside the VP (complements of the verb). This is in line with the ‘VP-shell’ analysis of Larson (1988), which was developed and adopted by Chomsky (1995) as the *v*P framework. The subject of transitive verbs is merged in the specifier of a little *v*. As the examples in (39) show, the surface ordering of elements in Central Kurdish clause is as in (40).

(39)

a.	ew	perrtûk	de-kirr-êt.
	He	book	IND-buy.PRS-3SG
	‘He buys/is buying books.’		

b.	ew	perrtûk	na-kirr-êt.
	he	book	NEG-buy.PRS-3SG
	‘He doesn’t buy/is not buying books.’		

(40)

Subject-Object-NEG/Mood-V-AGR

It follows from the LCA (Kayne 1994) that the underlying word order of the languages is VO, and that OV order is derived by leftward movement of the object to a specifier position above the highest position of the verb (see section 3.4 above). Thus, adopting the antisymmetric theory, it is the case that the underlying word order is VO in Central Kurdish. When the verb complement is a DP or a PP, however, the surface order is OV. This means that the object must move out of the VP. Evidence in favor of VO word order is provided by the post-verbal position of CP arguments. When the complement of the verb is a clause (CP), the word order is actually SVO, as demonstrated in (41) below. Given the LCA, this would be because CP objects do not move, unlike DP and PP objects.

(41)

min de-zan-im ke ew mamosta-(y)e.
I IND-know.PRS-1SG that he teacher-be.PRS.3SG
'I know that he is a teacher.'

The ordering in (40) suggests an important implication for the derivation of the verbal complex in Central Kurdish; that is, the arguments occupy positions high up in the structure, notably higher than negation projection. The final suffix on the verb is the subject agreement marker, which suggests that the verb has moved to the subject licensing head. At the same time, the object precedes the verbal inflections and the verb but follows the subject DP in the surface order. This suggests that the subject has moved even higher than the subject licensing position, which, in the case of Central Kurdish, should be higher than NegP (see the structure in (23)). The object is also higher than the NegP because it always precedes the negation particle. Julien (2002) also submits that in head-final languages, smaller or larger constituents might move from their lower positions within the clause to specifier positions within the CP domain (see Rizzi 1997), in particular to the focus position Spec-FocP and the topic position Spec-TopP. She assumes that the trigger for such movement is focus or topic features present on the moved constituents.

Karimi (2010: 704) argues for topicalized subjects in Central Kurdish, especially in the past tense. He believes that since the EPP remains on C^0 , the 'dative DP simultaneously raises to [Spec, TP] and [Spec, CP] to satisfy the EPP and EDGE/TOPIC features respectively'. While I argue for the surface position of the subject to be higher than TP, c-commanding the subject-agreement markers, I do not relate such DP movement to the subject DP being inherently dative or the person-case constraint effect, as Karimi assumes. It should be noted, however, that the theta-marking position of the subject in the past and present tense is assumed to be different in the language and most probably in other Kurdish dialects and Iranian languages (see chapter four for a discussion on this topic).

For his assumption that 'dative agents' are positioned within CP, Karimi (2010: 705) draws evidence from the passive of the double object construction. This is exemplified in (42) below.

(42)

- a. min diyarî-eke-an de-de-m be Azad.
I gift-DEF-PL IND-give.PRS-1SG to Azad
'I will give the gifts to Azad.'
- b. diyarî-eke-an de-d-rê-(ê)n be Azad.
gift-DEF-PL IND-give.PRS-PASS.PRS-3PL to Azad
'The gifts will be given to Azad.'
- c. Azad diyarî-eke-an=î pe=de-d-rê-(ê)n.
Azad gift-DEF-PL=3SG.CL to=IND-give.PRS-PASS.PRS-3PL
'Azad will be given the gifts.'

In (42b), which is the passive sentence of (42a), the direct object has raised to the subject position. According to Karimi (2010: 705), the direct object will be assigned 'nominative case' if it becomes the subject of a passive sentence. This might also explain the agreement with the passivized verb. In (42c), the indirect object has raised to become the subject of the passive sentence. Karimi submits that the indirect object has already been assigned 'the dative case' from the preposition prior to the movement to the subject position. The direct object, being in the Spec-TP, shows agreement with the verb. The indirect object, having an inherent dative case, thus raises to the Spec-TopP.

Karimi (2010) believes that only in the case of (42c) does the subject get a topicalized reading. In other words, the raised indirect object in (42c), which functions as the subject of the sentence, is in Spec-TopP. As a result, it is doubled by a 'dative clitic'. Thus, the A-bar position of the subject is only reserved for a 'dative' DP. The subject (nominative subject in Karimi's terms) in other cases (e.g. in (42a) and (42b)) occupy Spec-TP, according to Karimi (2010: 706).

As is manifest, Karimi's account is case-driven, which is not favored in this study (see also section 4.7.2 for a discussion on ditransitive construction and its ergative agreement pattern). Besides, as is evident from the morpheme order in (40), it is the case that arguments in Central Kurdish must occupy positions that are higher than the verbal functional categories. Hence, assuming that the 'nominative' subject (as in (42a)) is in Spec-TP is indeed improbable and problematic for the derivation of verbal complex in the language.

Being a pro-drop language, the subject DP in Central Kurdish is usually not pronounced in the sentence. This is because it is retrievable from the agreement features present on the verb. When pronounced, however, it is mostly for contrastive emphasis. Then, this might indicate that the subject DP moves out to a specific subject position which is higher than TP. Following Cardinaletti (2004), who argues for two subject positions within Infl domain, it seems that the subject position in Central Kurdish is within the Infl domain, not CP domain. This is because quantified subjects, which are non-topical, occur in what looks like the canonical subject position in the language. In other words, if subjects always occupied Spec-TopP (a position within CP domain), it would predict that those subjects that are clearly non-topical, which include quantified subjects such as *hemu kes* ‘everybody’ or *her kes* ‘anybody’, should not occur in that position as well. As shown in (43), the quantified subject *hemu kes* ‘everybody’ does occupy the canonical subject position in the language, much like other ordinary subjects.

(43)

hemu	kes	de-twan-êt	ferî	mele	bi-b-êt.
All	person	IND-can.PRS-3SG	learn	swim	SUB-be.PRS-3SG
‘Everybody can learn to swim.’					

Whether it is within the Infl or CP domain, it is manifest that the subject DP occupies a position higher than the verbal functional categories. The exact surface position of the subject DP needs further future research. For now, it is assumed that it occupies the specifier of a specific subject position distinct from Spec-TP, perhaps SubjP in Cardinaletti (2004)’s terms.

With regard to the OV order, I submit that the remnant phrasal movement is responsible. Following Baker (1985, 1988), I assume that the verb head-moves to pick up its inflectional suffixes, which may include passive, perfect aspect, or agreement morphemes. The final suffix is always the agreement marker and this is where the verb stops its movement. The head movement of the verb to *v* and then other functional heads paves the way for VP movement to take place. VP in this case is a ‘remnant category’, in that it contains only a subset of the material it contained at an earlier stage of the derivation. This movement of VP, which typically contains the object and possible VP-adjuncts is thus referred to as remnant movement. The remnant VP movement brings

about the right OV word order. When the complement of the verb is a CP, such remnant movement does not happen (see Biberauer *et al.* 2014).

As explained in section 3.3, the verbal prefixes have different characteristics from the suffixes. In fact, the verbal prefixes in Central Kurdish seem to function as independent morphemes and thus do not enter the derivation with the verb stem. As Julien (2002: 225) argues, prefixes do not normally form a constituent in any non-phonological sense with the root that they attach to (see sections 3.3 & 3.4).

As shown in the schematic structure in (44), the verb movement to pick up its inflectional morphemes, which include only the suffixes of passive, aspect, and agreement morphemes, paves the way for the remnant phrasal movement of VP to take place. In other words, once the verb stem head-moves to pick up the suffixes one by one, the remnant movement takes place in order to bring about the OV order. This remnant VP movement is, I assume, to the Spec-NegP, the highest verbal functional domain. The position of the subject is assumed, for now, to be the Spec-SubjP for expository reasons (see also the next section for some recalcitrant residues concerning this derivation).

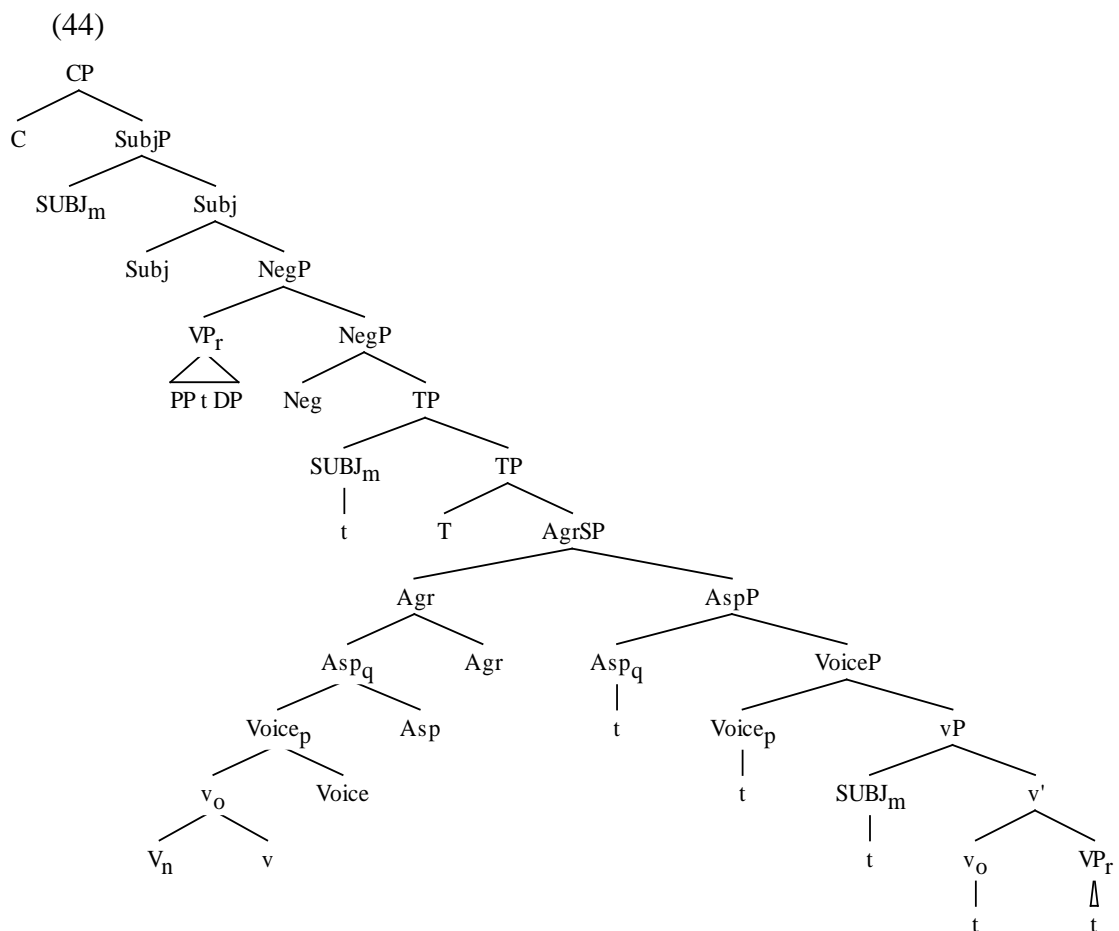

3.7 Recalcitrant Residues

Although the structure in (44) above accounts, to a large extent, for the derivation of verbal inflections in Central Kurdish, there are a number of structures which *prima facie* pose problems. Firstly, in addition to the position of the subject DP, the derivation of OV order is not clear-cut. Particularly, it is assumed that the remnant VP movement lands in the Spec-NegP. The question is, then, what happens if the sentence is positive, that is, a clausal structure in which the negative morpheme is absent. In fact, not all projections (or morphemes) are always present. For example, the mood morphemes which reside in the head of TP are almost always absent in the past tense. Hence, the answer to the question is that the VP remnant movement essentially targets the highest verbal functional category available within the Infl domain (the Infl being split into a number of projections). This means that the remnant phrasal movement targets the Spec-TP if other higher functional projections such as NegP are not available, and this is indeed the case in positive clauses.

Another residual problem is related to the agreement pattern in the language, especially the different agreement patterns depending on the tense. As briefly discussed in section 2.5.4, the verbal agreement markers are used to show subject agreement in the present tense and past intransitive clauses, as shown in (45a) and (45b) respectively, whereas pronominal clitics show agreement with the subject in past transitive clauses, as in (45c).

(45)

- a. (min) de-rro-m.
I IND-go.PRS-1SG
'I go. / I am going.'
- b. (ême) honrawe de-nus-în.
we poem IND-write.PRS-1PL
'We write poems.'
- c. Aram bra-eke=î bînî-Ø.
Aram brother-DEF=3SG.CL see.PST-3SG
'Aram saw his brother.'

As can be seen in (45c), the position of the clitic is different from the verbal agreement markers. Whereas the pronominal clitic is enclitic on the second available constituent

within the verbal predicate, the verbal agreement markers are always suffixed to the verb stem (as shown in (45a) and (45b)). Besides, these agreement markers can also cross-reference the object when the object is not overt.

It is not plausible to assume that the unvalued ϕ -features of T are represented by two different inflectional morphemes. The different agreement pattern in the past and the present tense reveals the different clausal structure in Central Kurdish associated with the present and past tense. In other words, the syntax of past tense is evidently different from that of the present tense. The structure in (44) thus needs to be adapted to reflect the difference in the clausal structure and agreement pattern of the language. This is accomplished in the next chapter in which the syntax of agreement in Central Kurdish is discussed in detail.

Another prevalent structure in the language is complex predicates, also known as the light verb construction. Such structures are formed by the use of a light verb, which is mostly the verb *kirdin* ‘to do’, plus a non-verbal element, which is mostly a nominal. This is exemplified in (46).

(46)

minał-eke-an	şerr	de-ke-n.
child-DEF-PL	fight	IND-do.PRS-3PL

‘The children are quarrelling.’

It remains to be established whether the derivation and structure proposed in (44) for simple predicates works for complex predicates such as the sentence in (46) above. The morphosyntactic characteristics of complex predicates in general and the syntax of verbal inflections within such structure in Central Kurdish are discussed in detail in chapter five. It will be demonstrated that the analysis proposed in this chapter and the agreement pattern that will be shown in the next chapter can be applied to complex predicates without much difficulty.

3.8 Summary

Central Kurdish is definitely a language that presents a hard puzzle in relation to the incorporation analysis of morphologically complex verbs. This is mainly because its verbal complex contains both prefixal and suffixal morphology. The fact that there are

different methods for deriving either type of affixes makes it challenging to derive verbal complex in the language. It was observed that prefixes are phonologically different from suffixes, supporting the analysis according to which they are derived in different ways. Thus, I have argued that prefixes in Central Kurdish do not directly enter the derivation with the verb syntactically and that they occupy heads that are higher than the verb and the suffixes in the structure. As for the suffixes, head movement, which creates a complex out of a lexical element and one or more elements from the functional domain of that lexical element, is the means of their derivation. Finally, remnant VP-movement is responsible for bringing about the right word order of the arguments and verb in the verbal domain in Central Kurdish.

Chapter 4. Agreement Marking

4.1 Introduction

Understanding the agreement (and case) pattern and the interplay between the pronominal clitics and verbal agreement markers within the verbal complex is crucial to the understanding of a number of syntactic operations within the clause structure of Central Kurdish. The syntax of agreement and marking in the language presents an intriguing phenomenon, and it helps in the identification of a number of functional heads in the clausal structure. Since previous research has not adequately accounted for the syntax of verbal agreement markers (and concatenations with pronominal clitics) and how they can be accounted for within the clausal structure, this chapter attempts to present possible explanations and analysis for these inflectional morphemes. In particular, it demonstrates how current linguistic theory can account for the complex system of agreement and marking, case, and word order of verbal complex in Central Kurdish, which has split ergativity and a system of pronominal clitics as exponents of case and agreement in the language.¹⁴

The chapter will proceed as follows: in the next section a background description is given of the phenomenon of split ergativity in some Kurdish dialects. Section 4.3 provides the essential descriptive background on the agreement and marking pattern in the language. At first, a number of characteristics and distinctions are given to determine the status of the bound pronominals in the language, of which one set is identified as affixes and the other as clitics. Then, the alignment pattern of the language is described. Moreover, in a subsection a number of situations are referred to in which clitic-affix concatenation occurs and necessary explanations are provided. Section 4.4 provides the theoretical background for the syntactic analysis of agreement markers in the language. In section 4.5, I provide a number of arguments in favor of the distinction between the past and present verb stem in the language, which is the basis for the analysis provided in section 4.6. Section 4.7 provides an explanation for the status of the pronominal clitics in the language. Section 4.8 refers to a number of other ergative-like constructions whose characteristics and

¹⁴ In fact, not all researchers (cf. Bynon 1980; Jügel 2009) agree that Central Kurdish has ergativity.

analysis attest the analysis provided in the preceding section. Finally, a brief summary of the findings is given in the last section.

4.2 Split-Ergativity

The term ‘ergative’ is widely used to describe an agreement/case pattern in which the subject of an intransitive clause is marked similarly to the direct object of a transitive clause, and differently from the transitive subject (Dixon 1994). Ergative marking system, which is estimated to be used by only one quarter of world’s languages (Dixon 1994: 10), is usually contrasted with the accusative system (an example being English), which is far more common. Different types of ergative languages based on notions of transitivity or whether ergativity is morphological or syntactic are referred to in literature. It is not, however, the scope of this thesis to establish the different typologies of ergative languages (see, for example, Legate 2012, 2008; Woolford 2015; Bittner & Hale 1996, among many others).

A significant characteristic of all ergative languages is that they are never ergative in all aspects of their syntax and morphology, but instead use a combination of ergative and accusative properties. That is, depending on the grammatical context, an ergative language might use ergative case marking system for some constructions and accusative case marking for other constructions. The term in widespread use for such a system is split-ergative. As Holmberg (2004) explains, most Indo-Iranian languages, including most Iranian languages, have a split-ergative case and agreement marking system. In this system, depending on the tense and/or the aspect, the subject and the object have different case marking and the verb can agree with either of the arguments. In particular, the present tense (or imperfective aspect) has an accusative alignment in which the subject is in direct case (as it is generally known as such within Iranian linguistics) while the object is oblique, and the verb agrees with the subject.¹⁵ The past tense (or perfective aspect) has an ergative alignment in which the subject is in oblique case while the object has a direct case, and the verb agrees with the object. An example of such system is Northern Kurdish, also known as Kurmanji, as shown in (1). The agreement is shown in boldface letters.

¹⁵ Instead of referring to or using direct case, some researchers use nominative or dative (Karimi 2010, 2013). Central Kurdish does not distinguish any morphological case. Thus, since there is no ergative case marking on the nominal in the language (as well as in other Kurdish dialects), oblique is the cover term used for ergative.

(1) *Northern Kurdish*

a. **Ez** **te** **di-bîn-im.**
I-NOM you-OBL IND-see-1SG
'I see you.'

b. **Min** **tu** **dît-i.**
I-OBL you-NOM saw-2SG
'I saw you.'

(Matras 1992)

Baker and Atlamaz (in progress) argue that tense-based split ergativity in Adiyaman Kurmanji, a dialect of Northern Kurdish, is best accounted for in a theory in which case can be assigned by agreement. In other words, the crossed agreement pattern is deeply intertwined with the crossed case pattern in the language. It is then the case that related Iranian and specifically Kurdish languages can have the same agreement system as Northern Kurdish but may lack a case system. Hence, although Central Kurdish does not have a similar crossed case pattern at least not overtly, as there is no morphological case on its arguments, it is clearly evident that the crossed agreement pattern is almost parallel. In particular, the agreement pattern in Northern Kurdish, which was exemplified in (1), can also be attested in Central Kurdish. (2) shows present tense sentences in which the verb agrees with the subject in both the transitive and intransitive. (3) shows past tense sentences. In (3a) the intransitive verb agrees with the subject, but in (3b) the transitive verb does not agree with the subject but rather with the object.¹⁶

(2)

a. **minal-ek(e)-an** **de-rro-n** **bo** **xwêdinge.**
child-DEF-PL IND-go.PRS-3PL to school
'The children are going to school.'

b. **ew** **hêwaş** **nan** **de-xw-at.**
He slowly bread IND-eat.PRS-3SG
'He eats food slowly.'

¹⁶ Karimi (2010) explains that in Central Kurdish object-verb agreement in the past happens only if the object is third person (agreement in number) or if it is *pro* (agreement in number and person). A past clause has an overt first or second pronoun object if and if the verb bears default (3rd singular) agreement. However, Karimi (2013) has a slightly different perspective. He states that many speakers do not allow agreement with an overt object in the past, even in number (see also section 4.3.2).

(3)

- a. ke **ême** rroîşt-**în**, **êwe** geîşt-**in**.
When we leave.PST-1PL you arrive.PST-2PL
‘When we left, you arrived.’
- b. min **perdax-eke=m** şikand-**Ø**.
I glass-DEF-1SG.CL break.PST-3SG
‘I broke the glass.’

Other dialects of Kurdish with the same crossed agreement pattern include Hawrami.¹⁷ As shown in (4), in the present tense in Hawrami, in both transitive and intransitive clauses, the subject agrees with the verb via a suffix on the verb stem. However, in the past tense, as shown in (5), the intransitive verb agrees with the subject (5a), whereas in the transitive clause (5b) the verb agrees with the object.

(4)

- a. **Ahmał** mæ-ram-**o**.
Ahmad IND-run-3SG
‘Ahmad runs.’
- b. **pyâ-ke** æsp-ækæ-i mæ-win-**â**.
people-the-PL horse-the-ACC IND-see-3PL
‘The people see the horse.’

(5)

- a. **žiwa** kæwt-**æ**.
Zhiwa fell-3SG.F
‘Zhiwa (f) fell.’
- b. **æsp-e=m** di-**e**.
horse-PL=1SG saw-3PL
‘I saw horses.’

(Holmberg and Odden 2014)

¹⁷ Central Kurdish has somewhat a similar system as Hawrami. However, unlike Hawrami, which can have either direct or oblique case marking on object DP, Central Kurdish has no case marking at all on any DP or pronouns. However, in some varieties of the language such as the Mukri variety, there are distinctions on the independent pronouns based on their case or oblique case marker on object DP.

It thus is manifest that the three dialects, to a large extent, have similar crossed agreement pattern.

Following the works of Dorleijn (1996), Karimi (2013) and Baker and Atlamaz (in progress), I propose a phase-based theory to account for the case-and-agreement patterns in Iranian languages. The crucial point and launching pad for this proposal lies in the difference between present and past verb stems. Like other Iranian languages, the past stem in Central Kurdish is strikingly different from the present stem. In particular, it is claimed (Dorleijn 1996; Karimi 2013; Baker and Atlamaz (in progress)) that past stems are ‘defective’, which might be due to a residue of their origins as passive-like participles in Old Iranian (see Haig 2008; Jügel 2009).

Hence, building on the proposal by Mendívil Giró (2012) and Baker and Atlamaz (in progress), the essence of the discussion throughout this chapter is that past and present clauses have different clausal structures. This evidently results in the different agreement pattern (split-ergative pattern) that is manifest in the Central Kurdish. Furthermore, it is the aim of this chapter to mainly account for the syntax of the agreement markers within the verbal complex of Central Kurdish. Particularly, it is important to show the role that both sets of agreement markers play within the verbal complex especially with regard to agreement (and case) in the language. Moreover, it is essential to elucidate how ergativity in Iranian languages, particularly in Central Kurdish, is related to past tense, as claimed by Dorleijn (1996), Karimi (2013), and Baker and Atlamaz (in progress), among others; that is, whether tense conditions the phenomenon of split-ergativity in the language.

4.3 Agreement in Central Kurdish

Central Kurdish has one set of independent pronouns and two sets of bound pronominals of which one set is affixes and the other clitics, as shown in Table 2.1, which is repeated in the following. These two sets of bound pronominals are referred to in this thesis as verbal agreement markers and pronominal clitics. Verbal agreement markers are used to show subject and object verb agreement; whereas pronominal clitics are used to double the subject in the past (show agreement with the subject), show object (direct and indirect) marking in the present, but only if the overt object is dropped, and show possession in nominal structures.

Table 2.1: Independent and bound pronominals in Central Kurdish¹⁸

#	Person	Independent Pronouns	Pronominal Clitics	Verbal Agreement Markers	
				Set 1 (Present)	Set 2 (Past)
SG	1	min	=(i)m	-(i)m	-(i)m
	2	to	=(i)t	-î(t) / (Imp) -Ø / -e	-î(t)
	3	ew	=î	-a(t) / -ê(t) / -Ø	-Ø
PL	1	ême	=man	-în	-în
	2	êwe	=tan	-(i)n	-(i)n
	3	ewan	=yan	-(i)n	-(i)n

Within grammatical theory, it is usually acknowledged that it is difficult to distinguish between clitics and affixes. Phonologically they are very similar as they are both phonologically attached to other independent words. In addition, the distinction might not even be very helpful with regard to their syntactic analysis. Everett (1996) argues that the distinction between clitics and affixes is entirely superficial, as might seem to be the case in Central Kurdish. It is nevertheless crucial for the analysis proposed in this chapter.

The exact nature and characteristics of clitics are difficult to pinpoint. This is because clitics seem to be at the crossroads of morphology and syntax. In some respects, they seem to behave like affixes since they are attached to other words; while in certain other respects, they behave as independent words. Many grammatical categories such as

¹⁸ In the Mukri variety of Central Kurdish, the independent pronouns can be divided into two sets of strong and weak pronouns, as shown below. This distinction, however, does not have direct influence on the analysis proposed in this chapter.

		<u>Strong</u>	<u>Weak</u>
SG	1	emin	min
	2	eto	to
	3	ew/ ewî (obl)	wi (obl)
PL	1	eme	me
	2	engo/êwe	=ngo
	3	ewan	wan

auxiliary verbs, negation, determiners, can be realized as clitics. Still, some general characteristics of clitics can distinguish them from affixes.

In the first place, clitics have a fixed position in the clause whereas affixes do not impose such demands with regard to their position. For example, many languages have second position clitics, in what is often called Wackernagel position.¹⁹ Secondly, clitics do not care about the grammatical category of the word they attach to. That is, they co-occur with hosts of different categories (nouns, verbs, prepositions). What they usually adhere to is the position of the constituent they attach to. Affixes, on the other hand, usually select a particular category to attach to, and do not care in which position that category is syntactically. As Zwicky and Pullum (1983: 503) explain, ‘clitics can exhibit a low degree of selection with respect to their hosts, while affixes exhibit a high degree of selection with respect to their stems’. Thus, verbal agreement markers in Central Kurdish are always attached to verbs and hence the derivation of their names; while the clitic status of the pronominal clitics derives primarily from their ability to attach to a host of different grammatical category such as pre-verbal particles, negation particles, mood markers, verb stem, etc.

Another distinction is that clitics attach to material already containing clitics or inflectional suffixes, but affixes cannot attach to materials already containing clitics (though there are exceptions). For instance, there can be a head that can host both affix and clitic but always in the following orders.

- Head-Affix-Affix (possible)
- Head-Clitic-Clitic (possible)
- Head-Affix-Clitic (possible)
- Head-Clitic-Affix (not possible)

Thus, in Central Kurdish, two clitics can occur side by side, as in (6), whereas a verbal agreement marker can never attach to a verb already containing one. However, as will be

¹⁹ Wackernagel’s Law is a general rule, mostly for Indo-European languages, which states that particles and clitic elements occupy a position in the clause after the first accented constituent. In other words, such elements occupy the second position in a clause; hence this second position in a clause is sometimes referred to as ‘the Wackernagel position’.

seen in section 4.3.3, there are cases in which the clitic intervenes between the verb stem and the affix rendering the order of Head-Clitic-Affix possible.

(6)

kiç-eke=m=yan	maç	kird-Ø.
girl-DEF=1SG.POSS.CL=3PL.CL	kiss	do.PST-3SG

‘They kissed my daughter.’

It should be noted however that many researchers (e.g. MacKenzie 1961; McCarus 1958, 2009; Fattah 1997) on Kurdish language do not make the distinction between affixes and pronominal clitics, and label both dependent forms as clitics or as affixes. For example, Mahmoud (1994) call these morphemes ‘subject and object clitic’ whereas MacKenzie (1961) refers to the clitics as personal pronoun suffixes and suffixed pronouns. Nonetheless, since verbal agreement markers are always suffixed to the right edge of verb stem and have a lot of characteristics of affixes, they will be labelled as affixes rather than clitics. Throughout this paper, the term clitic will be exclusively reserved for pronominal clitics showing indirect manifestation of oblique case in the language (see section 4.7).

In the following subsections 4.3.1 and 4.3.2, I will sketch out the syntax of alignment pattern (accusative & ergative) in the language.

4.3.1 *Nominative-Accusative Alignment*

Verbal agreement markers are typically the subject-verb agreement morphemes.²⁰ They are consistently restricted to the right edge of the verb stem. With regard to their distribution, such agreement morphemes are always used in the verbal structure. In the present tense, and for all intransitive and transitive verbs, verbs agree in number and person with the subject via an agreement morpheme suffixed on the verb stem. The verbal agreement markers license subject pro-drop in present tense (transitive and intransitive). The examples in (2), repeated here as (7), demonstrate subject-verb agreement in present intransitive and transitive clauses.

²⁰ Verbal agreement markers are called nominative affixes by Karimi (2010). I disagree with such terminology, however.

(7)

- a. minal-ek(e)-an de-rro-n bo xwêdinge.
child-DEF-PL IND-go.PRS-3PL to school
'The children are going to school.'
- b. ew hêwaş nan de-xw-at.
He slowly bread IND-eat.PRS-3SG
'He eats food slowly.'

In present transitive clauses, pronominal clitics are used to cross-reference the direct object only when the object is *pro*. If the object is present, however, it is impossible to use such clitics. In (8a), since an independent pronoun *min* 'I', which functions as the direct object, is used, there is no need for the use of a pronominal clitic. A verbal agreement marker *-at* is suffixed to the verb to show agreement in number and person with the subject *Azad*. As Karimi (2010) states, an independent pronoun in the object position receives the contrastive stress. When the object is not a full DP or an independent pronominal, it will be thus represented by a relevant pronominal clitic, as shown in (8b). A relevant verbal agreement marker is still used to show agreement with the subject.

(8)

- a. Azad min de-ba-(a)t bo zanko.
Azad I IND-take.PRS-3SG to university
'Azad is taking/takes me to the university.'
- b. Azad de=m-be-at bo zanko.
Azad IND=1SG.CL-take.PRS-3SG to university
'Azad is taking/takes me to the university.'

In fact, the complementary distribution between independent pronoun and dependent pronominal clitic can also be established with regard to indirect objects, as shown in (9).

(9)

- a. Azad name-(y)êk bo min de-nêr-êt.
Azad letter-INDEF to I IND-send.PRS-3SG
'Azad sends a letter to me.'

- b. Azad name-(y)êk=im bo de-nêr-êt.
 Azad letter-INDEF-1SG.CL to IND-send.PRS-3SG
 ‘Azad sends a letter to me.’

As can be seen in (8b) and (9b), the clitic does not function as an agreement morpheme; it simply seems to function as the direct object in (8b) and indirect object in (9b). Karimi (2010) calls pronominal clitics in Central Kurdish ‘dative clitic’. However, I disagree with this view. Agreeing with Holmberg (2004), who believes that pronominal clitics in Hawrami realize ‘oblique case’ for the subject, such clitics also realize oblique case in Central Kurdish albeit indirectly. Even Karimi (2013) himself states that they are indirect manifestation of oblique case. The examples in (8b) and (9b) are in fact a clear evidence for the claim that pronominal clitics are indirect manifestation of oblique case in the language (more on the analysis of pronominal enclitics in section 4.7).

Unlike in Northern Kurdish in which personal pronouns fall into two categories of direct and oblique, the personal pronouns in Central Kurdish only take an invariant form and hence do not display any case distinction.²¹ Accordingly, since Central Kurdish does not have morphological case marking on arguments or personal pronouns, the agreement pattern should be used to determine the alignment pattern of the language. As can be seen in the above examples, it is clear that the subject of intransitive clauses and the subject of transitive clauses are grouped together, represented by the verbal agreement markers, whereas the object is clearly different, represented by pronominal clitics (particularly when the DP object is *pro*). Therefore, the alignment pattern in the present tense is evidently accusative. What remains is the alignment pattern in the past, which is the focus of the next subsection.

4.3.2 Ergative Alignment

The past tense agreement pattern (and case system if there was any) of Central Kurdish clearly follows the ergative pattern. As is distinctive of an ergative system, the subject of an intransitive clause and the object of a transitive clause group together in terms of agreement and (or) case, to the exclusion of the subject of a transitive clause. As Haig (2004, 2008) and MacKenzie (1961) explain, constructions containing a transitive verb

²¹ See footnote 17 and 18.

in the past tense have a different syntax than those with a present tense. The same verbal agreement markers that are used in the present tense to show subject-verb agreement are used in the past to show object-verb agreement. As explained above, the object-verb agreement is the default third person singular, which is phonologically not realized.²² Another way of explaining the object agreement in the past is that it only happens when the object is third person (agreement in number). However, the full object-verb agreement (agreement in number and person) is manifested when the object DP is *pro*. Object-agreement is shown in (10).

(10)

- a. min name-(e)k(e)-an=im nard-∅.
 I letter-DEF-PL=1SG.CL send.PST-3SG
 ‘I sent the letters.’
- b. nard-in=im.
 send.PST-3PL=1SG.CL
 ‘I sent them.’

In (10a) the object-verb agreement is default; whereas in (10b), the object is *pro* which prompts the full agreement in person and number. In fact, for third person singular object agreement, no morpho-phonological realization is available. For third person plural, *-in* is used (see Table 2.1). A piece of evidence for object agreement in Central Kurdish is that both dependent forms (clitics and affixes) cannot have the same function. That is, it not plausible to assume, for example, that subject verb agreement is carried out by two different morphemes in different tenses (see also section 4.6 for the analysis of agreement). Besides, indirect objects in the past tense are referenced by a relevant verbal agreement marker. In (11) below, the complement of the preposition is conveyed by an agreement marker, which is suffixed on the verb stem. The subject is clearly doubled by a relevant pronominal clitic. It is worth noting that indirect objects in Central Kurdish are always prepositional phrases, and that the object of the preposition can also be conveyed

²² In the Mukri variety of Central Kurdish, object-verb agreement is more obvious and not always default third person singular. Thus, instead of (10a), it is possible in this variety to state the following sentence in which the object agrees in person and number with the verb via a relevant verbal agreement marker *-in* instead of 3rd person singular *-∅*.

min name-(e)k(e)-an=im nard-in.
 I letter-DEF-PL=1SG.CL send.PST-3PL
 ‘I sent the letters.’

by a clitic attached directly to the preposition. For expository reasons, only the version in (11) is given.

(11)

xelk lê=yan de-kirrî-m.
people from=3PL.CL IND-buy.PST-1SG
'People were buying from me.'

The subject of past intransitive verb is marked interestingly by the same verbal agreement markers that are used to mark the object in past transitive shown in (10). Thus, in (12), the subject agrees with the intransitive verb via a relevant agreement marker.

(12)

ke ême roîşt-în, êwe geîşt-in.
When we leave.PST-1PL you arrive.PST-2PL
'When we left, you arrived.'

Clearly then, the subject of intransitive verb and the object of transitive verb in the past group together in terms of agreement, namely, both are marked by verbal agreement markers.

With regard to the subject of a past transitive verb, it is always doubled by a relevant pronominal clitic (the placement of the pronominal clitics is discussed in the next subsection). The clitic realizes oblique case for the subject albeit indirectly. In (10a), even though the subject is realized by a full form, it is still obligatorily doubled by a pronominal clitic =*im*. The clitic can also license subject pro-drop, as shown in (10b). It is thus manifest that the subject of a past transitive verb cannot be grouped with the subject of intransitive verb and the object of transitive verb. In other words, the agreement pattern in the past tense is ergative.

4.3.3 *Clitic Placement*

A distinctive feature of pronominal clitics is that they have no invariable position within the verbal complex. That is, their position in the clause structure changes depending on the available elements within the domain of verbal structure, such as the available prefixes on the verb stem or the presence or absence of direct and indirect objects. For instance,

in a past ditransitive construction, the clitic, which doubles the subject, will be enclitic on the direct object, as shown in (13a). If the direct object is *pro* and represented by a verbal agreement marker, then the clitic will attach to the indirect object, as in (13b). In case of a past monotransitive construction in which the object is *pro* (as in 13c and 13d), the pronominal clitic will attach to the right of the leftmost constituent of the VP (see Haig 2004), as shown in the following hierarchy of landing sites:

Preverbal particles > Negation > Mood Markers > Verb Stem

(13)

- a. name-(e)k(e)-an=î bo ewan ne-nard-Ø.
 letter-DEF-PL=3SG.CL to they NEG-send.PST-3SG
 ‘He did not send the letters to them.’
- b. bo ewan=î ne-nard-in.
 to they=3SG.CL NEG-send.PST-3PL
 ‘He did not send them to them.’
- c. ne=î nard-in.
 NEG=3SG.CL send.PST-3PL
 ‘He did not send them.’
- d. nard-in=î.
 send.PST-3PL=3SG.CL
 ‘He sent them.’

In addition to Haig (2004)’s rule for the placement of clitics, other rules include those of Friend (1985) and McCarus (1958), which state that clitics attach to the first non-subject constituent of the clause. Moreover, Holmberg (2004) states a rule for Hawrami clitic placement that it is ‘enclitic on the leftmost (non-adjunct) constituent in the VP.’ Hence, a better rule for the placement pattern of pronominal clitics in Central Kurdish would be to state that they attach to the first non-subject and non-adjunct constituent of the clause. The placement of pronominal clitics should not be considered as an example of Wackernagel’s Law in the language.²³ This is because subject DPs, temporal adverbials,

²³ See footnote 19 for a definition of Wackernagel’s Law.

and prepositional phrases can all precede the object and still do not host the clitic (Karimi 2010), as demonstrated in (14a, b, c) respectively.

(14)

- a. Azad name-(e)ke=î nard-Ø.
 Azad letter-DEF=3SG.CL send.PST-3SG
 ‘Azad sent the letter.’
- b. Azad dwênê name-(e)ke=î nard-Ø.
 Azad yesterday letter-DEF=3SG.CL send.PST-3SG
 ‘Yesterday, Azad sent the letter.’
- c. Azad bo Amrika name-(e)ke=î nard-Ø.
 Azad to America letter-DEF=3SG.CL send.PST-3SG
 ‘Azad sent the letter to America.’

Still, the placement pattern of the clitic within the verbal complex can be seen as the second-position phenomenon obeying Haig (2004)’s rule mentioned above. Besides, when both sets of bound pronominals are used to cross-reference the subject and the object DPs in the past and present transitive clauses, regardless of the mirror principle, the pronominal clitic seems to always precede the verbal agreement suffix in the phrase. This is because, as explained above, the clitic attaches to the leftmost (first) constituent within the verbal complex. This constituent, if overt DP objects are not present, is either preverbal particles (see section 5.4.2.1 for a discussion on preverbal particles), the negation particle, or mood prefixes, as demonstrated in (15), respectively.

(15)

- a. heɫ=yan de-gir-im.
 PREV=3PL.CL IND-catch.PRS-1SG
 ‘I will keep them.’
- b. ne=man bird-in.
 NEG=1PL.CL take.PST-3PL
 ‘We didn’t take them.’
- c. de=yan be-m.
 IND=3PL.CL take.PRS-1SG
 ‘I will take them.’

4.3.4 *Clitic-Affix Concatenation*

The clitic-affix concatenation seems to only occur in past transitive structures where the overt DP object is *pro*, represented by a relevant verbal agreement marker, and the verb stem is the only constituent in the structure and has no prefixes such as the negation particle, the mood markers, or preverbal particles. In this respect, the verbal agreement marker in (16a), which shows object-verb agreement, can in fact licence object pro-drop, as in (16b). However, since the verbal agreement marker in this case is phonologically null, it seems that only a pronominal clitic is used.

(16)

- a. pîtza-(e)ke=m xward-Ø.
pizza-DEF=1SG.CL eat.PST-3SG
'I ate the pizza.'
- b. xward=im-Ø.
eat.PST=1SG.CL-3SG
'I ate it'

Clitic-affix concatenation in one verbal structure becomes more evident if the object is any other person and number except third person singular, as demonstrated in (17).

(17)

- a. xward=im-in.
eat.PST=1SG.CL-3PL
'I ate them.'
- b. xward=man-in.
eat.PST=1PL.CL-3PL
'We ate them.'
- c. kûşt=yan-im.
kill.PST=3PL.CL-1SG
'They killed me.'

In the examples of (17) the pronominal clitic and the verbal agreement marker have been used side by side making it difficult to distinguish them. The complication is mainly due

to the fact that the verbal predicate is the only element in those sentences and consists of only a verb stem without any prefixes. Thus, if the subject is doubled by a pronominal clitic in the past transitive structure and a verbal agreement marker shows object-verb agreement, where do these agreement morphemes end up since there is only one slot available for both of them; namely the verb stem? We might expect the answer to such a question to be that since the verbal agreement marker is a suffix and the pronominal clitic is clitic, the suffix should be on the verb and the clitic would be outside the suffix. However, as can be seen in (17), this is not the case. The clitic attaches to the verb stem and the agreement marker follows it. Therefore, it seems that this clitic attachment to the verb stem is the only instance in which something comes between the verb stem and the verbal agreement marker. As previously noted, an explanation for such clitic placement on the verb stem when it is the only element in the verbal structure is that pronominal clitics in verbal structure follow a morpho-phonological second position rule rather than being second-position clitics. Another possible explanation is that the object agreement marker is not an affix but rather a clitic pronoun. This is, however, not consistent with the fact that such agreement markers have many characteristics of affixes rather than clitics. These are some facts which indicate that the order is a morpho-phonological matter. This issue needs further investigation and will not be pursued any further in this study.

Nonetheless, in one variety of Central Kurdish, namely Garmiani, such second position of clitic does not occur. For example, instead of having (17c), in the Garmiani variety there is (18) in which the pronominal clitic follows the verbal agreement marker.

(18)

kûşt-im=yan.

kill.PST-1SG=3PL.CL

‘They killed me.’

Even in standard Central Kurdish, there are cases, particularly when the subject is first singular person, in which the clitic and the suffix can exchange their position without having any structural or meaning effect. This, however, might be due to the fact that the first singular person is the same for both sets of formatives, namely, *-(i)m*. Besides, this phenomenon seems to be phonological and subject to variation among speakers. This phenomenon is exemplified in (19) below.

(19)

- a. kûşt=im-in.
kill.PST=1SG.CL-3PL
'I killed them.'

- b. kûşt-in=im.
kill.PST-3PL=1SG.CL
'I killed them.'

4.4 Agreement in Minimalism

In chapter three, it was, to a large extent, manifest that the inflectional morphemes within the verbal complex of Central Kurdish could rather successfully be accounted for by using the syntactic approach for word formation and following the Mirror Principle (Baker 1985, 1988). Nevertheless, as Holmberg and Roberts (2013) state, not all inflectional morphology follows the Mirror Principle. One example of such inflectional category is agreement, which does not easily fit into the relatively firm framework that syntactic analyses offer. Although Chomsky (1993) put forth the idea that clauses include a subject agreement head and an object agreement head located in fixed positions universally, it has become evident recently that languages actually display variations with respect to the positioning of agreement markers.

It is widely assumed now (Speas 1991; Spencer 1997; Holmberg and Platzack 1995; Julien 2002; Fuß 2005; Chomsky 2000, 2001a, 2001b; Holmberg and Roberts 2013) that agreement features do not form heads of their own and that they are parasitic on other functional heads. In contrast to most other inflectional morphemes, agreement morphemes do not have fixed positions. They have a fixed position within a language but this is not dictated by UG. Thus, agreement morphemes can appear in a number of different positions within the clause structure. Holmberg and Roberts (2013) relate the nonconformity of agreement morphemes to the Mirror Principle to the assumption that 'agreement features do not form autonomous syntactic head positions on their own' (Holmberg and Roberts 2013: 126). Since they are uninterpretable features, they need other functional heads to be associated with, as argued by Chomsky (1995: Ch. 4).

Chomsky (1993, 1995: Ch. 4) states that syntactic agreement is formed by using a specifier-head relation between an argument, which is the agreement controller, and the predicate, which is the agreement target. The relation is referred to as checking: the argument checks the agreement features (ϕ -features) on the agreeing head. Agreement checking is dependent upon argument movement (A-movement) to the specifier of a functional head, which also attracts the inflected verb. According to Chomsky (1993), the functional head that enters the agreement checking relation with an argument via A-movement is either AgrS (for the subject) or AgrO (for the object), while based on Chomsky (1995: Ch. 4), the functional head is either T (for the subject) or v (for the object). Based on this assumption, argument movement is triggered by ‘strong’ categorical features which are part of the set of formal features of a given functional head and must be eliminated prior to Spell-out.

Chomsky (2000, 2001a, 2001b) revises the minimalist analysis of agreement and proposes a rather different model of the computational system and its basic components. The revised model has been widely adopted within the minimalist theory. In the first place, the existence of ‘strong’ non-interpretable categorical features such as [$*D$] or [$*V$] on T/ v is not responsible for checking the set of non-interpretable/non-valued ϕ -features located in T/ v . Instead, the ϕ -set itself triggers the valuing or checking operation. Secondly, there is no necessary A-movement of DP argument into the specifier of the relevant functional head. That is, feature checking does not need argument movement. Rather, the set of uninterpretable ϕ -features located in T/ v may access the interpretable ϕ -set of an argument which stays in situ. This operation is called Agree, which ‘establishes a relation (agreement, Case checking) between an LI [lexical item] α and a feature F in some restricted search space (its *domain*)’ (Chomsky 2000: 101). Any feature set that starts an Agree operation is referred to as a *probe*. A probe establishes a relation with another set of ‘matching’ features called the *goal*. In case of agreement, the unvalued ϕ -features in T/ v functions as a probe that seeks a set of matching interpretable ϕ -features (the goal) with which it can establish agreement. As in Chomsky (1993, 1995), it is largely believed that ϕ -features are only interpretable on DPs and uninterpretable on T/ v . Chomsky (2000) submits that once the set of unvalued ϕ -features establishes an Agree relation with the ϕ -set of a nominal argument, the value of the nominal argument will be assigned to the unvalued ϕ -set on T/ v . The uninterpretable ϕ -set on T/ v will then be marked for deletion, which can be postponed until the derivation reaches Spell-out to

allow the features to be phonetically spelled out. The main characteristics of probe and goal can be summarised as follows (Chomsky 2000: 122):

(20)

Matching is a relation that holds of a probe P and a goal G. Not every matching pair induces Agree. To do so, G must (at least) be in the domain D(P) of P and satisfy locality conditions. The simplest assumptions for the probe-goal system are:

- a. Matching is feature identity.
- b. D(P) is the sister of P.
- c. Locality reduces to closest c-command.

Although the importance of structural Case is noticeably reduced in this framework of Agree, there is still, as Chomsky states, a close relation between agreement (ϕ -feature checking) and structural Case. Since case is not included in the feature set of the probes T/v, it cannot trigger checking operations. This is because Agree entails feature matching between probe and goal. In particular, in order for agreement and case-marking to be established, 'Probe and Goal must both be active' (Chomsky 2001a: 4). And, for any constituent (be it a probe or a goal) to be active it must contain uninterpretable features. Thus, any Agree relation means the deletion of uninterpretable features on both the probe and the goal. The uninterpretable feature on the goal is Case. That is, it seems that Agree contains two sub-operations: one in which the unvalued ϕ -features (person/number) on the probe will be valued (and later deleted), and another in which the unvalued case feature [u-Case] on the goal will be valued (and later deleted). It is worth noting that the [u-Case] on a goal can only be valued by a probe with a complete set of ϕ -features.

Another important aspect of the Agree operation is related to movement. As Chomsky (2000: 123) posits, a constituent with a valued (deleted) case feature cannot undergo further movement and is 'frozen in place.' Accordingly, it is necessary that the following statement be added to the characteristics of probe and goal mechanism stated in (20).

(21)

The operations Agree and Move require a goal that is both local and active (Chomsky 2000: 123).

Hence, syntactic movement is mainly dependent on a previously established Agree relation. In order for a phrase to move, there must be a trigger. It is usually assumed that functional heads might have an EPP feature. For example, it is generally supposed that T, in at least some languages, hosts an EPP feature, which requires the subject to move to its specifier. Other functional heads that might have an EPP feature include C (for the purpose of wh-movement) and v (for the purpose of object shift). Chomsky (2000: 135) revises the operation Move, which includes both operations of Agree and Merge, as in the following:

(22)

Move of β , targeting α , consists of the following three mechanisms:

- a. A probe P in the label L of α locates the closest matching G in its domain.
- b. A feature G' of the label containing G selects a phrase β as a candidate for 'pied-piping'.
- c. β is merged to a category K.

Chomsky (2000, 2001a) formulates a new concept of locality, which is very relevant to the topic of this chapter and the analysis of agreement proposed for Central Kurdish. This new concept is called *phase*, which states that syntactic computation proceeds via certain derivational stages. It is assumed that any sentence has two phases, which are CP and v P. Neither TP nor VP constitutes a phase. Once completely derived, a phase is spelled-out and interpreted, after which it is not accessible to any syntactic operation. Thus, the head of a phase cannot trigger operations once it is completed. At the same time, higher heads cannot trigger operations inside a completed (spelled-out) phase, although they affect the phase as a whole, for instance by moving it. Chomsky (2000: 107) states these conditions as in (23) and (24).

(23)

The head of a phase is 'inert' after the phase is completed, triggering no further operations.

(24)

Phase Impenetrability Condition (PIC)

In phase α with head H, the domain of H is not accessible to operations outside α , only H and its edge are accessible to such operations.

Henceforth, PIC means that movement of a constituent out of a phase is only possible if the constituent has first moved to the left edge of the phase. What this implies is that target of phrasal movement is the edge of every phase (CP or ν P).

To take stock, it is significant to notice that agreement determines case (Chomsky 2000, 2001). Central Kurdish does not have a morphological case system, and because case is not the topic of this thesis, the focus will particularly be on the agreement pattern in the language. Still, following Baker (2013) and Baker and Atlamaz (in progress), it is important to see how agreement can actually determine the case pattern in a language. Any case-driven approach (e.g. Bobaljik 2008; Preminger 2011) is rejected for Central Kurdish and not adopted in this thesis.

While Central Kurdish does not particularly have a morphological case system, the agreement-driven approach adopted in this chapter is essential in determining the agreement pattern of the language and the nature of pronominal clitics. For example, as Holmberg (2004) submits, in Hawrami, a subject DP does not show case. Instead, case is evident in constructions where pronominal clitics are used. In the past tense, the subject is doubled by a clitic, which, as Holmberg believes, realizes oblique case for the subject.

As stated above, only CP and ν P constitute phases. Since the focus is on the verbal domain, it is important to notice that only the ν P in transitive and unergative verbs constitute phases whereas the ν P in passives and unaccusative verbs are not phases. The fundamental part of Baker and Atlamaz's (in progress) and Karimi's (2013) analysis depends largely on the idea that past stems are defective. Particularly, Baker and Atlamaz (in progress) claim that ν in past tense clause structure is not a phase head, whereas ν in the present tense is a phase head. As Haig (2004) also discusses, the syntax of past tense is different from that of the present tense in Central Kurdish (and in other Kurdish dialects). In the next section, it is shown how the use of either past verb stem or present verb stem, not some other inflections or functional heads, determines the syntax of past or present clauses in Central Kurdish and in some other Kurdish dialects.

4.5 Past vs Present

The major difference between clauses with past and present verb stems in Kurdish (and some other Iranian) languages, as claimed by Karimi (2010, 2013); Baker and Atlamaz (in progress) among others, is related to the status of the v node. In other words, the split ergative pattern (crossed agreement-and-case pattern) is dependent on the phasal status of v node. In particular, as mentioned above, it is assumed that v in the present tense clauses is a phase head whereas v in the past clause is not. This difference will play a major role in the analysis of clause structure in general and agreement pattern in particular (see also section 4.6).

As argued in section 2.2.2, the terms ‘past’ versus ‘present’ verb stems do not convincingly capture the difference between them. These terms might even lead one to incorrectly believe that verb stems in Central Kurdish contain tense features. In fact, the difference between past and present stems in Central Kurdish and possibly other Iranian languages is not so much a semantic distinction concerning time reference as it is a formal-morphological distinction centered on what form of the verb stem is used. Therefore, the difference between past and present clauses in Central Kurdish (and also in other Iranian languages) should not be related to T or other TAM-related functional heads such as aspect or mood. This appropriately supports an earlier assumption that the T^0 head in Central Kurdish does not contain agreement features but rather is occupied by mood morphemes (see also section 3.5.2). This is because if T^0 contains agreement features, it would not be possible to show the difference between the structure in the past and present clauses (see the next section).

Hence, the agreement alignment (and case assignment) in Central Kurdish and other Kurdish dialects is significantly dependent on the verb stem, not other inflectional morphemes within the verbal complex (Haig 2008; Karimi 2010, 2013; Baker and Atlamaz (in progress)). As clearly demonstrated in chapters two and three, a number of inflectional morphemes can be used with the verb stem. Such inflections include, among others, mood prefixes (the indicative marker *de-* and the subjunctive *bi-*), negation particle, and verbal agreement markers. However, none of these inflections determine which agreement alignment be used. For example, the prefix *de-* can be used with the past stem to give past imperfective (as exemplified in 25a) or with the present stem to give simple indicative (habitual) meaning (as in 25b). Accordingly, mood or aspect has

nothing to do with agreement (and ergative) pattern in Kurdish, as it does in some other languages like Hindi.

(25)

- a. pîtza=m de-xward-Ø.
 pizza=1SG.CL IND-eat.PST-3SG
 ‘I was eating pizza.’
- b. beyanîan hêlke de-xo-m.
 mornings egg IND-eat.PRS-1SG
 ‘In the mornings, I eat eggs.’

The same is also true for the subjunctive marker (*bi-*). It can be used with the present stem to give a present subjunctive or with the past stem to give a past subjunctive. This is shown in (26a) and (26b) respectively.

(26)

- a. eger bi-rro-m,
 if SUB-go.PRS-1SG
 ‘If I go...’
- b. eger bi-rroîşt-im-aye,
 if SUB-go.PST-1SG-be.PST.IRR
 ‘If I had gone,’

As is the case in Northern Kurdish, then it is obviously the verb stem that controls the ergative alignment (split-ergative pattern) in the clause structure of Central Kurdish. This is in contrast to other Indo-Iranian languages like Hindi or Pashto in which aspect (perfective or imperfective) determines ergativity in the language (see Roberts 2000). Aspect, represented and realized only by the suffix *û-*, does not determine the split-ergative pattern in Central Kurdish.

Following Dorleijn (1996), Baker and Atlamaz (in progress: 13) claim that the reason why *v* in the past has this unusual property is because the past stem is ‘intrinsically passive’. They also provide a number of arguments to prove that it is synchronically true in Northern Kurdish and other Kurdish dialects (Haig 2008; Karimi 2010, 2013). Moreover, Jügel (2009: 142) states that past stems in almost all of the New Iranian

languages, of which Kurdish languages are part, are derived from the Old Iranian past participle. Once this nominal form (past participle) was introduced into the verbal paradigm, it led to ‘an untypical system of case assignment to the grammatical relations (such as A, O, S).’

Some of the bits of evidence that Baker and Atlamaz (in progress) provide to determine the passive nature of past stems do not apply to Central Kurdish, though. Specifically, in Central Kurdish, the participle form that is semantically and syntactically parallel to adjectives has a past passive suffix and perfect aspect suffix, as shown in (27b). This is in contrast to Northern Kurdish in which the participle is made out of the past stem plus the suffix *-i*, which can easily be used to modify a noun, as shown in (28).

(27) *Central Kurdish*

- | | | |
|----|--------------------|------------------------|
| a. | kurr-î | qoz |
| | boy-EZ | handsome |
| | ‘(a) handsome boy’ | |
| b. | kurr-î | kuj-ra-û |
| | boy-EZ | kill.PRS-PASS.PST-PERF |
| | ‘(a) killed boy’ | |

(28) *Northern Kurdish*

- | | | |
|----|--|---------------|
| a. | beq-ê | kesk |
| | frog-EZ | green |
| | ‘(the) green frog’ | |
| b. | beq-ê | kuşt-i |
| | frog-EZ | kill.PST-PART |
| | ‘the killed frog’ (the frog is dead, passive interpretation) | |

(Baker and Atlamaz in progress: 13)

Clearly, then, the fact that Central Kurdish, unlike Northern Kurdish, has a passive suffix, does not support the idea that past stem is inherently passive in the language.²⁴ Moreover,

²⁴ Northern Kurdish does not have a morphological passive. That is, there is no passive morpheme. Instead, passive is expressed periphrastically through the use of the verb ‘come’ plus the nominalized form of the transitive verb.

as can be seen in (27b), passive in Central Kurdish is formed via the use of present stem rather than past stem, which is the case in Northern Kurdish, as can be seen in (28b). However, one conclusion to take away from (27b) is that the present stem is not inherently passive; this is why a past passive morpheme can be added. Furthermore, being inherently passive in nature, past stems are never used in the formation of passive in Central Kurdish. In other words, one cannot passivize a passive.

Nevertheless, there is an argument from nominalization which can be used to determine the passive nature of the past stem. As Baker and Atlamaz (in progress: 14) explain for Northern Kurdish, the past stem but not the present stem is used in the formation of nominalization in Central Kurdish. Nominalization is formed by adding the (infinitive) suffix *-in* to the past stem, as shown in (29).

(29)

kuşt-in-î	gyandar-eke	xrap	bû.
kill.PST-NOML-EZ	animal-DEF	bad	be.PST

‘The killing of the animal was bad.’

It is manifest that this nominalization is intrinsically passive in that it allows the theme argument (*gyandar-eke* ‘the animal’) of the verb to be expressed like a possessor in the larger nominal. The Ezafe marker (-î) has thus played the role of a linker between the nominal form (*kuştin* ‘to kill’) and the theme argument (*gyandar-eke* ‘the animal’). An agent argument cannot be expressed in the same way. Hence, the nominal in (29) can only have a passive reading conveying the fact that the animal is killed, not that the animal has killed. This can be considered as evidence that the past stem is inherently passive whereas the present stem does not have this property.

Given that the past stem is inherently passive in nature, it is time to see how this is relevant to the clausal structure. As stated by Chomsky (2000, 2001), while active *v* is a strong phase head, passive *v* is not. Grounding their hypothesis on this assertion, Baker and Atlamaz (in progress) assume that the past stem is a conflation of a passive *v* and the V root, whereas the present stem is a conflation of active *v* and the V root. Along the same lines, the following view is adopted in this study with regard to the phasehood status of *v*.

(30)

v is a phase head if and only if it theta-marks a specifier in Spec- v P.²⁵

It is worth noting here that the difference between this view and that of Karimi (2010, 2013) is related to the ability of v to theta-mark its specifier. Karimi (2013), in revisiting the *defective intervention effect*, assumes that v in the past in Central Kurdish is a phase head but does not theta-mark its specifier. This is because v in the past lacks its own ϕ -features, which in turn disable it from assigning accusative case to the object. This view, however, is not adopted here.

To further support the claim in (30), there is a number of other ergative-like constructions in the Kurdish dialects which clearly demonstrate that the phasal status of v is dependent on whether it is able to theta-mark its specifier or not. For example, there is a number of nonagentive verbs (see also Holmberg and Odden 2004; Holmberg 2004; Karimi 2013) in some Kurdish dialects (e.g. Central Kurdish, Hawrami, and Badinani subdialect of Northern Kurdish) in which even in the present tense the same ‘ergative’ agreement-and-case pattern of past tense agentive verb is maintained. These nonagentive verbs include predicative possession ‘have’, necessity verbs such as ‘want’ and ‘need’, non-volitional states or events such as ‘be cold’ or ‘be hungry’, and potentiality expressions such as ‘to be able to’ or ‘to dare’. These verbs have either an experiencer or a possessor subject, hence they are referred to as nonagentive.

In the following, examples of the verb ‘want’ in the three dialects of Central Kurdish, Hawrami, and Badinani subdialect of Northern Kurdish are given in which the experiencer subject has oblique case, the direct object (the theme argument) has direct case, and the verb agrees with the object.²⁶ The agreement is shown in boldface letters.

²⁵ This view was actually adopted by an earlier version of Baker and Atlamaz (in progress). In the current version of their paper, the difference between past and present tense clauses is solely related to the phasehood status of v in that past stem does not constitute a phase whereas v in the present tense does constitute phase head. The PIC effect is thus the main factor involving the different agreement (and case) pattern. For certain reasons explained in later sections, their current view is not adopted here.

²⁶ Subjects (also other arguments) in Central Kurdish do not show (oblique) case. As stated above, the pronominal clitics seem to be the indirect manifestation of oblique case. The same is true for Hawrami (cf. Holmberg 2004).

(31)

a. *Central Kurdish*

ême **esp**=man na-w-**êt**.
We horse-3PL.CL NEG-want.PRS-3SG
'We do not want horses.'

b. *Badinani Northern Kurdish*

ama **hasp** na-vë-n.
1PL:OBL horse:PL NEG-be.necessary:PRS-3PL
'We do not want horses.'

(Haig 2008: 260)

c. *Hawrami*

æsp-e=š gæræk=**ene**.
horse-PL=3SG desire=COP.3PL
'He wants horses.'

(Holmberg and Odden 2004)

Since these verbs are clearly nonagentive, it is logical to assume that they do not assign a thematic role even in the present tense. The two arguments of these types of verbs are assigned inside VP, similar to the goal and the theme argument of a 'give' type verb. Thus, the present clauses of these nonagentive verbs have the same 'ergative' case and agreement pattern of past tense clauses in that there are two arguments in the clause with no *vP*-level phase boundary. This is clearly the reason they follow the same agreement-and-case pattern of past transitive agentive verbs.

Other types of verbs or constructions which do not theta-mark the subject in the Spec-*vP* even in the present tense include unaccusative verbs and passive constructions. Although Northern Kurdish does not have morphological passive, Central Kurdish and Hawrami do. Even in Northern Kurdish unaccusatives have only one NP involved in case and agreement. As shown in (32a) and (32b), both Central Kurdish and Hawrami have morphological passive, particularly a passive suffix on the verb. The agreement is shown in boldface letters.

(32)

- a. ewan **gul-yan** pe=de-d-rê-êt. *Central Kurdish*
They flower=3PL.CL to=IND-give.PRS-PASS.PRS-3SG
'They will be given flowers.'
- b. žiwa **gul-e=š** pænæ=mæ-ðt r-y-â. *Hawrami*
Zhiwa flower-PL=3SG.CL to=IND-give-PASS-3PL
'Zhiwa will be given flowers.'

(Holmberg and Odden 2004)

As can be seen in both examples, the verb agrees with the theme argument 'flower'. The goal argument has obviously become the subject of the passive sentence. Like nonagentive verbs, passive (particularly ditransitive passive) in Central Kurdish and Hawrami has an ergative agreement pattern (see also section 4.7.2). Although the tense of the clause in both examples is clearly present, the verb still agrees with the object whereas the subject is doubled by a pronominal clitic (an indirect manifestation of oblique case in both dialects).

Yet, as mentioned above, in Central Kurdish (also in Northern Kurdish), the ergative agreement pattern can also be found in possessive structures (have-constructions). This is also true for Hawrami (Holmberg and Odden 2004; Holmberg 2004). This is demonstrated for Central Kurdish in (33). Although the tense of the clause is clearly present, the verb agrees in person with the object and the subject is doubled by a pronominal clitic, which is enclitic on the object.

(33)

- a. min kitêb=im he-(y)e.
I book=1SG.CL exist-be.PRS.3SG
'I have books.'
- b. ême kitêb=man he-(y)e.
we book=1PL.CL exist-be.PRS.3SG
'We have books.'

Now that it is soundly clear that clauses with present stem and clauses with past stem are different, it is time to show how this difference manifests itself in the clausal structure, particularly the status of agreement morphemes and pronominal clitics.

4.6 The Syntax of Agreement in Central Kurdish

As argued in the previous section, since v in the past tense is not a phase head (on the grounds of being passive in nature), its complement is thus not spelled out. On the contrary, since v in the present tense is a phase head (on the grounds of being active and theta-marking a subject), its complement is then a spelled out domain, invisible to elements higher in the structure. What this means is that there is a phase boundary internal to the clause in active present clauses but not existent in past clauses in both Northern Kurdish and Central Kurdish. Following the assumption in (30), it is thus the ability to theta-mark the subject argument in Spec- v P that is responsible for the crossed agreement pattern in the language. In the past tense, the subject is not theta-marked in Spec- v P but rather in Spec-AuxP, whose head contains agreement features. This results in the agreement head Aux probing down and agreeing with the object if there is one, otherwise with the subject via cyclic Agree (Rezac 2003; Béjar and Rezac 2009) (see below). In the present tense, the subject is theta-marked in Spec- v P. This makes the agreement head to always agree with the subject, which is the highest argument within the verbal argument structure. This is basically the account that will be argued for in this section.

In order to account for the difference in the phasal structure of clauses and the different agreement-and-case pattern in past and present in Adyaman Kurmanji (a variety of Northern Kurdish), Baker and Atlamaz (in progress) develop a theory in which there is an agreement-bearing head F lower than T and higher than v . They associate the agreement F with Voice which is above v P. As a result, finite verbs agree with the object rather than the subject in past tense clauses in Northern Kurdish. This is because the subject, being first-merged as Spec of VoiceP, does not intervene between the agreement head Voice and the object, blocking an Agree relation between the two. According to them, the difference in the phase structure is mainly related to the effect of PIC. In the past tense, as shown in the schematic structure in (34a) below, the agreement head undergoes cyclic Agree (Rezac 2003; Béjar and Rezac 2009), agreeing downward with the object if there is one, otherwise it agrees upward with the subject. That is, if v is past, the agreement-bearing head Voice is able to see the direct object inside VP since v P is not a phase in the past. In the present tense, as shown in the schematic structure in (34b), however, the agreement head is not able to see the direct object inside VP because such an operation is prevented by PIC. In other words, since v P in the present is a phase, it will

prevent object agreement. Thus, in the present tense, Voice always agrees upward with the subject. In both tenses, Voice assigns direct case to the DP it agrees with, and oblique is assigned to all other arguments. It is important to note that their agreement-based account straightforwardly predicts that a language can have almost the same verb agreement pattern of Northern Kurdish without having a case distinction between direct and oblique cases. This is because agreement does not depend in any way on structural case on their view.

(34)

a.

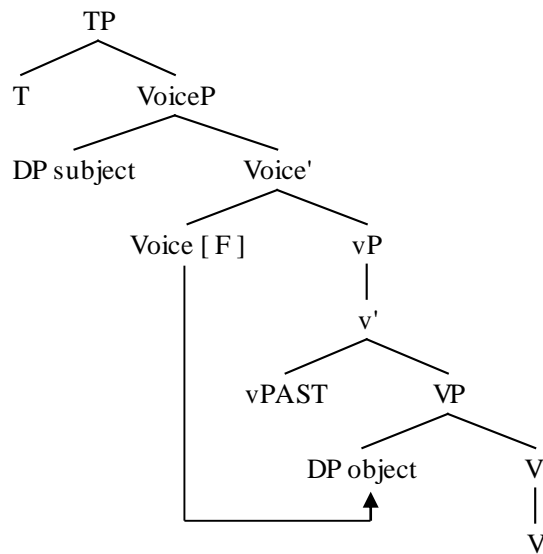

b.

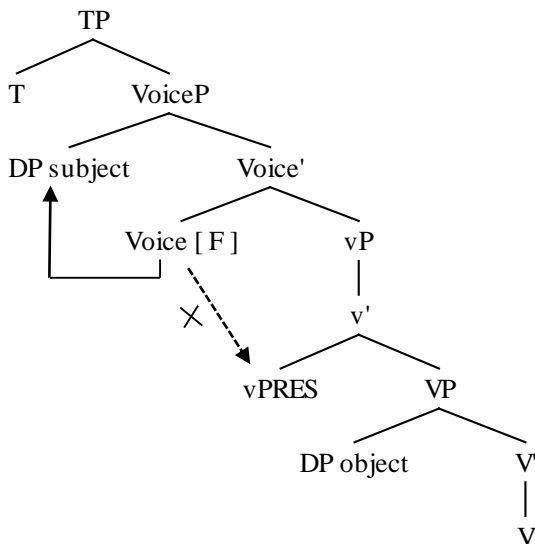

Although the passive nature of the past stem shows in the clause structure, or in participles and nominalizations, simple clauses with a past stem verb are obviously not passive. Like in Northern Kurdish, the ergative subject (the subject of the past clause) in Central Kurdish c-commands and can bind the direct object, just as the nominative subject c-commands the direct object in a present clause as shown by phenomena such as reflexive binding and quantifier scope, shown in (35).

(35)

- a. Azad dwênê xo=î otombêl-eke=î lê-xurrî-Ø.
 Azad yesterday self=3SG.CL car-DEF=3SG.CL PREV-
 drive.PST-3SG
 ‘Yesterday, Azad himself drove the car.’
- b. Azad emro xo=î otombêl-eke lê-de-xurr-êt.
 Azad today self=3SG.CL car-DEF PREV-IND-drive.PRS-3SG
 ‘Today Azad himself drives/is driving the car.’

Thus, although the *vP* in the past is passive, the clause as whole is clearly not. Baker and Atlamaz (in progress: 15) provide arguments from other Indo-European languages such as English for this phenomenon. For example, although participles in English are intrinsically passive in isolation, as shown in (36a), they are used in active clauses when they are preceded by the transitive auxiliary *have*, as in (36b).

(36)

- a. A well-*directed* film.
 b. John has *directed* the film.

They claim that *vP* in the past in Northern Kurdish is the same, except that the transitive auxiliary equivalent to *have* in English (36b) is phonologically null. Following their view, I also assume the existence of a transitive auxiliary in Central Kurdish. However, different from their view, I assume it is present in both present and past tense clauses in Central Kurdish. The difference is that the transitive auxiliary in the past tense theta-marks the subject and has to do so because *v* is inherently ‘passive’, lacking capacity to assign a subject role or assign object case, whereas in the present tense clause it does not theta-mark the subject. Instead, the subject in the present tense is theta-marked in its normal position, namely, in the specifier of *vP*.

It remains to be seen whether this transitive auxiliary is related to the auxiliary ‘be’ used with a number of past verb forms or not. As seen in section 2.6.2, with a number of verb forms in the past tense, auxiliary ‘be’ is used. For example, past perfect aspect is formed via the use of auxiliary ‘be’ plus the past stem of the verb, as shown in (37). None of the verb forms in the present tense has such a ‘be’ auxiliary (see section 2.6 for paradigms of verbs in the present and past tense).

(37)

ke	hat-im,	roîşt-bû-n.
that	come.PST-1SG	go.PST-be.PST-3PL

‘When I came, they had gone.’

Since it is not used in all verb forms in the past, this overt auxiliary is obviously different from the phonologically null auxiliary that assigns the subject theta role in the past tense. Whereas the theta-assigning auxiliary is ever present in the structure in both past and present clauses, this auxiliary ‘be’ is only present to convey certain tense and aspect interpretation of the clause. As generally known, auxiliary verbs, especially auxiliary ‘be’, are different from main verbs in that they reflect the ‘failures’ of the inflectional system, so to speak. In this respect, the extensive use of auxiliary ‘be’ in the past tense in Central Kurdish is perhaps due to the defective and participial nature of the past stem verb. The overt auxiliary is thus present to support inflectional material that cannot be added directly to the main verb. In other words, it bears the tense and agreement morphology which cannot be expressed on the non-finite verb stem.

In order to determine the position of the agreement head in Northern Kurdish, Baker and Atlamaz (in progress) provide some morphological evidence, which comes from the complex tense constructions. In particular, they refer to the tense-aspect combinations present progressive and present perfect in which the present tense copula is an ingredient in their constructions. However, this is not exactly the case in Central Kurdish anymore (or even in some varieties of Northern Kurdish). There is no need for the use of copula in the present (or even past) progressive, as it is conveyed via the use of the indicative marker *de-*. I take this to be an instance of grammaticalisation in the language; that is, it might have been the case that the present auxiliary ‘be’ is actually used with the verb stem to convey progressive aspect, as is the case in Adyaman Kurmanji now.

According to Baker and Atlamaz (in progress: 9-10), the agreement suffix is directly attached to the verb root, and other tense-aspect morphemes come outside of it. They state that the present perfect tense has the morpheme order Verb-AGR-Tense, as shown in (38) below.

- (38) *Adyaman Kurmanji*
 rvi-m-e.
 run.PST-1SG-COP.PRS
 ‘I have run.’

Baker and Atlamaz (in progress: 10)

They submit that the morpheme *-e* is the third person tense form of copula, which has become the realization of the present tense in this combination. However, this is not exactly the case. As in Northern Kurdish, the present tense auxiliary ‘be’ is used in Central Kurdish with the past stem of the main verb, as shown in (39). Although the copula or auxiliary ‘be’ is the realization of tense, the agreement morpheme is not directly suffixed to the verb root. It is obvious, for instance, that the perfect aspect suffix is attached to the verb root, not the agreement suffix (see also section 3.4 for the morpheme order in Central Kurdish).

- (39)
 sêw-eke=m xward-û-e.
 apple-DEF=1SG.CL eat.PST-PERF-be.PRS.3SG
 ‘I have eaten the apple.’

As can be seen in the English translation of the sentence, the present auxiliary ‘be’ in Central Kurdish is equivalent to the present tense auxiliary ‘have’ in English. Present perfect is formed by having a past stem under a present tense (represented here as auxiliary ‘be’). In other words, the tense of the sentence in (39) is clearly present because the present tense auxiliary ‘be’ is used, and the past stem of the main verb ‘eat’ does not affect the tense of the whole clause. However, since the past stem of the main verb is used, the agreement pattern should naturally follow the ergative pattern, that is, the verb should agree with the object. It is striking to notice that the agreement morpheme, represented in the conjugated form of auxiliary ‘be’, is not different from the agreement

morpheme seen in (38). Consider what happens when the object is changed into a pronominal, as shown in (40). Since the object in (40a) is singular, the object-agreement marker is phonologically null prompting only the realization of *-e* (also third person of conjugated copula ‘be’). However, when the object is plural, as in (40b), the present copula seems to be null whereas the agreement marker seems to be realized.

(40)

- a. xward-û=m-e.
eat.PRS-PERF=1SG.CL-be.PRS.3SG
‘I have eaten it.’
- b. xward-û=m-in.
eat.PRS-PERF=1SG.CL-be.PRS.3PL
‘I have eaten them.’

As a result, I conclude that the auxiliary ‘be’ seen in (39) and (40) is the conjugated form with the agreement morpheme. This also means that the agreement is added to the overt auxiliary, not the main verb. Furthermore, the overt conjugated auxiliary form should not be seen as the present tense marker, as Baker and Atlamaz (in progress) do.

With regard to the position of the agreement head, it is the case that the agreement morpheme comes last within the morpheme order and follows the overt auxiliary if present, as seen in the above examples. In other words, it is not as low as Baker and Atlamaz (in progress) claim for Northern Kurdish. This means that tense-bearing auxiliary ‘be’ is lower than the agreement head, and that the agreement morpheme in Central Kurdish is the final suffixal morpheme within the verbal complex, hence highest within the verbal suffixal morphology (see section 3.4 for a discussion on the derivation of verbal structure).

Hence, instead of proposing an agreement head Voice as Baker and Atlamaz (in progress) do (see the structures in (34) above), I propose that agreement resides in the head of the AuxP, the transitive auxiliary which is phonologically null. This projection is the highest among the suffixal projections seen in the previous chapter. Based on the arguments presented that v_{PAST} in Central Kurdish and other Kurdish dialects is inherently passive, it follows that v in the past does not theta-mark a specifier in Spec- vP . This means that the subject does not originate in the Spec- vP in the past. Instead, it is theta-marked in the

Spec-AuxP, as demonstrated in (41a) below. This is indeed what causes the crossed-agreement (split-ergative) in the language. In the present tense, the subject is in the Spec-vP since *v* can theta-mark its specifier, as shown in (41b).

(41)

a. Past

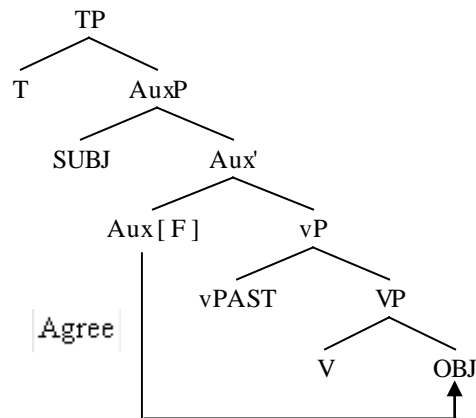

b. Present

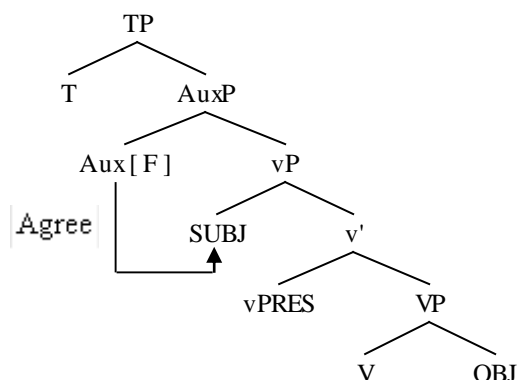

The agreement-bearing head *Aux* probes downward to find a visible DP to agree with. In the past tense clauses, *Aux* finds the object inside *VP* to agree with. This adequately explains why object-verb agreement but not subject-verb agreement occurs in the past transitive. As shown in (41a), through *Probe*, *Aux* finds the closest (in terms of c-command) matching interpretable ϕ -features, and through *Agree* it values and erases its uninterpretable ϕ -features. Hence, the $u\phi$ -features of *Aux* are valued by the object, being the closest c-commanded DP, and in return the direct case (if there is any morphological case) is assigned to the object. This *Agree* relation is possible because *Aux* c-commands the object and there is no other DP intervening between the two. And, most importantly, the agreement is not blocked by PIC since *v* in the past is not a phase head.

As stated above, Central Kurdish has no morphological case on its DPs. In this respect, the object DP does not get a direct case in the past tense. There is only agreement with the verb, and this object-agreement is only visible (full agreement in number and person) when the object DP is pronominalized. Otherwise, object-verb agreement in the past is realized as default 3rd person singular. Both full object-verb agreement (42b) and default object agreement (42a) are shown below, repeated from (10).

(42)

- a. min name-eke-an=im nard-Ø.
 I letter-DEF-PL=1SG.CL send.PST-3SG
 ‘I sent the letters.’
- b. nard-in=im.
 send.PST-3PL=3SG.CL
 ‘I sent them.’

In contrast, in the present tense clauses, as shown in the schematic structure in (41b), the set of unvalued ϕ -features of Aux will establish an Agree relation with the ϕ -set of the subject. That is, Aux finds the closest visible DP, which is the subject, to agree with. This is because the subject is assigned a theta role in the Spec- ν P, which makes it the closest c-commanded DP. Hence, Aux assigns direct case (if there is any morphological case) to the subject and in return the subject values the [$u\phi$] of Aux. Unlike in the past tense clause, Aux cannot enter into the Agree relation with the object for two obvious reasons. First, the subject, generated in the Spec- ν P, is the closest c-commanded DP, which intervenes between Aux and the object. This obviously prevents Aux with its unvalued ϕ -features from agreeing with the object. Second, since ν in the present is active, it is a phase. Thus, agreement with the object inside VP complement is blocked by PIC.

Although there is no morphological case (direct case) on subject DPs in Central Kurdish, the subject-verb agreement in the present tense is quite evident. As explained in section 4.3.1, the verb agrees in person and number with the subject via a relevant verbal agreement marker, as shown in (43) below, repeated from (7). The agreement is shown in boldface letters.

(43)

- a. **minal-*eke-an*** **de-rro-*n*** **bo** **xwêndinge.**
child-DEF-PL IND-go.PRS-3PL to school
‘The children are going to school.’
- b. **ew** **hêwaş** **nan** **de-xw-*at*.**
He slowly bread IND-eat.PRS-3SG
‘He eats food slowly.’

What remains is the explanation for the subject-verb agreement in the past intransitive clauses. As mentioned above, following Rezac (2003) and Béjar and Rezac (2009), I propose that when a functional head probes downward and finds no goal, it will probe upward instead (Cyclic Agree). This Cyclic Agree happens in the case of past intransitive clauses in Northern Kurdish and Central Kurdish. Since there is no DP inside vP , the agreement bearing head Aux, when probing downward to find a visible DP to agree with, cannot find any DP inside vP , it will instead probe upward and will thus find the subject DP in Spec-AuxP. This in turn explains the subject-verb agreement in past intransitive clauses, as in the example of (12), repeated here as (44).

(44)

- ke **ême** roîşt-**în**, **êwe** geîşt-**in**.
When we leave.PST-3PL you arrive.PST-2PL
‘When we left, you arrived.’

Hence, these operations are responsible for the object agreement in the past transitive clauses and the subject agreement in the present transitive and intransitive in Central Kurdish and other dialects.

Karimi (2013) assumes that the agreeing head in Central Kurdish is the highest head, namely T. This is not adopted here because of the assumption that T does not contain any tense feature but only a mood feature. And, these are realized as prefixes, as argued in the previous chapter. Karimi’s account is case-driven in that he assumes that T does not agree with the subject in past tenses in Northern Kurdish and Central Kurdish because the subject has inherent case (‘dative’) assigned to it by v_{PAST} . However, I find this analysis unnecessary and somewhat problematic. This is because the same verbal agreement markers that function as subject agreement markers in the present tense can also function

as subject agreement markers in the past intransitive. Besides, the subject in the past does not have a distinctive ergative or dative case; rather, it has oblique case similar to that of objects of present transitive verbs. This is clearly the case in Northern Kurdish since it has morphological realization of case on its DPs. Aside from its case-driven problems, agreement features cannot be in the T head because this would always result in agreement with the subject. For these reasons, the agreement-driven case approach adopted here works best, not only for Central Kurdish but also for other Kurdish dialects whether they have morphological case or not. In other words, the agreement pattern determines the case pattern, not the other way around, as Baker (2013) and Baker and Atlamaz (in progress) argue for.

4.7 The Status of the Pronominal Clitics

A distinctive feature of past tense subjects in Central Kurdish (and Hawrami) is that they are doubled by a pronominal clitic, which, as explained in section 4.3.3, is encliticized to the first non-subject and non-adjunct constituent inside VP. Karimi (2010) submits that this pronominal clitic is an indirect manifestation of ergative (dative) case. Karimi (2013) presents a different view, however, according to which the subject pronominal (oblique) clitic is a manifestation of an agreeing applicative head, which is used to assign the subject theta-role in past tense clauses. In this respect, finite verbs freely agree with the object in past tense clauses in Northern Kurdish but not in some versions of Central Kurdish due to the presence of this clitic. According to him, the pronominal clitic is a head which is fully specified for phi-features and intervenes between T (the agreement head in his view) and the object, preventing T from agreeing with the object in Central Kurdish. A stark problem for this view is Hawrami, which has subject clitics like Central Kurdish does, but the verb can still agree with the object in the past (see Holmberg and Odden 2004). Besides, in Central Kurdish, the same pronominal clitic can be used with other DPs such as possessors and objects of prepositions. Most importantly, the same pronominal clitics, which are used with past transitive subjects, are also used in the present tense to represent the object when it is *pro*.

Hence, since there is no morphological case on DPs in Central Kurdish, I take these pronominal clitics to be the indirect manifestation of oblique case. Most of the functions of pronominal clitics such as possessor in nominal structures, object referencing in the present tense, and subject agreement in the past transitive clause, are functions historically

associated with oblique case in Middle Iranian languages (see Haig 2008, Korn 2009: 159).

In the past tense, the object gets direct case because it agrees with the agreement head Aux. This leaves the subject to have oblique case, following the assumption that any other argument which does not agree with the agreement head gets oblique. Since there is no morphological realization of case in Central Kurdish, the subject is doubled by an oblique pronominal clitic. Interestingly, the subject of past intransitive is not doubled by any pronominal clitic simply because the subject agrees with the agreement head. This also explains why the pronominal clitic should not be taken to be a subject-agreement morpheme. In contrast, in the present tense, the subject gets direct case because it agrees with the verb. Any other argument including the object, which does not agree with the verb, gets oblique case. This properly captures the fact that the same pronominal clitic represents object in the present tense.

Although there can be differing views to the idea that clitics are indirect manifestation of oblique case, they are not adopted in this study. For example, Baker and Atlamaz (in progress) tentatively assume that these clitics can be seen as weak pronouns not marked for case. Although these clitics were present in Middle Iranian languages, as mentioned above, and were lost in Northern Kurdish, they are still found in Tatic languages which have also maintained an oblique/direct case system. Hence, according to them, these clitics have nothing important to do with how case and agreement work on finite verbs in Iranian languages. Having the same distribution as oblique DPs in Northern Kurdish does not mean that that the clitics are oblique in nature. Instead, it might be related to the fact that clitics are not used in positions where the agreement head agrees with DP. Thus, the use of clitics might be seen as a more economical form of pronominalization, which makes pro-drop in the language possible. This differing view still does not affect the analysis proposed in this chapter works. In other words, even if seen as a more economical form of pronominalization, clitics do not have anything to do with how the verbal agreement markers behave.

Another distinct view concerning clitics is that of Jügel (2009). In line with Bynon (1979) and Haig (2008), Jügel (2009: 151) believes that the subject of past tense in Central Kurdish was originally a topic, in a hanging-topic position, which was marked or doubled by a pronominal clitic in the clause. This relation between the subject of past tense and

the clitic can be seen as ‘topic agreement’, which was later reinterpreted as verbal agreement. This was followed by the abandonment (but not cancelling) of the object-verb agreement. According to him, the option of expressing the object via a verbal agreement suffix is retained only when the object is not a full form. He believes that the pronominal clitics function as subject agreement in the past transitive tense whereas the verbal agreement affixes function as pronouns or may refer to the object or any other oblique form. Hence, he assumes that this state of affairs only reflects an earlier split ergativity system in Central Kurdish without the language being a split ergative now. A problem with this view is that clitics are not only used in the past tense but also in the present. In other words, the fact that clitics can be used in the present tense to cross-reference the object makes the claim that they are subject verbal agreements weak.

Thus, whether they are the indirect manifestation of oblique case in Central Kurdish or they have nothing to do with how agreement (and case) works in the language, clitics do not pose a problem of how agreement works in the language. In particular, the analysis offered in this section still stands. The issue of the exact syntactic characteristics of clitics can be left for further research.

4.8 Other Ergative-like Constructions

In the following, a number of other ‘ergative’ constructions are discussed which attest the reliability of the analysis proposed in the previous section. In each of these structures, since the *v*, like *v*_{PAST}, cannot theta-mark its subject in its specifier, an ergative agreement pattern is found. The interesting aspect of such structures is that even though some of them are in the present tense, they still exhibit split ergative agreement pattern. This is obviously due to the fact that the verb stem cannot theta-mark the subject in its specifier. It is also worth noting that there are various non-ergative languages (e.g. Old English, Dutch, Bengali, Spanish) that also show non-nominative syntax with very much the same types of predicates (see Mendívil Giró (2012) for an analysis of such predicates in Spanish).

4.8.1 *Applicative Constructions*

It can be assumed that Central Kurdish and Hawrami could have the same oblique-direct case distinction (but not spelled out overtly at PF) as Northern Kurdish. This is in fact

Karimi's (2010, 2013) view, at least for subjects in past versus present clauses. An argument for such an assumption can be provided by a kind of applicative alternation, which can be found in both Central Kurdish and Hawrami, as demonstrated in (45) and (46) respectively. It is worth noting that such a structure is not found in Northern Kurdish. Thus, it can be argued that this construction shows the oblique-direct case distinction in that whatever argument the agreement head agrees with gets covert direct case whereas any other argument gets oblique (represented by a clitic).

(45) *Central Kurdish*

- a. pare=m da-Ø pê=t. (separate P)²⁷
 money=1SG.CL give.PST-3SG to=2SG.CL
 'I gave you money.'
- b. pare=m pê=da-î(t). (incorporated P)
 money=1SG.CL to=give.PST-2SG
 'I gave you money.'

(46) *Hawrami*

- a. puł=im da pænæ=l. (separate P)
 money=1SG.CL gave-3SG to=2SG.CL
 'I gave you money.'
- b. puł=im pænæ=da-i. (incorporated P)
 money=1SG.CL to=gave-2SG
 'I gave you money.'

(Holmberg and Odden 2004)

In both (45a) and (46a), the goal argument is low in the VP, clearly after the verb. This is also the case for goal arguments in Northern Kurdish. The difference however is that goal arguments in both Central Kurdish and Hawrami are expressed as PP. A structure for the example in (45a) shows that the DP theme argument 'money' is higher than the goal

²⁷ It is also possible to express the same sentence with another preposition, which still means 'to', as shown below. In this case, the complement of the preposition is an independent pronoun rather than a clitic.

pare=m da-Ø be to.
 money=1SG.CL give.PST-3SG to you
 'I gave you money.'

argument. This is why the agreement head Aux agrees with the theme argument rather than the goal argument, as can be seen in (47) below.

(47)

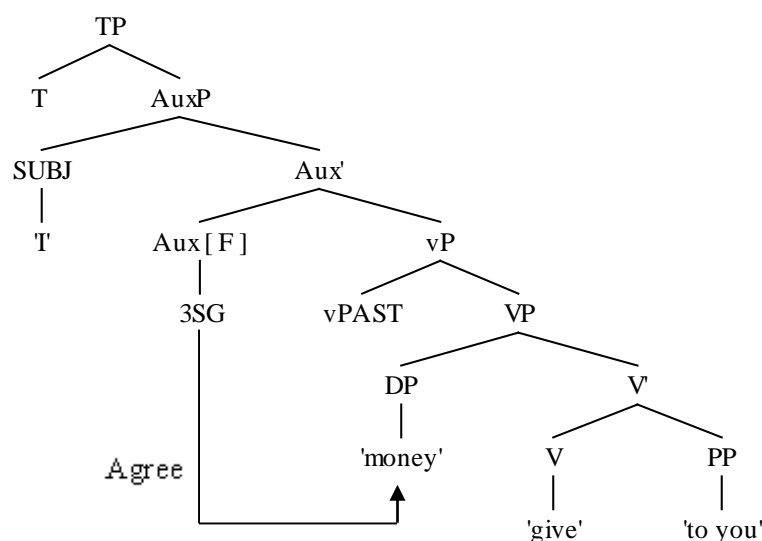

Both (45b) and (46b) are alternative constructions in which the separate P shifts to the right of the verb, which might be seen as an instance of head movement (Baker 1988). In both (45b) and (46b), the verb agrees with the goal argument, which is pro-dropped, not the theme argument as it is the case in (45a) and (46a) and the Northern Kurdish equivalent.²⁸ I infer that the reason for this is that the goal argument in (b) examples has moved to the edge of the VP which makes it higher than the theme argument, as shown in the schematic structure in (48) below. Thus, the agreement is with the pro-dropped goal argument. And, if it had morphological case, it would have direct case rather than inherent oblique case. This in fact seems to be the case because the subject, which does not agree with the verb, is doubled by a pronominal clitic, an indirect manifestation of oblique case in Central Kurdish. This alternative structure, seen in (45b) and (46b), clearly manifests the object agreement in both languages. The agreement head Aux agrees with the closest DP object in terms of c-command. Since the goal argument becomes closer than the theme argument, the agreement head Aux agrees with it.

²⁸ In most Iranian languages (e.g. Central Kurdish and Hawrami) goal arguments in active applicative constructions are only realized as *pro*. It is not clear why this is the case, and it is not the scope of this thesis to discuss this issue.

(48)

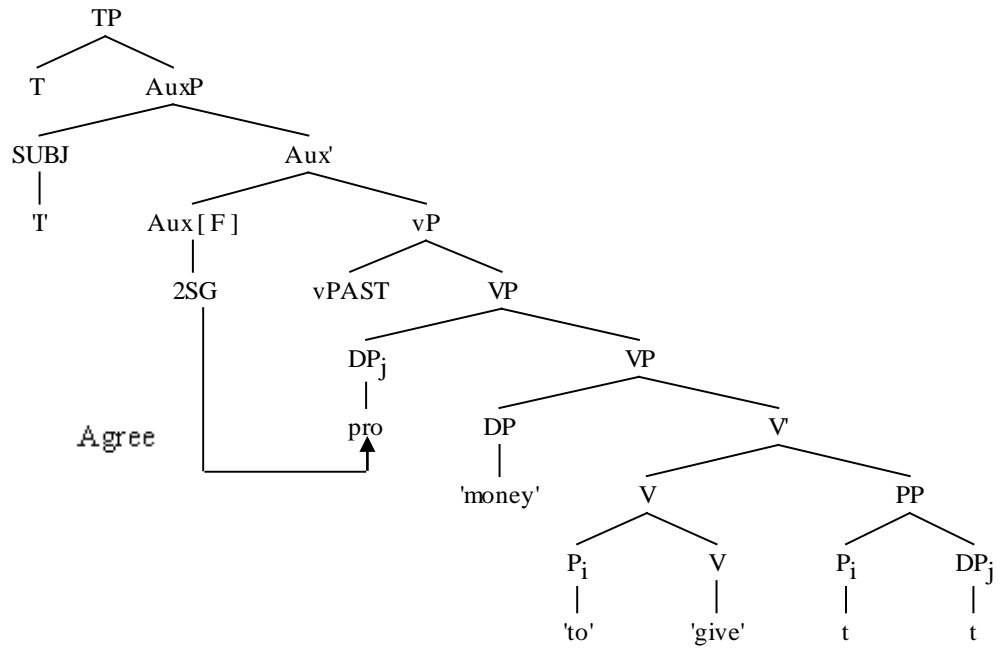

4.8.2 The Passive Ditransitive

The crossed agreement pattern can also be attested in the passive construction. Central Kurdish, as well as Hawrami, has a standard morphological passive construction. As explained in section 2.5.3, passive is formed by adding a passive suffix (*-rê* for present and *-ra* for past) to the present verb stem. It should thus be the case that the verb should agree with the subject of the passive clause, and this is in fact the case, as can be seen in (49).

(49)

- a. *sêw-eke-an xu-ra-n.*
apple-DEF-PL eat.PRS-PASS.PST-3PL
'The apples were eaten.'
- b. *sêw-eke de-xu-rê-(ê)t.*
apple-DEF IND-eat.PRS-PASS.PRS-3SG
'The apple will be eaten.'

As shown in the schematic structure in (50) below, since the sentence is passive, the object has raised to become the subject of the sentence. Thus, when the object DP moves to become the subject of the sentence, it moves to the Spec-TP (see section 3.6 for a

discussion on argument positions). When the agreement head probes downward and finds no DP to agree with, it probes upward via cyclic agree to find the subject DP in the Spec-TP.

(50)

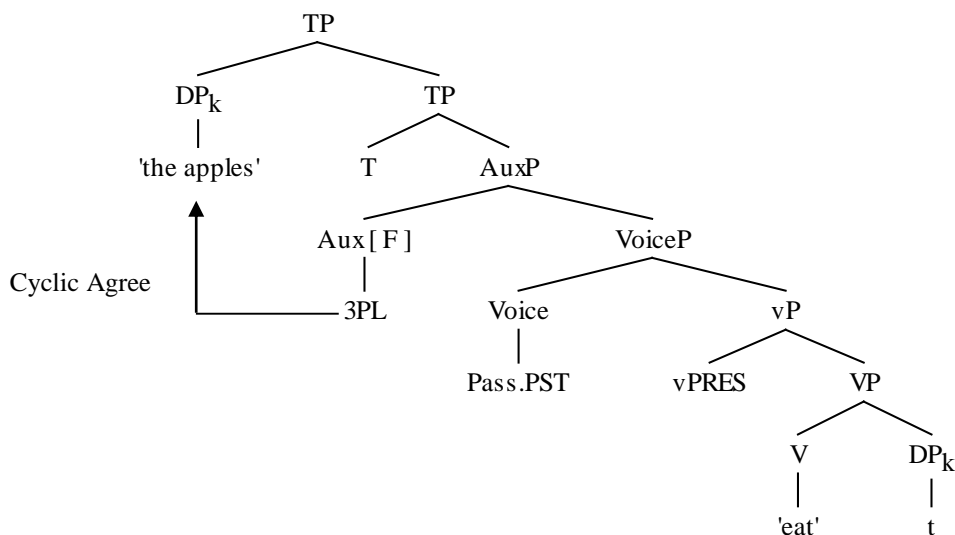

A remarkable characteristic with regard to passive formation, first discussed by Holmberg and Odden (2004), is in fact the ditransitive construction in which either of the theme (the direct object) or the goal argument (the indirect object) can become the subject of the passive clause, much like the applicative construction seen in section 4.8.1. This is exemplified in (51) below. The agreement is shown in boldface letters.

(51)

- a. **Azad** dyarî-eke de-d-at be Mary.
Azad gift-DEF IND-give.PRS-3SG to Mary
'Azad will give the gift to Mary.'
- b. **dyarî-eke** de-d-rê-(ê)t be Mary.
gift-DEF IND-give.PRS-PASS.PRS-3SG to Mary
'The gift will be given to Mary.'
- c. Mary **dyarî-eke=î** pê=de-d-rê-(ê)t.
Mary gift-DEF=3SG.CL to=IND-give.PRS-PASS.PRS-3SG
'Mary will be given the gift.'

As can be seen in (51b) above, when the direct object (the theme argument) becomes the subject, there is no crossed-agreement pattern (ergative pattern), and the agreement head Aux agrees with the subject (the theme argument) similar to the passive monotransitive seen in (49) above. The reason for this is that the agreement head Aux, in probing downward to find a DP, finds the goal argument which is a PP, and this does not count as a goal for agreement. Thus, through cyclic Agree, it probes upward to find the derived DP subject in the Spec-TP. This is shown in the schematic structure in (52) below.

(52)

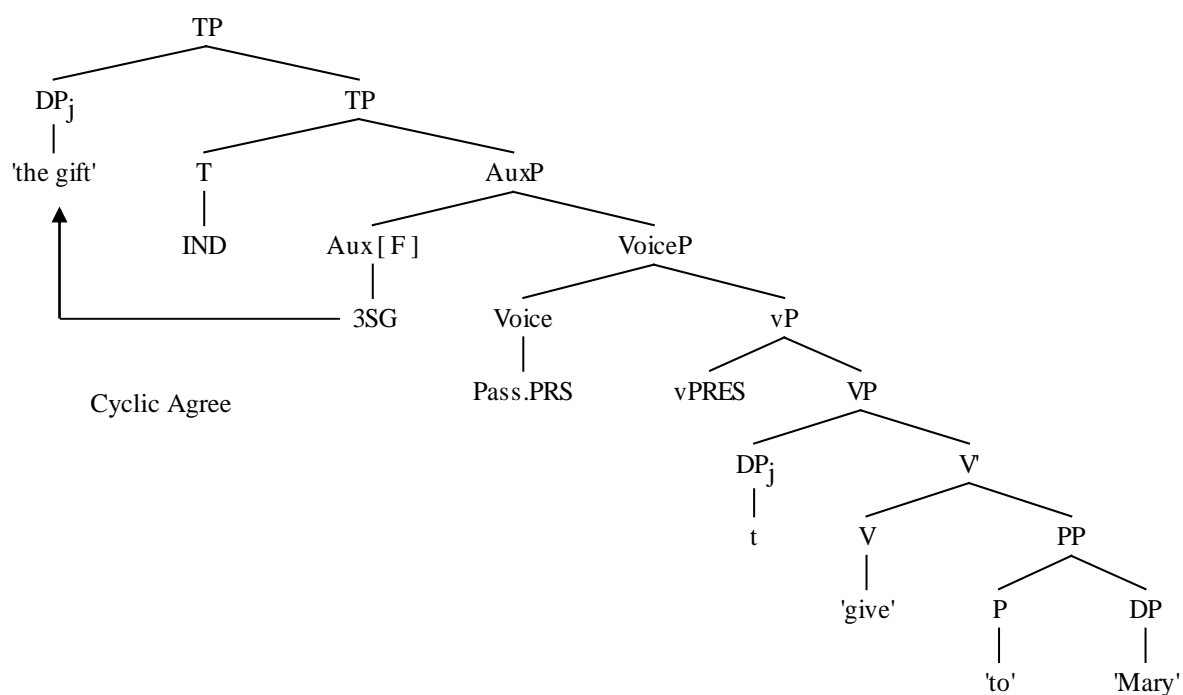

However, when the indirect object (the goal argument) becomes the subject of the passive sentence, the finite verb agrees with the theme argument (object agreement/ergative pattern), as demonstrated in (51c) above. That is, the ergative pattern will surface which results in the Aux agreeing with the object, as is normally the case in active past transitive clauses. An explanation for this ergative agreement is that the DP indirect object inside the PP moves to the Spec-TP to become the subject of the passive sentence. When the agreement head probes downward to find a DP to agree with, finds the DP theme argument inside the VP.²⁹ The v_{PRES} does not count as a phase head since it does not theta-

²⁹ In fact, a common tendency by native speakers is to think that that the agreement is between the verb and the subject, not the object. Thus, most speakers would tend to keep the same agreement markers even when the object is pluralized, shown in (a) below. Support for this uncertainty among speakers can easily be found when the subject is pluralized, as in (b) below. The subject is doubled by a clitic =*man* but the

mark in its specifier, as stated in (30). Concerning the preposition, it head-moves to attach to the verb. The schematic structure for the example in (51c) is shown in (53) below.

(53)

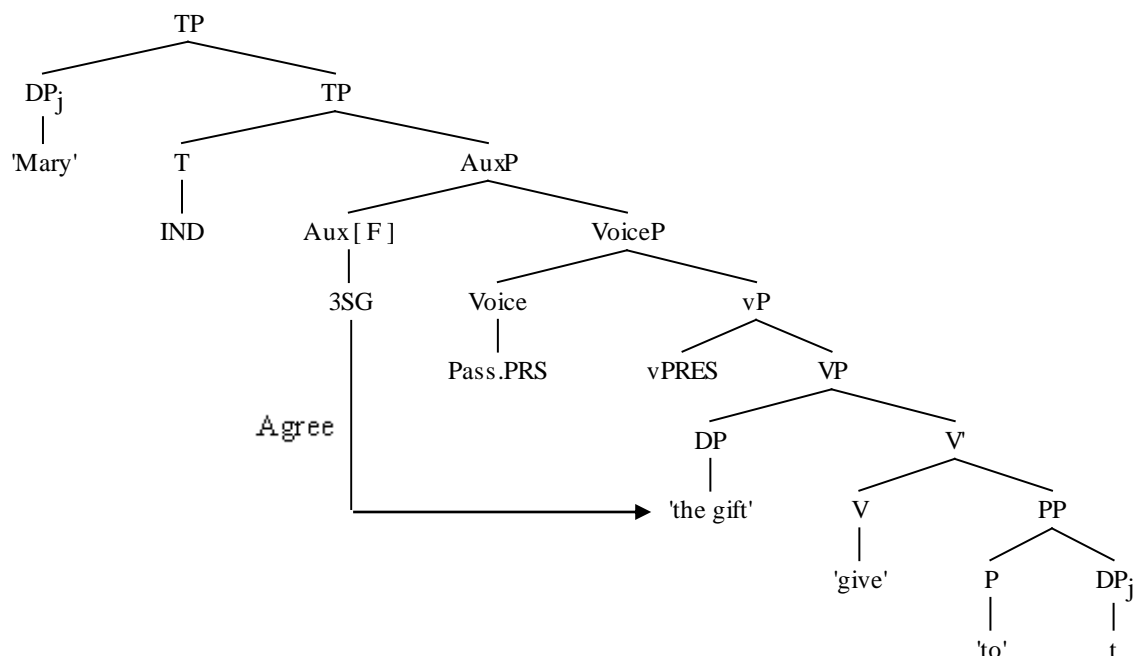

This is also the case in Hawrami, as shown in (54) below which is an example of the passive ditransitive. In this example, the goal argument has become the subject of the clause. Just as in (51c) example of Central Kurdish, the finite verb agrees with the theme argument (the direct object), not the goal argument. The subject is doubled by a pronominal clitic. The agreement is shown in boldface letters.

(54) *Hawrami*

Žiwa **gul-e=š** pænæ=mæ-ður-y-â.
 Zhiwa flower-PL=3SG.CL to=IND-give-PASS-3PL
 ‘Zhiwa will be given flowers.’

(Holmberg and Odden 2004)

agreement marker remains the same, namely 3rd person singular. This is because the object ‘the gift’ is singular.

- (a) *min **dyarî-êke-an=m** pê=de-d-rê-(ê)t.
 I gift-DEF-PL=1SG.CL to=IND-give.PRS-PASS.PRS-3SG
 ‘I will be given the gift.’
- (b) ême **dyarî-êke=man** pê=de-d-rê-(ê)t.
 we gift-DEF=1PL to=IND-give.PRS-PASS.PRS-3SG
 ‘We will be given the gift.’

Holmberg (2004) assumes that the ergative pattern that can be seen in (54) is related to the direct object (the theme argument) not getting Case from *v*. In fact, he maintains that ‘any structure with two nominal arguments where case is not assigned in the ‘normal way’ to the object will exhibit the ergative case-and-agreement pattern.’ Clearly then, this account predicts that agreement is driven by case. However, any case-driven account of agreement is not favored here. This is because, for example, it does not explain why the goal argument in (45b) and (46b) of the applicative construction can agree with the finite verb whereas the goal argument in (51c) and (54) cannot. The agreement-driven approach, which is adopted here, explains this difference. Hence, the striking difference between the applicative structure where the goal argument can agree with the finite verb and the passive ditransitive where the goal argument cannot agree with the verb is clearly related to the structural position of the goal with regard to the agreement head (see the difference in the structures (48) and (53)).

Thus, although different verb stems (past vs present) are used, the clausal structure of an applicative construction and a passive ditransitive construction is not very dissimilar. This is because in both cases the subject is not theta-marked in the Spec-*v*P. In other words, following the assumption in (30), even in the present tense, if the subject is not theta-marked in the Spec-*v*P, an ergative agreement pattern can be found, as can be seen in the Central Kurdish example of (51c) and the Hawrami example in (54).

4.8.3 The Possessive Construction

As briefly referred to in section 4.5, the possessive construction in Central Kurdish is formed via the use of the verb (*hebûn*) ‘to have’ or ‘to exist’. Karimi (2013) believes that Kurdish (both Northern Kurdish and Central Kurdish) *hebûn* as a lexical verb cannot be considered an equivalent to English *have*. This is ‘an intransitive existential verb’ (Karimi 2013: 70). Thus, having no equivalent lexical verb to English *have* is typical of ergative languages, he believes. This is indeed right insofar as *hebûn* is formed on two verbs, which are *he* meaning ‘to exist’ and *bûn* meaning ‘to be’.

This construction has an ergative alignment even in the present tense. As demonstrated in (33) and repeated here as (55) for convenience, the subject is doubled by a pronominal clitic, a characteristic of past transitive subjects and an indirect realization of oblique case.

The object agrees with the verb in number (default agreement), again a characteristic of past transitive (ergative) constructions.

(55)

- a. min kitêb=im he-(y)e.
 I book=1SG.CL exist-be.PRS.3SG
 ‘I have books.’
- b. ême kitêb=man he-(y)e.
 we book=1PL.CL exist-be.PRS.3SG
 ‘We have books.’

The possessive construction is also the same in Hawrami and Northern Kurdish, exemplified in (56) and (57) respectively. That is, the agreement pattern follows that of the past transitive structures, namely the ergative pattern.

(56) *Hawrami*

- a. ktew=m hæñ
 book=1SG.CL have.PRS-3SG
 ‘I have a book.’
- b. ktew-e=mân hæñ-e
 book-PL=3PL.CL have.PRS-3PL
 ‘We have books.’

(Holmberg 2004)

(57) *Northern Kurdish*

- a. pirsyar-eke min he-ye.
 question-INDEF me.dat be.there-3SG
 ‘I have a question.’
- b. penj zarok-en wi ha-ne.
 five child-PL him.DAT be.there-3PL
 ‘He has five children.’

(Karimi 2013: 70)

Although Holmberg (2004) offers a primarily case-driven account for Hawrami, the same analysis, i.e. agreement-driven account, offered for past clauses can also explain possessive construction. Karimi (2013), following Cuervo (2003), believes that in languages where the possessive constructions make use of an intransitive ‘to be’ verb (as he believes is the case in Kurdish), both arguments the subject (possessor) and the object (possessed) ‘are licenced by a low applicative head which is in turn a complement to the intransitive *to be* verb’ (Karimi 2013: 71). This explanation again seems to be case-driven and also superfluous. There is no need for a different structure depending on the use of the verb. However, as Holmberg (2004) argues for Hawrami possessive constructions, the possessive construction in Central Kurdish is literally equivalent to ‘To me is a book’, and the use of ‘be’ verb in the construction is an evidence for this. Instead of the preposition, a clitic, which is an indirect manifestation of oblique case, is used in Central Kurdish. Pronominal clitics are also used in a possessive DP in Central Kurdish such as *kiteb-eke=m* ‘my book’. The fact that (58) can be said in Central Kurdish also attests that Holmberg’s argument is right.

(58)

a. ‘I have you.’

to=m	he-(y)e.	/	he=m-ît.
you-1SG.CL	exist-be.PRS.3SG		exist=1SG.CL-2SG

b. ‘You have me.’

min=it	he-(y)e.	/	he=t-im.
I=2SG.CL	exist-be.PRS.3SG		exist=2SG.CL-1SG

Since the verb is clearly non-agentive, the possessor subject is not theta-marked in the Spec-*v*P. Instead, it is in the Spec-AuxP. Following the assumption in (30), it should be the case that *v* is not a phase head. This explains why object-verb agreement occurs in such a structure. Thus, a schematic structure like the following, which is for the sentence in (55a), will suffice to explain the agreement-and-case pattern of the possessive construction.

(59)

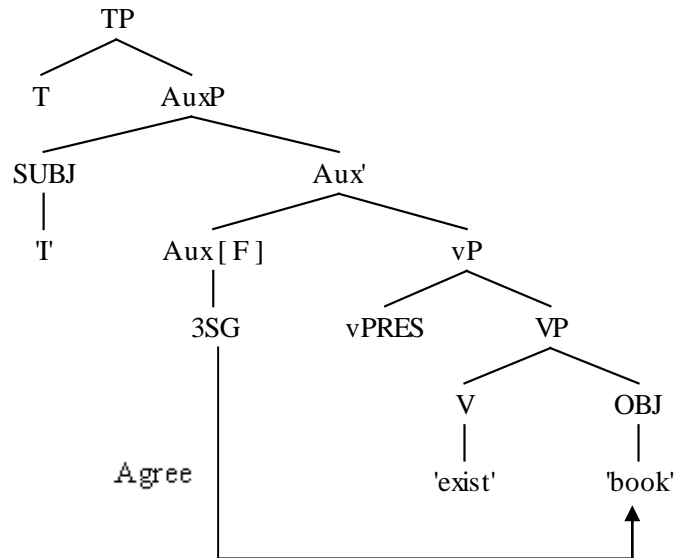

The reason that v_{PRES} cannot block the agreement or serve as phase head is because it cannot theta-mark the subject in its specifier, as is the case with past transitive verbs. The subject moves out to its dedicated subject position, and is doubled by an agreeing pronominal clitic, which represents oblique case indirectly. The verb head moves to pick up its inflections and results in the right morpheme order. In order to bring about the correct OV order, the object via remnant VP movement, moves out to Spec-TP (see section 3.4 for the derivation of verbal complex in Central Kurdish).

4.8.4 *The Want Construction*

Another ergative structure includes the *want-construction*. Like other ergative structures, this construction in Central Kurdish has no phase boundary even in the present tense. As Karimi (2013: 72) claims, the equivalent of the verb ‘to want’ in Central Kurdish ‘is derived from an intransitive verb meaning *to be essential*.’ This necessity verb is clearly non-agentive. As in other dyadic nonagentive verbs, the subject is noticeably not theta-marked in the Spec- vP but rather in the Spec-AuxP, similar to past transitive constructions. As explained above, being an experiencer rather than an agent, the subject gets oblique case; whereas the object (the theme argument) gets direct case (abstract) because it agrees with the finite verb, as shown in (60) below. The agreement is shown in boldface letters.

(60)

min **kitêb**=im de-wê-(ê)t.
I book=1SG.CL IND-want.PRS-3SG
'I want book/books.'

Hence, the agreement-driven analysis provided in this chapter clearly accounts for its ergative agreement (and case) pattern. As shown the schematic structure in (61), the subject is not assigned a thematic role in the Spec-*v*P because the verb is not agentive. Instead, the subject starts out in the Spec-AuxP. The agreement head Aux, probing downward to find a DP to agree with, finds DP object, which is the closest in terms of c-command. Since the verb stem does not constitute a phase, it thus does not block object-verb agreement.

(61)

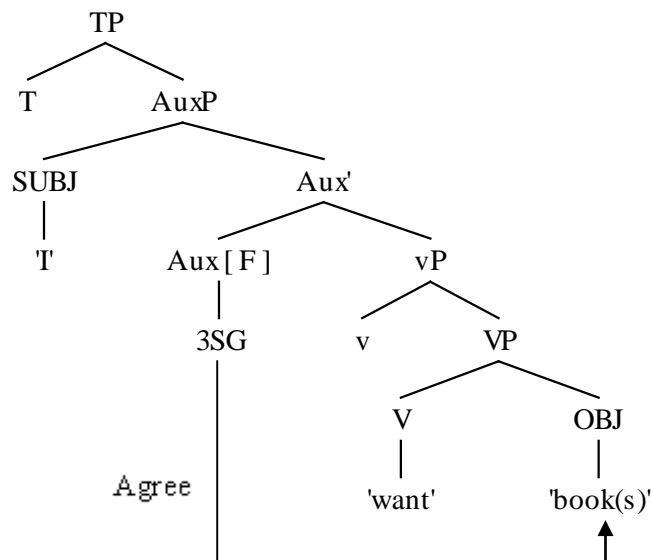

An interesting feature of the verb *wîstin* in Central Kurdish is that it can also be used in light verb construction (complex predicates) meaning ‘to love’. A nominal *xoy* ‘good/pleasure’ is added to the verb to convey such meaning, as can be seen in (62) below. Again, it shows the ergative pattern seen previously. Although the tense of the clause is present, agreement pattern still exhibits an ergative alignment which is the default 3rd person agreement (complex predicates is discussed in more detail in chapter five).

(62)

min to=m xoş de-wê-(ê)t.
I you=2SG.CL good IND-want-3SG
'I love you.'

It is significant to point out that Central Kurdish (as well as Northern Kurdish) has a small number of intransitive predicates with experiencer subjects that do not agree with the verb. The tense of the verb does not affect the agreement pattern, as demonstrated in (63) below. In both tenses, the subject is doubled by an agreeing pronominal clitic.

(63)

- a. min serma=m-e.
I cold=1SG.CL-be.PRS.3SG
'I am cold.'
- b. min serma=m bû.
I cold=1SG.CL be.PST
'I was cold.'

Baker and Atlamaz (in progress: 5) explain that this is also the case in Northern Kurdish, as shown in (64).

(64)

mi sor-e.
I.OBL cold-be.PRS.3SG
'I am cold.'

They explain that the experiencer subject bears quirky oblique case and that the clause lacks a nominative (direct) DP. Since there is no other DP, there is no nominative (direct) DP. In Northern Kurdish, as they argue, there is always a nominative DP where there is at least one argument that does not bear quirky case. In Central Kurdish, there is no morphological case on DP arguments. Thus, this phenomenon is manifest in the use of the pronominal clitics, which are inferred throughout this study to be the indirect manifestation of oblique case. An explanation for this is that the DP having quirky case can prevent the agreement head Aux from agreeing with it, as in standard analyses of Icelandic. In other words, the agreement head cannot agree with the subject when it has

lexically determined case. This is manifest in Northern Kurdish as it has morphological case on its DP arguments. In Central Kurdish, this is manifest in that the subject is doubled by a pronominal clitic.

As far as quirky oblique subjects are concerned, they are only found in monadic predicates. As was seen in (60), the dyadic experiencer predicates have different analysis. The agreement head agrees with the theme argument rather than the subject. The reason for this was that even V_{PRES} is not a phase when it does not theta-mark the subject in its specifier (see the structure in (61)).

4.9 Summary

The agreement-driven approach adopted in this chapter accounts, to a large extent, for the agreement morphemes and the pronominal clitics found within the verbal complex of Central Kurdish. In almost all Kurdish dialects and Iranian languages, there is a stark difference between past and present verb stems. This difference results in the difference in the clausal structure of past and present tense, which is clearly reflected in the crossed agreement (and case) pattern. Being inherently passive in nature due to their historical derivation from past participle, past stems do not constitute phase heads as present stems do. A past stem cannot theta-mark the subject in its specifier; instead the subject in the past is theta-marked in the specifier of a null transitive auxiliary. This results in the agreement head agreeing with the object if there is one, otherwise with the subject via the cyclic agree. Present stems do in fact theta-mark the subject because they are active. Thus, the agreement head in the present tense always agrees with the subject, being the closest c-commanded argument. The crossed-agreement pattern is also seen in contexts where nonagentive verbs such as predicative possession, necessity verbs, some instances of non-volitional states or events, and potentiality expressions are used. Since these verbs cannot theta-mark subjects in their specifiers, they do not constitute phase heads. This, in turn, results in the ergative agreement pattern even in the present tense in which the verb agrees with the object and the subject is doubled by a pronominal clitic in Central Kurdish.

Chapter 5. Complex Predicates

5.1 Introduction

This chapter is mainly concerned with the morphosyntactic characteristics of complex predicates (also known as light verb constructions or compound verbs) in Central Kurdish. In particular, it focuses on the syntax of verbal inflections that are used in this construction, and whether the syntactic analysis for the (simple) verbal predicate proposed in the previous chapters works for complex predicates. Most importantly, it is necessary to determine the syntactic properties of both the non-verbal element and the light verb that constitute such complex predicate constructions. As the chapter focuses on one of the main types of verbs in Central Kurdish, it is shown how the proposed syntactic analysis for verbal inflectional morphemes and agreement patterns in the language fit into the overall TP structure.

This chapter is organized as follows: section 5.2 introduces the general characteristics of complex predicates within syntactic theory. Section 5.3 introduces the construction in Central Kurdish and attempts to find out how the general characteristics of complex predicates apply in the language. Section 5.4 characterizes and distinguishes the different components of complex predicates in the language. In section 5.5, a detailed syntactic analysis for the construction is proposed, focusing specifically on the syntax of light verb and its non-verbal element. Once this is achieved, the focus will be on the verbal inflections used in the construction, which are dealt with in section 5.6. The last section summarises the findings of the chapter.

5.2 General Characteristics of Complex Predicates

As Karimi (2013: 1) defines, complex predicates ‘are structures consisting of more than one element, where each component contributes to the predicate information which is normally associated with a single verb in a language like English.’ In particular, complex predicates, which can also be labelled as light verb constructions, usually consist of a light verb and a non-verbal element. I will henceforth use the abbreviation LV for ‘light verb’ and NV for ‘non-verbal element’. The term ‘light verb’ was first coined by Jespersen (1965: 117) to refer to a class of English verbs that are obviously different from lexical verbs or even auxiliaries. Examples of these light verbs in English include (*take* in *take a*

walk, have in have a rest, give in give a shout). The idea behind using the term ‘light’ was that these verbs *take, have, and give* in the above constructions do not predicate fully. For example, it is not possible that one can physically ‘take’ a ‘walk’ but rather one ‘walks.’ Thus, although these verbs follow the rules of standard verbs in English, they are light in terms of their meaning. That is, these verbs are thought to be semantically lightened and lacking enough thematic force to function independently. Since they have little semantic content of their own, they form a (complex) predicate with some additional expression, which is usually a nominal.

Since Jespersen (1965), many researchers studied and uncovered idiosyncratic characteristics of complex predicates in various languages (Cattel 1984; Kearns 1989; Grimshaw and Mester 1988; Rosen 1989; Sato 1993; Kim 1994; Mohanan 1995; Diesing 1998; Butt 1995, 2003; Butt and Ramchand 2005; among many others). With regard to Central Kurdish, there has been almost no study on complex predicates or light verbs, especially on the syntax of NV elements or the preverbal particles that are used in such constructions. Other dialects of Kurdish such as Northern Kurdish, however, have received some attention (Haig 2002; Karimi-Doostan 1997, 2001). Concerning other Iranian languages, Persian has been studied quite extensively. Complex predicates in this language have attracted wide attention (Vahedi-Langrudi 1996; Karimi-Doostan 1997, 2005; Megerdooian 2001, 2002; Folli *et al.* 2005; among others).

It is worthy of note that the structure of complex predicates (or light verb construction) is slightly different from one language to another. As shown in the following examples in (1), in each language a somewhat different set of components are used in the formation of the construction. In English, it is assumed that an LV plus a DP (e.g., *have a rest* and *take a walk*) constitutes a complex predicate, where LVs in English include *do, make, have, and give* as considered by Jespersen (1965). Grimshaw and Mester (1988) consider the DP-o *suru* construction in Japanese as a complex predicate, with *suru* ‘to do’ a typical LV in Japanese. Diesing (1998) regards DP (indefinite) plus *ton* ‘to do’ in Yiddish to form a complex predicate in the language. In Persian, DP plus LV is considered to be a complex predicate by Karimi-Doostan (1997, 2005) and Folli *et al.* (2005).

- (1)
- a. *English* [LV + DP]
John [took a shower].

b. *Japanese* [DP-o + *suru* (LV)]

John-wa Mary-ni [hanashi-o shita].
John-Top Mary-to talk-Acc suru
'John talked to Mary.'

(Grimshaw and Mester 1988: 207)

c. *Yiddish* [DP(indefinite) + LV]

Ikh vel [a for ton].
I will a travel do
'I will travel a little bit.'

(Diesing 1998: 126)

d. *Persian* [DP + LV]

John ?aroosak-ra be Mary [?ehda: kard].
John doll-SOM to Mary giving do-PST
'John gave the doll to Mary.'

(Karimi-Doostan 2005: 1738)

The phrases inside the square brackets indicate complex predicates in the various languages. As can be seen in the above examples, the surface structures of the complex predicates are slightly different across the languages. In particular, the order of the LV with regard to its complement varies in that it either precedes or follows its complement. This is obviously related to the normal structure of the language; that is, if a language is head-final in the VP, then the NV element precedes the LV.³⁰ Besides, the syntactic categories of the complements are different as well (e.g. a noun or a verb).

There are still some widespread and probably universal characteristics shared in all complex predicates across languages. In the first place, as Bak (2011: 9) labels it, a prominent characteristic of complex predicate is that it is a 'split construction', which means that 'the properties of the predicate splits into two components: the semantic component and the morphological component' (ibid). Principally, the LV is the morphological component in that it is responsible for the verbal morphology, whereas the complement of the LV is the semantic component in that it mostly conveys the meaning of the predicate. In (1a), it is obviously the meaning of the word 'shower' which

³⁰ It should be noted that while most objects in Yiddish can appear post-verbally, NV elements cannot.

contributes essentially to the meaning of the whole predicate ‘took a shower.’ The same is true for all the predicates in (1). The light verb does little by way of adding meaning to the whole predicate. Yet, its presence is definitely needed in order to bear the burden of the verbal morphology. Without the LV, no predicate could have been formed. This is because it is responsible for marking the verbal inflectional morphemes such as tense, aspect, mood, and the agreement features of person, number and sometimes gender. As can be seen in all the examples in (1), it is the LV, not the complement, which is marked with the verbal inflectional morphemes. In (1a), for instance, the tense morpheme is marked on the LV ‘took’ rather than the complement ‘a shower’. Even in some cases where the LV takes a verb as a complement, it is still the LV itself which is marked for verbal inflections.

The second universal characteristic of complex predicate is its ‘monoclausality’ (Bak 2011; Butt 2003). As shown in (1), although the complex predicate can be grouped into two sub-parts, it still produces a mono-clause. In other words, the complement can be a nominal or verbal expression but still the whole construction is considered as one predicate. This characteristic might also be the crucial difference between complex predicates and serial verb constructions, which are typically formed by V-V combinations. As Butt and Lahiri (2013) argue, serial verb constructions cannot be considered as a subset of complex predicates because they typically stack several events in a clause whereas this is not what complex predicates do.

Another general characteristic of complex predicates is related to the restriction on the complement of the LV (Bak 2011: 11). The complement is semantically, morphologically, or syntactically conditioned, which means that it might take a specific form. For example, in Korean complex predicates, the nominal complement of the LV ‘must satisfy a lexical-semantic qualification’ (ibid), specifically, the complement must maintain the feature ‘eventuality’, as shown in the contrast in the following example.

- (2) *Korean*
- | | | | |
|----|------------------|----------|------------|
| a. | Tom-i | wundong | ha-ess-ta. |
| | Tom-NOM | exercise | do-PST-DEC |
| | ‘Tom exercised.’ | | |

- b. *Tom-i chayk ha-ess-ta.
 Tom-NOM book do-PST-DEC
 Intended: ‘Tom finished the book.’ (lit. ‘Tom did the book.’)

(Bak 2011: 11)

The complement in (2b) *chayk* ‘book’ is not an event noun hence the ungrammaticality of the sentence, whereas the complement *wundong* ‘exercise’ in (2a) is clearly an event nominal expression and hence the grammaticality of the sentence. In fact, the restriction on the complement in terms of semantic, morphological, or syntactic is widely found among complex predicates across languages.

The fourth general characteristic of complex predicates concerns the meaning of the LV. As noted above, it is widely considered that the LV has little or no meaning at all. Besides, the number and choice of the LVs across languages are limited. In each language that has complex predicates only a certain number of verbs, which are thought to be semantically bleached and light, can be used as an LV. In English, for example, only several verbs such as *do*, *make*, *take*, *be*, etc. can be used as LV. It is also the case that a certain verb can be used as both an LV and a heavy/lexical verb. The verb *take* can be used as LV as in *take a bath* and a lexical verb as in *take the letter*. This is also true in Central Kurdish and many other languages.

In addition to these general characteristics shared by the languages that have complex predicates, there are some language-specific features of this structure. In the next section, the general characteristics of complex predicates in Central Kurdish are explained.

5.3 Complex Predicates in Central Kurdish

As noted in section 2.3, verbs in Central Kurdish fall into two categories: thematic verbs and light verbs. The majority of the verbal predicates in the language are complex and LVs such as *kirdin* ‘to do’ are used with nouns or other syntactic categories in their formation. As demonstrated in (3), such complex structures consist of an NV element, which could be a noun, an adjective, a preverbal particle, or a preposition, followed by an inflected LV, which has partly or completely lost its original meaning.

(3)

a.	N + LV	<i>ser birîn</i>	[head + cut]	‘to behead’
b.	Adj + LV	<i>amade kirdin</i>	[ready + do]	‘to prepare’
c.	P + LV	<i>ser kewtin</i>	[up + fall]	‘to succeed’
d.	Adv + LV	<i>dreng kewtin</i>	[late + fall]	‘to be late’
e.	PREV + LV	<i>ra-kirdin</i>	[PREV + do]	‘to run (away)’
f.	PP + LV	<i>le dest dan</i>	[from hand + give]	‘to lose’
		<i>le dayk bân</i>	[from mother + be]	‘to be born’

The number of verbs that can be used as LVs is limited, but these constructions are exceptionally productive in Central Kurdish. The most productive of such verbs is the typical LV *kirdin* ‘to do’. Some of the NV elements in (3) are put in example sentences in (4). The NV element is shown in boldface letters.

(4)

- a. **belên** de-de-m.
promise IND-give.PRS-1SG
‘I promise.’ ‘lit. I give promise.’
- b. **ra** de-ke-m.
PREV IND-do.PRS-1SG
‘I run/will run (away).’
- c. Azad ema **sersam** de-k-at.
Azad we astonish IND-do.PRS-3SG
‘Azad (will) astonish us.’
- d. guris-eke **tûnd** de-ke-m.
rope-DEF tight IND-do.PRS-1SG
‘I (will) tighten the rope.’

One morphological characteristic of LVs in Central Kurdish is that verbal inflections such as the mood markers, the negation particle or even the verbal agreement markers can only appear on the LV itself, as the above examples show. This actually reflects the first general characteristics of complex predicates in that the LV is the morphological component of the whole structure. Unlike verbal inflections, the NV elements in this

construction do not seem to have grammatical functions, but they do have semantic function as they combine with the same verb stem to derive different verb meanings. Again, this supports the first characteristic of complex predicate in that the NV element is the semantic component. For example, in (4b) above, the preverbal *ra* has combined with the verb *kirdin* ‘to do’ to coin a new verb *ra-kirdin* ‘to run’. Moreover, the above examples show that complex predicates can be intransitive, e.g. as in (4a) and (4b), or transitive, as in (4c) and (4d).

In addition to the separation of the NV element from the LV by verbal inflections such as the mood markers, the negation particle, or the pronominal clitics, certain nominal NV elements might have a particular reading and seem to function as DP object arguments. These types of nominal NVs can in fact be separated from the LV in some syntactic constructions, as demonstrated in (5). Most importantly, the examples in (5) show that complex predicates cannot be lexical units.

(5)

- a. *terze-(e)ke be baxça-(e)ke=m zîan-î geyand-Ø.*
 hail-DEF to garden-DEF=1SG.CL damage-EZ send-PST-3SG
 ‘The hail caused harm to my garden / The hail damaged my garden.’
- b. *terze-(e)ke zîan-î be baxçe-(e)ke=m gayand-Ø.*
 hail-DEF damage-EZ to garden-DEF=1SG.CL send-PST-3SG
 ‘The hail caused harm to my garden / The hail damaged my garden.’
- c. *terze-(e)ke zîan-êk-î xrap=î be baxçe-(e)ke=m*
 hail-DEF damage-INDEF-EZ bad=3SG.CL to garden-DEF-1SG.CL
geyand-Ø.
 send.PST-3SG
 ‘The hail caused bad damage to my garden.’
- d. *terze-(e)ke-î dwênê zîan-êk-î xrap=î be*
 hail-DEF yesterday damage-INDEF-EZ bad=3SG.CL to
baxçe-(e)ke=m geyand-Ø.
 garden-DEF=1SG.CL send.PST-3SG
 ‘Yesterday’s hail caused bad damage to my garden.’

- e. ew **zîan**-e-î ke terze-(e)ke-î dwene be
 That damage-DEM-EZ that hail-DEF-EZ yesterday to
 baxça-(e)ke=m=î geyand-Ø zor xrap bu-Ø.
 garden-DEF=1SG.CL=3SG.CL send.PST-3SG very bad be.PST-3SG
 ‘The damage that yesterday’s hail caused to my garden was very bad.’

As can be noticed, the nominal NV element (boldfaced in the above examples) can take the indefinite suffix (5c), can be separated from the LV by a PP (5b), can be modified by an adjective via an Ezafe morpheme (5c), and can be relativized (5e). There are also non-nominal NV elements, which can co-occur with DP arguments and cannot be separated by a PP from the LV (as in 6b), and cannot be modified by an adjective (as in 6c).

(6)

- a. Azad ême **sersam** de-k-at.
 Azad we astonish IND-do.PRS-3SG
 ‘Azad will astonish us.’
- b. *Azad **sersam** ême de-k-at.
 Azad astonish we IND-do.PRS-3SG
 ‘Azad will astonish us.’
- c. *Azad ême **sersam-î** baş de-k-at.
 Azad we astonish-EZ good IND-do.PRS-3SG
 ‘Azad will astonish us well.’

It is clear that complex predicates are not merged as lexical units, but are constructed in the syntax by merging the parts separately. The fact that some of them are separable, as was seen in the examples in (5), is consistent with this. Moreover, complex predicates do not all have meanings that are predictable from their parts. This is not something new or surprising as probably all languages have idioms that are formed by combining words into phrases that have more or less unpredictable meanings, sometimes completely unpredictable, as in the case of the canonical *kick the bucket* ‘die’. These idioms or constructs have word-like semantics but are syntactically phrases. The Central Kurdish complex predicates are just a special case of this general phenomenon. Hence, it is necessary to examine the morphosyntactic properties of the components of complex predicates, which are dealt with in the next section.

5.4 The Components of Complex Predicates

In order to understand the syntax of complex predicates in Central Kurdish, it is necessary to uncover the semantic and morphosyntactic properties of the various components of the construction. As noted in the previous section, every complex predicate consists of an LV and an NV element, which can be a nominal, an adjective, an adverb, a prepositional phrase, a preposition, or a preverbal particle. Of particular importance are the different types of nominals used with an LV and the preverbal particles, which are traditionally considered to be verbal inflections. In section 5.4.1 the semantic and morphosyntactic properties of LVs are described in detail, while in section 5.4.2 the different types of NVs are explained and characterized.

5.4.1 *Light verbs vs Heavy verbs*

Grimshaw and Mester (1988) define two specific properties for LVs: (a) they are semantically deficient, and (b) they are either phonologically null, or if overt, they only serve as a host for agreement and tense morphology. These two properties are mostly true for LVs in Central Kurdish, except that they are always overt. In the first place, LVs in Central Kurdish, unless combined with an NV element, do not offer a clear meaning. For example, the verb *kirdin* ‘to do’ as a predicate would not convey a specific proposition unless it is combined with an NV. Nevertheless, there are some ‘heavy’ or lexical verbs, which can also function as LVs in some contexts. These verbs cannot be said to be semantically deficient when they are used as heavy verbs. Secondly, LVs in Central Kurdish, like lexical/thematic verbs, serve as a host for verbal inflections such as agreement, aspect, negation, etc.

Karimi-Doostan (2011: 76) uses a number of criteria to distinguish between heavy verbs and LVs in Persian. These criteria are related to nominalization, the formation of manner adverbials, modification by adverbs, causativisation, and argument structure. Like in Persian, there is an agentive morpheme *-er* in Central Kurdish which is added to the stems of transitive and unergative heavy verbs to form subject nominals, as shown in (7a). LVs cannot take such a morpheme and become subject nominals, as demonstrated in (7b).

(7)

a. Heavy verbs

rûxandin ‘to destroy’ *ruxên-* (stem) + *-er* = *rûxwên-er* ‘destroyer, discourager’

xwêndin ‘to read’ *xwên-* (stem) + *-er* = *xwên-er* ‘reader’

nardin ‘to send’ *nêr-* (stem) + *-er* = *nêr-er* ‘sender’

axawtin ‘to speak’ *axêw-* (stem) + *-er* = *axwê-er* ‘speaker’

b. Light verbs

kirdin ‘to do’ *kir-* (stem) + *-er* = **kir-er* ‘doer’

dan ‘to give’ *da-* (stem) + *-er* = **da-er/der* ‘giver’

birdin ‘to take’ *be-* (stem) + *-er* = **be-er/ber* ‘taker’

However, when the LV is used in a complex predicate context, such an operation is possible. In other words, adding an NV element to an LV makes the nominalization of the stem of the LV possible, as demonstrated in (8) below.

(8) Non-verbal element (NV) + light verb (LV)

Complex predicate: *pena* ‘shelter’ + *birdin* ‘to take’ = *pena birdin* ‘to take shelter/to ask for refuge’

Agentive (subject) nominal: *pena be-(e)r* ‘refugee’

Complex predicate: *şerr* ‘fight’ + *kirdin* ‘to do’ = *şerr kirdin* ‘to fight’

Agentive (subject) nominal: *şerr k-er* ‘fighter’

Complex predicate: *rra* (preverbal particle) + *kirdin* ‘to do’ = *rrakirdin* ‘to run’

Agentive (subject) nominal: *rra k-er* ‘runner’

Thus, if it is allowed to add the agentive *-er* morpheme to the stem of the verb to form an agentive nominal, then the verb is a (transitive or unergative) heavy verb. If this operation is not possible, the verb is an LV. This criterion is a good indicator of whether a verb is a light verb or a heavy verb.

Not all the criteria can be used in Central Kurdish, however. For instance, the formation of manner adverbials from the verb stem is not possible in Central Kurdish. Unlike in Persian, there is no specific morpheme that can be added to verb stems to produce a type of manner adverb. Still, the modification by adverbs is another criterion that can be used

to distinguish between LVs and heavy verbs. As in Persian, LVs, in contrast to heavy verbs, cannot be preceded directly by a modifying adverb, as demonstrated by the ungrammatical example in (9b). The whole complex predicate, however, can be modified by an adverb, as shown in (9a).³¹ Heavy verbs can be directly preceded by an adverb, as in (9c). The adverb is shown in italicized letters whereas the NV element is in boldface letters.

(9)

- a. Azad Sasan=î *xrap* **siza** da-Ø.
 Azad Sasan=3SG.CL bad punish give.PST-3SG
 ‘Azad punished Sasan badly.’
- b. *Azad Sasan=î **siza** *xrap* da-Ø.
 Azad Sasan=3SG.CL punish bad give.PST-3SG
 ‘Azad punished Sasan badly.’
- c. Azad sêw-eke=î *xêra* xward-Ø.
 Azad apple-DEF=3SG.CL fast eat.PST-3SG
 ‘Azad ate the apple fast.’

Another criterion that many researchers (cf. Karimi-Doostan 2011; Grimshaw and Mester 1988; Folli *et al.* 2005) use to distinguish between LVs and lexical verbs is related to the argument structure. In terms of argument structure, LVs and heavy/lexical verbs are different. As Karimi-Doostan (2005, 2011) points out, heavy/lexical verbs normally take a certain number and type of arguments consistently, whereas LVs have unpredictable argument structure. Depending on the NV element, the same LV can take different numbers and types of arguments. For example, the Central Kurdish verb *dan* ‘to give’ typically takes three arguments when it functions as a heavy/lexical verb, as shown in

³¹ In Central Kurdish, it is possible for adverbs to appear in different positions within the sentence. For example, the adverb in (9c) can appear sentence initially or it can precede the direct object, as shown in the following two examples respectively.

- Xêra* Azad sêw-eke=î xward-Ø.
 Fast Azad apple-DEF=3SG.CL eat.PST-3SG
 ‘Quickly, Azad ate the apple.’
- Azad *xêra* sêw-eke=î xward-Ø.
 Azād fast apple-DEF=3SG.CL eat.PST-3SG
 ‘Azad ate the apple fast.’

(10). However, when used as an LV, it can take different numbers and types of arguments, as exemplified in (11).

(10)

Raz	perrtûk-eke=î	be	San	da-Ø.	(Dative)
Raz	book-DEF=3SG.CL	to	San	give.PST-3SG	

‘Raz gave the book to San.’

(11)

a.	Raz	îstîqala =î	da-Ø.	(Intransitive)
	Raz	resignation	give.PST-3SG	

‘Raz resigned.’ ‘lit. Raz gave resignation.’

b.	Raz	San=î	nejat	da-Ø.	(Transitive)
	Raz	San=3SG.CL	rescue	give.PST-3SG	

‘Raz rescued San.’

As can be seen from (11), the argument structure of the LV changes depending on the NV element. Thus, as Karimi-Doostan (2011) and Butt (1995) submit, it is possible to assume that LVs have unspecified or defective argument structure but develops into a complete one once accompanied by an NV element.

In addition, as Megerdooian (2012: 188) argues, there are clearly distinct interpretations with regard to heavy and light verb constructions. As shown in the contrast in (12) below, the different readings point to a difference in structure between predicates with an LV and those composed of a heavy/lexical verb. As is evident in (12a), the nominal in the predicate with the heavy verb corresponds to an entity that undergoes the action denoted by the verb, namely, *xeyar* ‘cucumber’ is being consumed. In contrast, in (12b), the nominal in the predicate with the LV does not correspond to an entity. Rather, it is part of the verbal predicate.

(12)

a.	minal-eke	xeyar	de-xw-at.
	child-DEF	cucumber	IND-eat.PRS-3SG

‘The child is eating cucumber.’

- b. paḫwan-eke şikist=î xward-Ø.
 champion-DEF defeat=1SG.CL eat.PST-3SG
 ‘The champion tasted defeat/was defeated.’

5.4.2 *Non-Verbal Elements*

As noted in section 5.2, depending on the language in question, complex predicates have NV elements of different categories. For example, a specific language might allow only nominal elements to form a complex predicate with LVs. In Central Kurdish, almost all parts of speech can be used with LVs to form complex predicates. As explained in section 5.3, the NV ranges over various elements such as nouns, adjectives, prepositions, adverbials, prepositional phrases, and preverbal (prepositional) particles. In the following, only two of the NV elements, namely, the preverbal particles and nominal elements are characterized and described. This is because other categories such as adjectives do not need characterization. In particular, it is shown how the morphosyntactic properties of the preverbal particles represent other NV elements. Thus, they are considered to be a type of NV element in complex predicates, not a verbal inflection as traditionally thought. With regard to nominals, different types are described and distinguished.

5.4.2.1 Preverbal Particles

There are a limited number of preverbal particles that can be used with LVs to form a complex predicate. In other words, a number of particles can be used with certain LVs to coin new lexical items which are of complex predicate nature. McCarus (2009: 604) believes that there is a closed class of preverbal particles, which are of two sets: ‘inherited prefixes’ and ‘absolute prepositional forms’. However, since prefixes are, by definition, not separated from the stem, I prefer to use the term preverbal particles instead of ‘inherited prefixes’. These function words must be associated with an LV in order to impart meaning, hence they are called particles. Moreover, since the other set are actually prepositions and can occur and function differently in other positions of sentence, they are not considered preverbal particles.

Numbering a dozen or so at most, preverbal particles in Central Kurdish add meaning to LVs or are added to heavy/lexical verbs to modify verbal meanings and create complex predicates. They include some very productive particles such as (*hel* ‘up’, *da* ‘down’, *rra*

‘forth, away’, *rro* ‘down, onto’). These particles are dependent and bound on the verb and cannot occur alone. Though they are very close to the verb stem, they can be separated from it by the negation particle, the pronominal clitics, and the mood markers. Fattah (1997:139) believes that they function as verb particles in English or German. However, unlike the case in these two languages, verb particles in Central Kurdish do not permit words (only clitics or other inflectional morphemes) to set them off from the verb stem. The most obvious function of these particles is that of directional adverb.

The following table, which is adapted from McCarus (2009: 605), shows combinations of preverbal particles plus LVs. The typical LV *kirdin* ‘to do’ can be used with almost all these particles whereas other LVs have limited use with them. For example, LVs such as *çûn* ‘to go’, *hatin* ‘to come’, and *hênan* ‘to bring’ are used with preverbal particles to create complex predicates and coin new verbs.

Table 5.1: Some preverbal particles used with light verbs in Central Kurdish

Particles	Light verbs			
	<i>çûn</i> ‘go’	<i>hatin</i> ‘come’	<i>hênan</i> ‘bring’	<i>kirdin</i> ‘do’
<i>hel</i> ‘up’	‘boil over’	‘rise’ ‘run away’	‘hatch	‘raise’
<i>da</i> ‘down’	‘sag’	‘come down’	‘invent’	‘take off’
<i>rro</i> ‘down’	‘sink down’	_____	_____	_____
<i>rra</i> ‘away’	‘go down’	‘become used to’	‘train, tame’	‘run (away)’
<i>der</i> ‘out’	‘go out’	‘emerge’	‘bring out’	‘expel’

As will be argued in the next section, the morphosyntactic behaviour of such particles is similar to that of other NV elements but different from that of verbal prefixes such as the negation particle or the mood markers.

It is necessary to note that traditional literature on Central Kurdish somehow consider these particles to be part of the verbal inflection. One reason might be related to the orthographic conventions of the language as these particles are spelled as verbal prefixes, bound on the verb stem. Like verbal prefixes, they get the main stress instead of the verb stem, as shown in (13). The stress placement is indicated by boldface letters.

(13)

Azad ała-(e)ke=î **hef** kird-Ø.
Azad flag-DEF=3SG.CL PREV do.PST-3SG
'Azad raised the flag.'

Moreover, these particles host the pronominal clitics. Although prefixes are generally considered not to be separated from their stem, a characteristic of verbal prefixes in Central Kurdish is that they can be separated from the stem by the pronominal clitics, as noted for both the negation particle and the mood markers in section 3.3. This is also true for these preverbal particles. For example, when the direct object *ala-eke* 'the flag' in (13) is not overt but is *pro*, the pronominal clitic, showing agreement with the subject, would be enclitic on the preverbal particle, as shown in (14) below.

(14)

Azad **hef=î** kird-Ø.
Azad PREV=3SG.CL do.PST-3SG
'Azad raised (it).'

Nevertheless, these preverbal particles should clearly not be considered as part of verbal inflections. This is because they are never inflected. Besides, different from verbal inflections such as negation or mood markers, these particles contribute massively to the meaning of the whole complex in general and the verb stem in particular. Most importantly, they are only used with LVs, not with heavy verbs. Hence, if they are verbal prefixes and part of verbal inflections, they should logically be added to heavy verbs as well. The fact that they are only added to certain LVs to coin new words makes them a type of NV elements of complex predicates.

5.4.2.2 Nominals

Unlike other types of NVs whose syntactic categories are straightforward, nominal NVs have various types and are not clear-cut. Depending on the languages with complex predicates, different classifications of nominals have been used. For instance, Karimi-Doostan (2011: 81) divides nominal NVs of complex predicates in Persian according to argument structure, predication, and thematic force. He believes that there are two types:

non-predicative and predicative nominals. Whereas the non-predicative nouns refer to things or objects and do not have argument structure, the predicative nouns refer to events or actions and bear argument structure. The contrast can be shown in (15).

- (15) *Persian*
- a. Non-predicative nouns
- | | |
|-------------|---------------|
| <i>gush</i> | <i>kardan</i> |
| ear | to do |
| 'to listen' | |
|
 | |
| <i>qofl</i> | <i>kardan</i> |
| lock | to do |
| 'to lock' | |
- b. Predicative nominals
- | | |
|--------------|---------------|
| <i>komak</i> | <i>kardan</i> |
| help | to do |
| 'to help' | |
|
 | |
| <i>tahye</i> | <i>kardan</i> |
| providing | to do |
| 'to provide' | |

The reason for such a classification, as Karimi-Doostan (2011: 81) explains, is related to the idea that non-predicative nouns cannot co-occur with arguments in nominal form units when the LV is left out, as shown in (16b). The predicative nouns, however, can co-occur with arguments in such nominal constructions even though the LV can be left out, as exemplified in (17).

- (16) *Persian*
- a. Ali be ra:dyo **guš** da:d/ kard.
 Ali to radio ear give.PST/ do.PST
 'Ali listened to the radio.'
- b. ***guš**-e Ali be ra:dyo.
 Ear-EZ Ali to radio
 'Ali's listening to radio.'

(17)

- a. Ali ka:r-aš-ra: **?anjam** da:d.
Ali work-his-DOM performing give.PST
'Ali did his work.'
- b. **?anjam-e** ka:r tavasote Ali.
performing-EZ work by Ali
'Ali's doing the work. / Doing the work by Ali.'

(Karimi-Doostan 2011: 81)

The so-called non-predicative and predicative nouns seem to behave similarly with regard to argument structure in Central Kurdish. As in Persian, the non-predicative nouns cannot appear in nominal form with arguments predicated by the corresponding complex predicate, as shown in (18b). In contrast, the predicative nouns can actually co-occur with arguments in such nominal constructions where the LV is left out, as demonstrated in (19b).

(18)

- a. Azad **gwê** le radio de-gir-êt.
Azad ear to radio IND-hold.PRS-3SG
'Azad is listening to the radio.'
- b. ***gwê-î** Azad le radio.
ear-EZ Azad to radio
'Azad's listening to the radio.'

(19)

- a. Azad kar-eke=î **enjam** da-Ø.
Azad work-DEF=3SG.CL result give.PST-3SG
'Azad performed the work/task.'
- b. **enjam-î** kar-eke le layen Azad.
result-EZ work-DEF from side Azad
'The result of the work by Azad. / Azad's doing the work.'

However, it seems that there is a problem with this classification. Specifically, there are abstract nouns which refer to events or actions but do not seem to carry argument

structure. Still, such nouns can appear in nominal form units with arguments just like the corresponding complex predicates, as shown in (20).

(20)

- a. minal-eke-an **şerr** de-ke-n.
 child-DEF-PL fight IND-do.PRS-3PL
 ‘The children are quarrelling.’
- b. **şerr-î** minal-eke-an.
 fight-EZ child-DEF-PL
 ‘the children’s quarrel.’

Therefore, a better method of classification for Central Kurdish needs to be related to the status of the nominal. In contrast to the terms non-predicative vs. predicative nouns, I believe that the nominals within the complex predicate in Central Kurdish can be divided into independent and dependent nominals. It seems that the dependent nominals have more characteristics of verbal nouns. Such a classification also proves helpful with regard to the syntactic analysis of the NV elements in section 5.5.2.

In terms of lexical categorization, there are some distributional and morphosyntactic tests that can decide whether a lexical category is a noun or not. Such tests in Central Kurdish are related to pluralization, modification by adjectives, co-occurrence with demonstratives and Ezafe markers, and whether the lexical category can function as subject and object. Accordingly, the dependent nominals cannot be subjected to these tests. For example, the nominal *terxan* in (21) below cannot pass any of these distributional or morphosyntactic tests. In particular, unlike nouns in Central Kurdish, these dependent nominals (verbal nouns) cannot take either the definite marker *-eke* (21b) or the plural marker *-an* (21c), or even the Ezafe marker (21d).

(21)

- a. kompanîa-eke pare-î baş=î terxan kird-Ø.
 company-DEF money-EZ good=3SG.CL allocation do.PST-3SG
 ‘The company allocated a good amount of money.’
- b. *terxan-eke baş bû-Ø.
 allocation-DEF good be.PST-3SG
 ‘The allocation was good.’

c. *terxan-eke-an baş bû-n.
 allocation-DEF-PL good be.PST-3PL
 ‘The allocations were good.’

d. *terxan-î pare-eke baş bû-Ø.
 allocation-EZ money-DEF good be.PST-3SG
 ‘The allocation of the money was good.’

Hence, as can be seen in (21b, 21c, 21d), this type of nominal NV cannot be separated by other materials and cannot be used without the LV in other contexts.

In contrast to dependent nominals, the independent nominals are true DPs which can appear in other contexts and be subjected to and pass the distributional and morphosyntactic tests of nouns. For instance, the nominal *şerr* ‘fight’ in (22) below is used as an NV element of a complex predicate only in (22a). In other contexts, it is used independently of the LV and can thus pass all the noun tests, as shown in (22b, 22c, and 22d).

(22)

a. minal-eke-an şerr de-ke-n.
 child-DEF-PL fight IND-do.PRS-3PL
 ‘The children are quarrelling.’

b. şerr-eke zor=î xayand-Ø.
 fight-DEF very=3SG.CL last.PST-3SG
 ‘The fight lasted long.’

c. şerr-eke-an zor=yan xayand-Ø.
 fight-DEF-PL very=3PL.CL last.PST-3SG
 ‘The fights lasted long.’

d. şerr-î ême dizhî tîrorîst-an-e.
 fight-EZ we against terrorist-PL-be.PRS.3SG
 ‘Our fight is against the terrorists.’

The different types of nominal NVs seem to affect the argument structure of the complex predicate differently. Whereas the dependent nominals, when added to LVs, always form transitive predicates, the independent nominals create different argument structure

depending on the semantics of the noun. In the next section, the syntax of the LV and its various NV elements are discussed.

5.5 The Syntax of Complex Predicates in Central Kurdish

5.5.1 *LVs and little v*

Within the Minimalist framework, transitive verb phrases are constructed as VP shell (or Split VP). That is, it is constructed as a layered VP which consists of the VP (i.e., the lower head) and the *v*P (i.e., the upper head) (Chomsky 1995). Chomsky (1995: 315) calls the upper head within the VP shell ‘little *v*’. He also assumes that LVs in English are realizations of this little *v*. Many studies on LVs in various languages have followed Chomsky in analysing LV as little *v* (e.g. Diesing 1998; Folli *et al.* 2005, among others). It is thus important to find out whether LVs in Central Kurdish share the common characteristics of and can be represented under the category of little *v*.

Since Chomsky (1995), many researchers have studied the concept of little *v* and described its characteristics (Marantz 1997; Harley 1995; Diesing 1998; Arad 1999; Bowers 2002; Cuervo 2003; among others). For example, according to Arad (1999), little *v* has the characteristics summarized in (23).

(23)

- a. Little *v* is a transitive head which introduces the external argument and checks the Case feature of the internal argument.
- b. Little *v* is the verbalizing head which determines the category of the root as verb.
- c. Little *v* comes in several flavours.

Accordingly, the first property indicates that little *v* has two jobs: (i) introducing the external argument and (ii) checking the case feature [ACC] of the internal argument (Chomsky 1995). With regard to Central Kurdish, the external argument starts out in the Spec-*v*P. It is of importance to note that, as argued in chapter four, in Central Kurdish *v* does not theta-mark its specifier in the past tense. Instead, the subject is theta-marked in Spec-AuxP. The reason for this, as argued in section 4.5, is related to *v* being ‘passive in nature’ in the past. Nonetheless, this is not to deny that little *v* is the transitive head which introduces the external argument.

In fact, there is no indication that the LVs in Central Kurdish lack thematic force. In contrast to Karimi-Doostan (2005: 1743), who argues that the Persian, Kurdish, and Korean LVs ‘to do’ do not determine the agent argument in complex predicates, LVs in Central Kurdish seem to determine the agent argument.³² While it seems that ‘to do’ in Persian and even in the Southern Kurdish dialect can be used as an unergative or unaccusative verbal head (as shown in (24a, 24b) and (25a, 25b) respectively), this is not exactly the case in Central Kurdish. The LV ‘to do’ can only be used as unergative (26a), not as unaccusative. To convey the meaning of ‘die’, a lexical verb meaning ‘die’ is used in Central Kurdish, as in (26b), rather than a complex predicate with the LV ‘to do’, as is the case in Persian and Southern Kurdish.

(24) *Persian*

- a. John narmesh kard.
 John exercise do.PST
 ‘John exercised.’
- b. John fout kard/šod.
 John death do.PST/become.PST
 ‘John died.’

(25) *Southern Kurdish*

- a. John narmesh kerd.
 John exercise do.PST
 ‘John exercised.’
- b. John fout kerd.
 John death do.PST
 ‘John died.’

(Karimi-Doostan 2005: 1739)

(26) *Central Kurdish*

- a. John mird-Ø.
 John die.PST-3SG
 ‘John died.’

³² In fact, he refers to a dialect of Kurdish spoken in Kirmanshan and Ilam province in the eastern part of Kurdistan (in the current country of Iran). This sub-dialect can be classified as Southern Kurdish dialect, which is clearly different from Central Kurdish.

- b. John rrahênan=î kird-Ø.
 John exercise=3SG.CL do.PST-3SG
 ‘John exercised.’

Karimi-Doostan (2005: 1742) uses the following tests in (27) from (Chafe 1970; Jackendoff 1990) to differentiate between agent/actor and patient/undergoer arguments. Although such tests might show that Persian LV *kardan* ‘to do’ lacks thematic force, this is not exactly the case in Central Kurdish.

(27)

- a. What x did was ...
 b. What happened to x was ...

It is important to note that Karimi-Doostan only uses verbal nouns, which are referred to in this thesis as dependent nominals, with the LV. In particular, unergative and unaccusative verbal nouns are used with the LV ‘to do’ to test whether all LVs lack thematic force or not. Still, such tests cannot apply to Central Kurdish. This is because, unlike in Persian, it seems the LV *kirdin* ‘to do’ in Central Kurdish can only be used as unergative or transitive. In both cases, the external argument is the agent argument. (28) shows the unergative use of *kirdin* whereas (29) exemplifies its transitive use. As can be seen, the (28b) test of patient argument cannot apply to this LV.

(28)

- a. ewe=î John kirdî ewe bû ke **rrahênan=î** kird.
 What=CL John did what was that exercise=3SG.CL did
 ‘What John did was that he exercised.’
- b. *ewe=î be-ser John hat ewe bû ke **rrahênan=î** kird.
 What=CL on-head John came what was that exercise=CL did
 ‘?What happened to John was that he exercised.’

(29)

- a. ewe=î John kirdî ewe bû ke dergaka=î **qifl** kird.
 What=CL John did what was that the door=CL lock did
 ‘What John did was that he locked the door.’

- b. *ewe=î be-ser John hat ewe bû ke dergaka=î **qifl** kird.
 What=CL on-head John came what was that the door=CL lock did
 ‘?What happened to John was that he locked the door.’

Based on these tests, it is acceptable to maintain that LVs in Central Kurdish can determine the agent argument in complex predicates. However, it is also plausible to claim that NV elements bear thematic properties and are responsible for the number and type of arguments. That is, the choice of the NV element can determine the argument structure of the LV. For instance, when an NV element such as *qifl* ‘lock’ is used with the LV *kirdin* ‘to do’, a transitive LV is formed which needs an internal argument, as in (30a). Yet, when a nominal such as *şerr* ‘fight’, as in (30b), is used with the same LV, it seems that an unergative LV is formed. The only typical LV in Central Kurdish, which is *kirdin*, is thus so semantically bleached that it cannot play a decisive role in determining the argument structure of complex predicates. Instead, the complex NV+LV is the determinant factor.

(30)

- a. min derga-eke=m **qifl** kird-Ø.
 I door-DEF=1SG.CL lock do.PST-3SG
 ‘I locked the door.’
- b. minal-eke-an **şerr**=yan kird-Ø.
 child-DEF-PL fight=3PL.CL do.PST-3SG
 ‘The children quarrelled.’

Thus, as Folli *et al.* (2005) maintain for Persian, while the LV can determine the agentivity of the predicate, it fails to completely determine its argument structure. As a result, depending on the NV element, the same LV may appear in different types of argument structure.

The second property is related to the idea that little *v* has the feature *V* and merges with a category-neutral root to form a verb. The number of lexical verbs in Central Kurdish is very limited and the LVs are predominantly used to coin new verbs in the language. In terms of the idea that little *v* is a verbalizing head, the NV complement should be a category-neutral root rather than a phrase. However, as noted above, the NV elements are sometimes phrases such as DPs or PPs, which clearly do have categorial features. The

question then is whether the NV complements should ever be considered as category-neutral roots rather than phrases.

Thirdly, like in many other languages with complex predicates, little *v* seems to come in various flavours in Central Kurdish. Roots combine with different types of little *v* (Lomashvili 2011; Marantz 1997; Harley 1995; Folli *et al.* 2005) in order to build event predicates, which have different meanings depending on the type or the ‘flavour’ of these little *vs*. As noted above, the typical LV in Central Kurdish is *kirdin* ‘to do’, which is always used as an LV. Other LVs have lexical usage as well and are not semantically bleached like *kirdin*. The different flavours might also be related to the syntactic uses of the LVs in the language. For example, while *kirdin* can be used as transitive LV, *bûn* ‘to become’ can be considered as its intransitive equivalent, as demonstrated in (31).

(31)

- | | | | | |
|----|----------------------------------|-----------------|----------------|------------|
| a. | heþperkê-eke | kiç-eke=î | sersam | kird-Ø. |
| | dance-DEF | girl-DEF=1SG.CL | astonish | do.PST-3SG |
| | ‘The dance astonished the girl.’ | | | |
| | | | | |
| b. | kiç-eke | sersam | bû-Ø. | |
| | girl-DEF | astonish | become.PST-3SG | |
| | ‘The girl became astonished.’ | | | |

To take stock, it is plausible to correlate LVs in Central Kurdish with little *v*. Thus, LVs in the language can be represented under the category of little *v*. That is, they will be represented under the upper verb head in the VP-shell structure. It was also clear that the agentivity of the complex predicate was a characteristic of the LV, not the NV element. What remains is the representation of the NV elements in the overall verbal structure. The status of NV elements also has implications for the overall verbal structure and specifically for the analysis of the verbal inflections and the agreement markers. In the following subsection, the syntax of such elements is presented.

5.5.2 *NV elements and Complex Predicate Structure*

As Folli *et al.* (2005) argue, the syntactic and semantic properties of the NV elements are responsible for the internal event structure of the whole complex, including the number of the internal arguments. However, the mixed properties of the NV elements make it

difficult to present a uniform analysis across the languages. Even within specific languages, the nominal NV element of complex predicates has attracted most attention. Still, there is no uniform analysis even for this specific type of NV. For instance, in Persian, there are disagreements about the status of nominals in complex predicates. Some researchers (e.g. Karimi 1997; Mohammad and Karimi 1992; Pantcheva 2008, 2009) consider these nominals distinct from internal non-specific object arguments in Persian, whereas others (e.g. Ghomeshi and Massam 1994; Vahedi-Langrudi 1996; Samvelian 2001) regard them as non-distinct from bare non-specific object arguments of the verb.

As noted in section 5.3, in Central Kurdish different types of NV elements are used with the LVs. The notion ‘NV element’ ranges over a number of syntactic categories such as nouns, adjectives, prepositions, prepositional particles, and adverbials. It is thus significant to see how such NV elements are positioned within the overall verbal complex structure. Determining the syntax of such elements helps us to see how the verbal inflections interact with them. In order to better understand the morphosyntactic behaviour of these various NV elements, I have divided them into nominal vs non-nominal NVs.

5.5.2.1 Nominal NVs

As argued in section 5.4.2.2, nominal NVs can be divided into independent and dependent nominals. Independent nominals, but not dependent ones, pass the tests of nounhood. The tests are related to pluralization, modification by adjectives, co-occurrence with demonstratives and Ezafe markers, and whether the lexical category can function as subject and object.

On the surface of it, these independent nominals seem to function as the internal argument of the verb whereas the dependent nominals behave differently. In other words, it is possible to suggest that independent nominals within a complex predicate have syntactic properties similar to ordinary object DPs. There is evidence that these DP nominals have characteristics of a direct object of the verb. For example, these independent nominal NV elements can appear as subjects of a passive sentence, as in (32).

(32)

belên de-d-rê-(ê)t.
promise IND-give.PRS-PASS.PRS-3SG
'A promise will be given.'

Another argument is related to verbal ellipsis in negative contrastive focus (also called *not-stripping*). When a DP object is negated under contrastive focus, there is ellipsis of the verb and the sentence is reduced to the focused DP following the negator, as shown in (33).

(33)

gošt de-xo-m, nek masî.
meat IND-eat.PRS-1SG not fish
'I am eating meat, not fish.'

It is interesting to see that such an ellipsis can also be applied to DP nominals in complex predicates, as shown in (34). It should be noted here that the negator in such negative contrastive focus constructions is *nek* 'not'.

(34)

îş de-ke-m, nek siwał.
work IND-do.PRS-1SG not beg
'I am working, not begging.'

Following the terminology that Karimi-Doostan (1997, 2011) proposes to classify Persian complex predicates, it is also adequate to call this type of nominal NV 'separable'. This means that the NV element, which is always an independent DP, can be separated from the LV by other phrases such as PP. In (35), the NV nominal *zîan* 'damage' (shown in boldface letters) is modified by an adjective via the Ezafe morpheme and is separated by a PP from the LV *geyand* 'sent'. While such an NV element seems to function as the direct object of the LV, the PP seems to be the indirect object of LV.

(35)

terze-eke **zîan**-êk-î xrap=î be baxç-eke-m
hail-DEF damage-INDEF-EZ bad-3SG.CL to garden-DEF-my
gayand-Ø.

send.PST-3SG

‘The hail caused a bad damage to my garden.’

Another good piece of evidence for considering such NV element as the internal argument of the LV is to see if it can be relativized. The NV element in (35) can be relativized in which case the whole DP will become the subject of the LV *bûn* ‘to become’, as can be seen in (36) below.

(36)

ew **zîan**-e-î ke terze be baxç-eke-m=î
that damage-DEM-EZ that hail to garden-DEF-my-3SG.CL
geyand zor bû-Ø.

send.PST much be.PST-3SG

‘The damage that hail caused to my garden was too much.’

There can still be some arguments against considering such nominal NVs as the internal arguments of the verb. For example, while true DP objects can be straightforwardly modified by an adjective (as in 37), modifying the nominal NV element of an LV can be problematic, as demonstrated in (38).

(37)

a. birinj-êk-î xrap=man xward-Ø.
rice-INDEF-EZ bad=1PL.CL eat.PST-3SG

‘We ate some bad rice.’

b. kitêb-êk-î baş=im krri-Ø.
book-INDEF-EZ good=1SG.CL buy.PST-3SG

‘I bought a good book.’

c. kemançe-(y)êk-î şaz=im krri-Ø.
violin-INDEF-EZ unique=1SG.CL buy.PST-3SG

‘I bought a unique violin.’

(38)

- a. kutek-êk-î xrap=î xward-Ø.
beating-INDEF-EZ bad=3SG.CL eat.PST-3SG
'He got a bad beating.'
- b. dwênê-şew kemançe-(y)êk-î xoş=im lêda-Ø.
last-night violin-INDEF-EZ good=1SG.CL hit.PST-3SG
'Last night, I played some good violin.'

As can be noticed in (37) examples, via the Ezafe morpheme, the adjective modifies the object DP, not the verbal predicate. However, it seems that the Ezafe modification in (38a) and (38b) modifies the whole predicate, not just the nominal. For example, in (38b) above, it is not the 'violin' that was good, but rather the violin playing that was good.

Another problem is related to question formation. One method of distinguishing between the nominal NV element of a complex predicate and the DP object can be found in the formation of interrogatives. DP objects can be readily questioned. For instance, the DP object in (37a) can be easily questioned, as shown in (39) where the answer to the question is obviously the DP object.

(39)

- çî=tan xward-Ø?
what=2PL.CL eat.PST-3SG
'What did you eat?'
- birinj / brinj-î xrap.
rice / bad rice.

The nominal NV element in complex predicates sometimes cannot be questioned, as demonstrated in (40) below by the formation of an interrogative from nominal element of the LV in (38a).

(40)

- çî=î xward-Ø?
what=3SG.CL eat.PST-3SG
'what did he eat?'

- *kutek / kutek-êk-i xrap.
beating / a bad beating.

This is indeed like English idioms, as exemplified in the following.

Q: What did he kick?

A: ?? The bucket.

It is problematic, then, to assume that the NV nominal can generally function as the internal argument. Being the complement, or the NV element, of the LV does not necessarily mean being the internal argument of the whole predicate. Depending on the argument structure of the whole complex predicate, there can be true internal arguments of the predicate other than the NV nominal. As explained above, the thematic characteristics of these complex predicates depend on the syntactic and semantic characteristics of both the LV itself (the verbalizing head) and the NV element. Even the same (syntactic) type of nouns can be used with the same LV but still two different complex predicates in terms of argument structure can be formed. For instance, the nouns *maç* ‘kiss’ and *şerr* ‘fight’, which both pass the same distributional and morphosyntactic tests, can be used with the same LV *kirdin* ‘to do’ to render two different predicates in terms of argument structure, as demonstrated in the following examples.

(41)

- | | | | | |
|----|--|---------------------------------|-----------------------|--------------|
| a. | kiç-eke=î
girl-DEF=3SG.CL
‘He kissed the girl.’ | maç
kiss | kird-Ø.
do.PST-3SG | (transitive) |
| b. | minał-eke-an
child-DEF-PL
‘The children quarrelled.’ | şerr=yan
fight=3PL.CL | kird-Ø.
do.PST-3SG | (unergative) |

In (41a), in addition to the nominal NV ‘kiss’ there is another nominal ‘the girl’, which obviously functions as the internal argument of the verb. The external argument is not overt in the sentence. Thus, it is manifest that the NV+LV has created a transitive complex predicate. In (41b), there exists only an external agent argument, namely, ‘the children’. The complex NV+LV has thus created an unergative predicate.

Therefore, it seems that LVs are semantically bleached elements that do not affect the argument structure of the verbal predicate. They are, nonetheless, associated with thematic roles such as agent role, as argued above. It is also necessary to point out that the entire semantic content of the complex verb does not come from the nominal element. This is because such an assumption faces a problem when the NV element is an adjectival or adverbial. These non-nominal elements are obviously not associated with thematic roles.

Related to LVs and complex predicates is an original approach to argument structure proposed by Hale and Keyser (1993, 2002). They argue, for example, that verbs in English are composites of an LV and an NV element. Their analysis deals only with three types of NV elements, namely, bare N heads, bare adjectival heads, and prepositional small clauses. Accordingly, denominal and deadjectival verbs can be derived from the following three principal underlying structures (taken from Folli *et al.* 2005: 1372-1373). Folli *et al.* (2005) adopt Hale and Keyser's approach to analyze complex predicates in Persian, and some of their analysis is adopted here in this chapter.

(42)

a. Deadjectival verbs

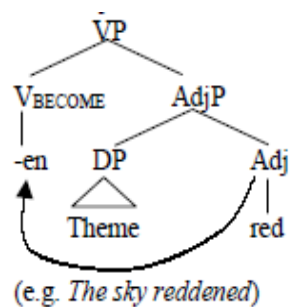

b. Denominal unergative verbs

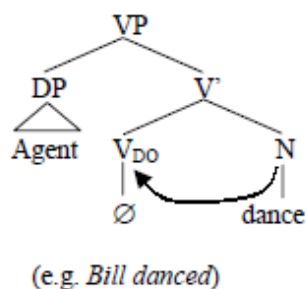

c. Denominal location/locatum verbs

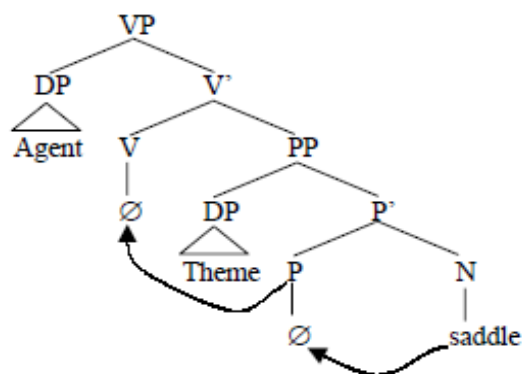

(e.g. *The cowboy saddled the horse*)

Folli *et al.* (2005) believe that each of Hale and Keyser's proposed structures for English verbs in (42) have natural non-incorporated counterparts in Persian complex predicate constructions, where the LV and NV are realized separately. This is the approach adopted here for Central Kurdish albeit some changes are necessary for the analysis of different categories of the NV element, especially with regard to adjectival and prepositional NV elements.

Accordingly, the thematic properties of any particular verb depend on syntactic and semantic characteristics of the composite, namely, the verbalizing head and the NV constituent. A change in either of the composites results in a change in the argument structure of the complex. For example, changing the LV will result in a change in the agent selection, whereas a change in the NV element might result in the change of the argument structure, as was seen in the contrast in (41) above.

Following Folli *et al.* (2005) and Hale and Keyser (1993, 2002), it seems that some of the structures in (42) can naturally translate into Central Kurdish complex predicates. For instance, a complex predicate such as *şerr kirdin* 'to fight/quarrel', exemplified in (41b), can be schematically represented as in the following. Such a predicate can be translated into a typical unergative equivalent in English. Unlike Folli *et al.* (2005)'s analysis in which they label the nominal element as N, I have labelled it as NP. This is because the

NV element is an independent nominal which can pass the distributional and morphosyntactic tests of a noun (see section 5.4.2.2).

(43)

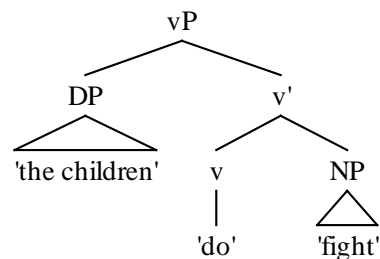

With regard to the transitive complex predicate in (41a), the complement of *v* is analyzed as a small clause in line with Bowers (1993) and A. Áfarli and M. Eide (2002). The example can be compared with English ‘give x a kiss’, which can be analyzed as having the underlying structure ‘MAKE [x GET kiss]’. The head of the small clause is an abstract verb represented by GET, and the whole small clause is the complement of DO, as represented in the following schematic structure.

(44)

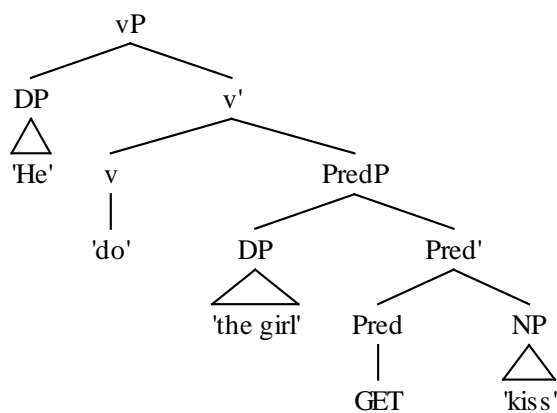

It is interesting to see that an alternative way of saying the same proposition in (41a) is to form a modification structure out of the NV element and the internal argument, i.e., the small clause in the above structure. As can be seen in (45) below, the internal argument can be made into a modifier and be linked to the NV element via an Ezafe morpheme. The Ezafe morpheme can be analyzed as a functional head which links a noun to its modifier, much like a predicate relation between the modifier and the modified (see Karimi (2007) for an analysis of Ezafe morpheme in Central Kurdish).

(45)

maç-î	kiç-eke=î	kird-Ø.
kiss-EZ	girl-DEF=3SG.CL	do.PST-3SG

‘He kissed the girl.’

Thus, representing the internal argument ‘the girl’ as the specifier of a predication projection (PredP) and the NV element ‘kiss’ as its complement seems the right way. This analysis also shows the argument structure property that NV elements can bear.

As noted in section 5.4.2.2, there are dependent verbal nouns that cannot be used as independent DPs. These nominals cannot pass the distributional and morphosyntactic tests of nouns. Besides, unlike separable independent nominal NVs, such dependent nominals cannot be separated from the LV by a PP or any other constituent (except for the verbal inflections, of course). This clearly implies that these nominals are part of the verbal predicate, not an independent constituent from the verb. An important characteristic of this type of nominals is that they can co-occur with a DP object argument, as shown in (46). The NV element is shown in boldface letters.

(46)

ewan	pare-(y)êk-î	baş=yan	terxan	kird-Ø.
they	money-INDEF-EZ	good=3PL.CL	provision	do.PST-3SG

‘They allocated a good amount of money.’

The DP object argument, *pare-(y)êk-î baş* ‘a good amount of money’ is a distinct constituent from *terxan* ‘provision’. This in turn means that the two constituents cannot logically have the same syntactic function. Again, the small clause analysis seems to be the right way to represent the relation between the DP argument and the NV element. That is, there is a predicate relation between the nominal NV element ‘provision’ and the DP argument ‘a good amount of money’. The head of the PredP is represented by an abstract TO. The whole small clause is the complement of the LV ‘do’, and it merges with the LV to form a verbal predicate, denoting a single event, which is in effect equivalent in meaning, and also structure, to a VP headed by a thematic verb. The schematic structure for (46) is represented in (47) below.

(47)

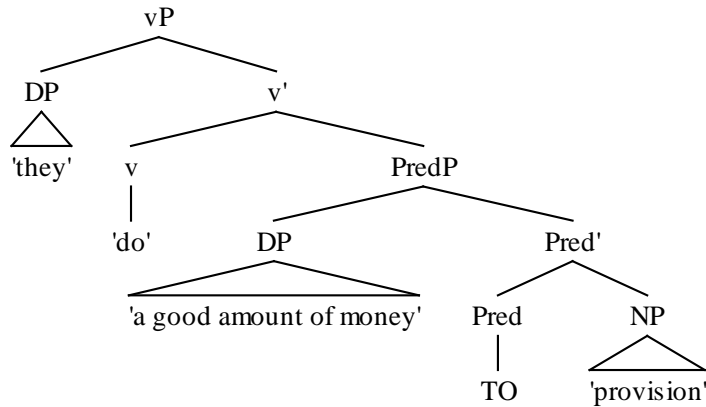

5.5.2.2 Non-Nominal NVs

Beside nominal NVs, there are other elements that form complex predicates with LVs. These elements range over a number of categories such as adjective, prepositions, prepositional phrase, adverbials, and prepositional particles, as demonstrated in (48) below. Similar to nominal NVs, such non-nominal NV elements are components of the verbal predicate.

(48)

- a. Azad kitêb-eke=î **amade** kird-Ø.
Azad book-DEF=3SG.CL ready do.PST-3SG
'Azad prepared the book.' Lit. 'Azad made the book ready.'
- b. minal-eke-an **ra=yan** kird-Ø.
child-DEF-PL PREV=3SG.CL do.PST-3SG
'The children ran (away).'
- c. îş-eke=yan **le dest** da-Ø.
job-DEF=3PL.CL from hand give.PST-3SG
'They lost their job.'
- d. xwêndkar-eke-an **dreng** kewt-in.
student-DEF-PL late fall.PST-3PL
'The students were late.'
- e. jengawer-eke-an **ser** kewt-in.
fighter-DEF-PL up fall-3PL
'The fighters succeeded/won the war.'

In contrast to the ‘separable’ type of NV element, such non-nominal NV elements can be considered as ‘inseparable’. This is because the NV element cannot be separated from the LV by a PP, as can be noticed from the above examples. Note that the term ‘inseparable’ should not be taken literally to mean that the NV element should directly precede the LV and not be linearly separated from it. Rather, in all cases, verbal inflectional morphemes, such as the indicative mood maker *de-* and the negative marker *ne-* can be attached to the verbal element of the phrase. In every case these affixes modify the whole phrase, not its individual constituents. Since they are verbal inflections, they should reasonably be attached to the verb stem (see the examples in (4)).

The type of the NV element, specifically whether it is nominal or non-nominal, determines the structural difference with regard to the complement of *v*.³³ In the expressions discussed in section 5.5.2.1, the complement of the *v* was a noun (when the predicate is intransitive) or a small clause (PredP) taking a DP in its specifier (when the predicate is transitive). Again, in line with Bowers (1993) and A. Áfarli and M. Eide (2002), I suggest a small clause analysis for the adjectival NV element complements. In other words, when the NV element is non-nominal, the complement of the *v* seems to be a small clause headed by syntactic categories other than V. In particular, an abstract TO is the predicative head of the small clause. Hence, an inchoative predicate such as *sersam bûn* ‘astonish become’, exemplified in (31b) and repeated here as (49a), can be analyzed as a clause PredP headed by an abstract preposition, a ‘Pred’, taking an AP complement, as shown in the schematic structure in (49b).

(49)

- a. kiç-eke **sersam** bû-Ø.
 girl-DEF astonish become.PST-3SG
 ‘The girl became astonished.’

³³ The choice of the NV element also affects the Aktionsart and the event structure of the whole predicate, as argued by Folli *et al.* (2005) for Persian. This will not be discussed further here.

b.

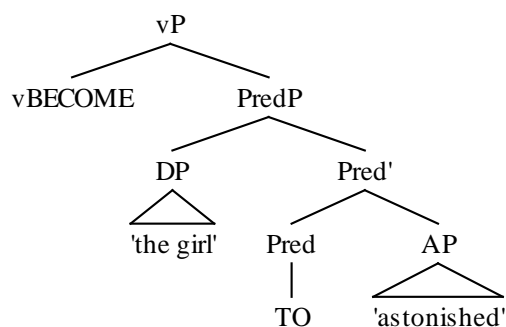

(48d) can also have the same structure. The adjective ‘late’, though functions as an adverbial, establishes a predicate relation with the theme argument ‘the students’. This is shown in (50) below.

(50)

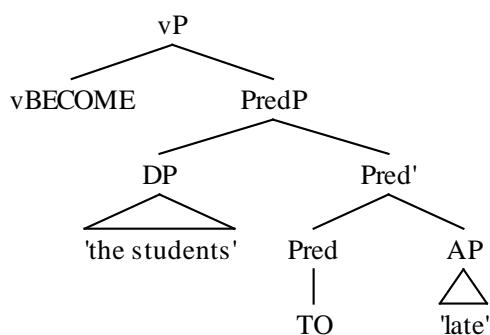

As argued by Folli *et al.* (2005), the LV is responsible for the presence or absence of an external argument. Hence, when the inchoative verb in (49a) is changed into a causative one, the causative alternation is achieved by a different LV, namely *kirdin*, which can be interpreted as ‘make’ here. Consider (30a), repeated here as (51a): the external argument, which in this case has the role of instrument, is introduced in the Spec-vP.³⁴ This causative example can have the schematic structure in (51b). The example in (48a) also represents a causative LV and can basically have the structure like the one in (51b) as well.

³⁴ In fact, as argued in chapter three, external arguments in the past tense are assumed to be generated in Spec-AuxP, instead of Spec-vP. For reasons of exposition, this assumption is not shown in the structure here. However, in the later sections when discussing the agreement pattern within complex predicates, the agent and instrument arguments are represented under Spec-AuxP in the past tense.

(51)

- a. hełperkê-eke kiç-eke=î sersam kird-Ø.
dance-DEF girl-DEF=1SG.CL astonish do.PST-3SG
'The dance astonished the girl.'

b.

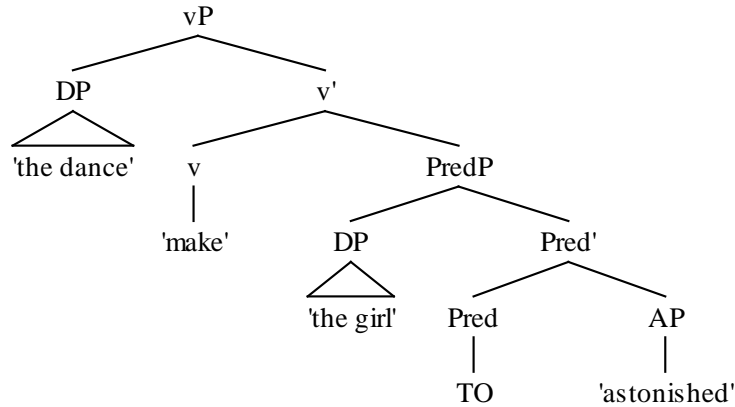

With regard to prepositional NV elements, as in the examples of (48c and 48e) above, the complement of the *v* is a prepositional small clause in line with the analysis offered for the adjectival NV element. However, there is no reason to assume an abstract TO in these examples. This is because it is not semantically correct. Thus, it is assumed that the small clause complement of the LV is headed by an abstract BE. This is somehow different from Folli *et al.* (2005)'s analysis. They extend Hale and Keyser's structure for denominal location verbs to complex predicates with a prepositional NV element in Persian, as was seen in the structure (42c). The small clause analysis adopted here offers a better alternative in that it captures the predicate relation between the DP argument and the NV element. Thus, an intransitive predicate such as (52a) can have the schematic structure in (52b) in which the PredP is headed by an abstract BE. It should be noted that the LV BECOME takes only clausal argument.

(52)

- a. minał-eke le dayk bû-Ø.
child-DEF from mother become.PST-3SG
'The child was born.'

b.

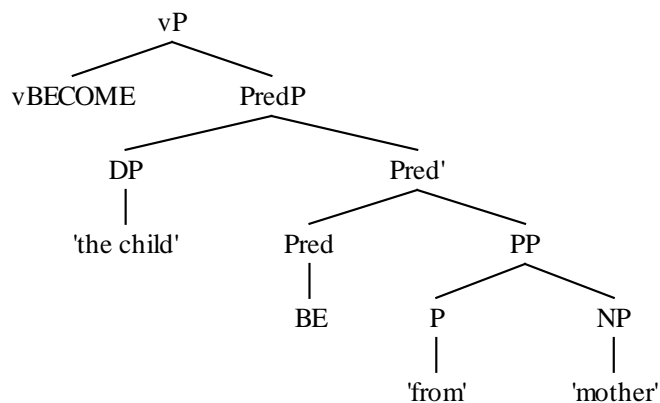

A transitive complex predicate such as (48c), repeated here as (53a) for convenience, has an internal argument plus the prepositional NV element. Like the intransitive example in (52a), the prepositional NV element is analyzed as a small clause headed by an abstract BE, as shown in the structure in (53b).

(53)

- a. $\hat{\text{i}}\text{\textasciitilde}\text{eke}=\text{yan}$ le dest da- \emptyset .
 job-DEF=3PL.CL from hand give.PST-3SG
 'They lost their job.'

b.

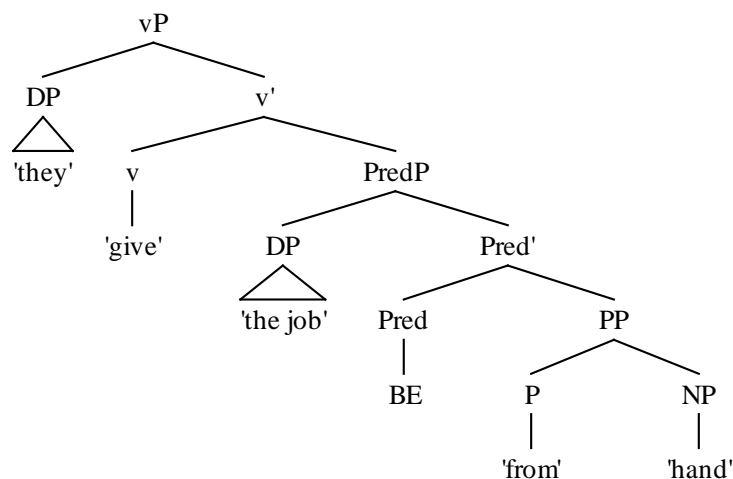

In cases where only a prepositional particle instead of a full PP is used, as in (48e), the structure is still the same as in (52b) and (53b) minus the nominal complement of the P.

A remarkable point can be made with regard to the example in (48b), repeated here as (54) for convenience.

(54)

minal-eke-an ra=yan kird-Ø.
 child-DEF-PL PREV=3SG.CL do.PST-3SG
 ‘The children ran (away).’

Although traditionally preverbal particles are considered to be prefixes, this assumption is apparently not correct, as briefly argued in section 5.4.2.1. One piece of evidence, among some others, for the incorrectness of this assumption is related to the agreement pattern, which is interestingly ergative in that the subject is doubled by a pronominal clitic. The LV *kirdin*, being unergative in this example, follows the past transitive agreement pattern, namely, the ergative agreement. Yet, the example does not translate into a transitive sentence in English; rather, it translates into an unergative one. It seems, unusually, that the LV sees the verbal particle as a nominal NV element. Interestingly though, the meaning of the particle *ra* seems to be derived from the word *rê*, which means ‘path’. Hence, the literal meaning of the complex predicate seems to be ‘take a path’.

I thus suggest an analysis somewhat close to the one proposed for nominal NV elements. In particular, such NV elements are not analyzed as small clause structure. The NV element is seen as a PP headed by an abstract preposition whereas the particle can be seen as the nominal element. In essence, almost all preverbal particles have directional adverbial meaning. Thus, they can be considered as nominals, like the word ‘home’ in ‘I went home’, which obviously have adverbial function. There are good arguments that ‘home’ comes with an abstract preposition ‘to’ (see Collins 2007), as shown in the schematic structure in (55) below, which is for the sentence in (48b).

(55)

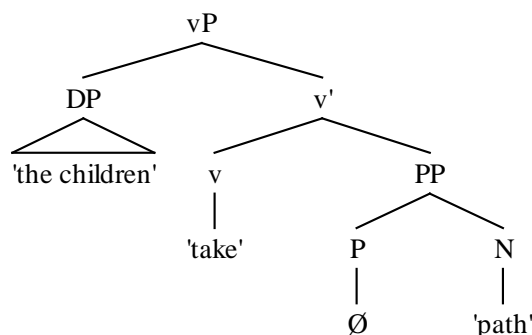

5.6 Verbal Inflections and Complex Predicates

As explained in chapters two and three, verb stems in Central Kurdish take both prefixal and suffixal morphology. The verbal prefixes, namely, the negative particle and the mood markers, are presumed to occupy positions high in the structure. In particular, it was argued that these inflectional markers and the verb stem represent syntactic heads that have not moved with respect to each other. The prefixes are the spell-out of heads that are in higher positions than the stem they combine with. Concerning the verbal suffixes, it was argued that head movement is the right mechanism for their derivation. The suffixes occupy positions lower than the prefixes but higher than the verb stem. The verb stem head-moves to pick them up. Although the derivation of the verbal inflections and the structure proposed in chapter three worked fine with simple thematic verbs, it remains to be seen whether the same analysis works for complex predicates with LVs. It is also important to see whether the analysis proposed for agreement morphemes in chapter four works for complex predicates or not.

5.6.1 Prefixal Morphology in Complex Predicates

As noted in section 2.4.1, negation in Central Kurdish is conveyed morphologically rather than periphrastically. A negative morpheme is positioned before the inflected verb. As was the case with thematic/lexical verbs, the four variants of the negative morpheme can also be used with inflected LVs, as demonstrated in (56). The choice of the negative variant depends on grammatical conditions such as aspect, tense, and mood.

(56)

- a. minal-eke-an şerr na-ke-n.
child-DEF-PL fight NEG-do.PRS-3PL
'The children are not quarrelling.'
- b. minal-eke-an şerr=yan ne-kird-Ø.
child-DEF-PL fight=3PL.CL NEG-do.PST-3SG
'The children did not quarrel.'
- c. şerr me-ke-n!
fight NEG-do.PRS-3PL
'Don't quarrel!'

- d. kitêb-eke amade ni-e.
 book-DEF ready NEG-be.PRS.3SG
 ‘The book is not ready.’

Being the morphological component of the complex predicate, the LV takes the negative morpheme exactly like the way a thematic/lexical verb does. Occupying a position higher than the TP, the negation particle is clearly a head that is higher than the LV and thus ends up as a prefix in the surface order.

With regard to the mood markers, LVs, just like simple lexical verbs, take these inflectional markers. The indicative mood marker *de-* is used with LVs to convey indicative mood in the present and past tense. As exemplified in (57), the use of such a marker with LVs, as in (57b) is no different from its use with lexical verbs, as in (57a).

(57)

- a. kebab de-xo-m.
 kebab IND-eat.PRS-1SG
 ‘I eat/am eating kebab.’
- b. minaŋ-eke-an şerr de-ke-n.
 child-DEF-PL fight IND-do.PRS-3PL
 ‘The children quarrel/are quarrelling.’

Other mood markers include the subjunctive and imperative markers, which are both represented by the prefix *bi-*. Again, the use of such inflectional markers with LVs is no different from their use with simple lexical verbs, as shown in (58).

(58)

- a. eger şerr bi-ke-n,
 if fight SUB-do.PRS-2PL
 ‘if you quarrel,’
- b. bi-ke-Ø!
 IND-do.PRS-2SG
 ‘Do it!’

5.6.2 Suffixal Morphology in Complex Predicates

Like prefixal morphology, the suffixes can also be added to LVs without any difference from their use with lexical verbs. For example, as is the case with lexical verb stems, there is no tense morpheme added to LVs. In other words, the stem of LVs does not contain any tense morpheme or feature. Still, the various tense-aspect distinctions can be expressed within complex predicates. Passive is another suffix that is added to verb stems in Central Kurdish. Transitive complex predicates can be made passive by adding a passive suffix to the stem of the LV, as shown in (59) for passive in the past and present tense.

(59)

- | | | | |
|----|--------------------------------|-------|-------------------------|
| a. | kitêb-eke | amade | de-k-rê-(ê)t. |
| | book-DEF | ready | IND-do.PRS-PASS.PRS-3SG |
| | ‘The book will be made ready.’ | | |
| b. | kitêb-eke | amade | k-ra-Ø. |
| | book-DEF | ready | do.PRS-PASS.PST-3SG |
| | ‘The book was made ready.’ | | |

The perfect aspect is another inflectional morpheme which can be added to the past stem of the LV to form participle. This suffix $-\hat{u}$ is added to the past stem of the verb to form past participle. Thus, the LV *kirdin* ‘to do’ can become *kird-û* ‘have done’.

Hence, it is interesting to see that all these suffixes behave exactly the same with respect to LVs as they behave with lexical verbs. As we have seen the structure for the complex predicates in the previous section, it is now time to see if such structure holds with regard to verbal prefixal and suffixal morphology. The structure proposed in chapter three with regard to verbal inflections looked like the schematic structure in (60) below. As argued in section 3.4, the prefixes and suffixes are derived by two different mechanisms. As is evident in the below structure, the prefixes occupy positions high in the structure and thus represent syntactic heads that do not move with respect to the verb stem. The suffixes occupy positions lower than the prefixes. The verb stem head-moves to pick them up. Such a movement is motivated by the fact that these functional heads are bound

morphemes and need a lexical category to be associated with. Being verbal inflections, it is the verb stem that performs the movement.

(60)

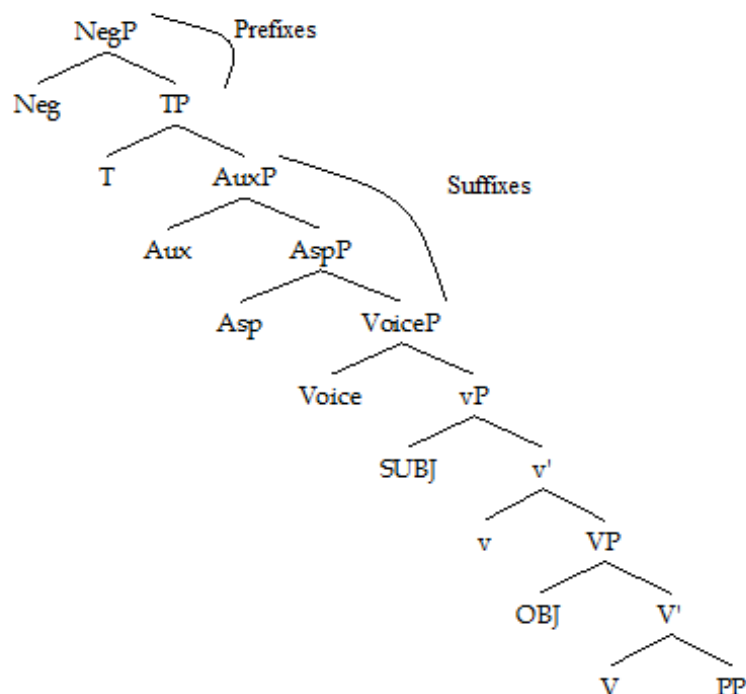

In case of an LV, the situation is not different. The LV, as the highest (overt) head in the predicate, head-moves to pick up the suffixes. The prefixes, on the other hand, remain in their high positions, and therefore, because they are morphologically bound morphemes, end up as prefixes in the surface order. It is significant to note that although there can be a number of inflectional morphemes attached to the verb stem, the derivation does not face any problematic issue. That is, the morpheme order will always be correctly derived, following the theoretical assumptions made in chapter three, together with the underlying structure postulated for clauses in Central Kurdish.

Concerning the status of the NV element and its behaviour with respect to verbal inflections, remnant VP movement is the right mechanism to derive OV order with lexical verbs as well as NV-LV order in complex predicates. For example, NV-LV order of an example like (41a), repeated here as (61a), is derived schematically as in (61b). The subject moves out to the dedicated subject position, Spec-SubjP, as noted in chapter three. Once the abstract head moves to v , it should be the case that PredP is seen as a remnant

category, which moves to the Spec-NegP, the highest head within the functional projections.

(61)

- a. kiç-eke=î maç kird-Ø.
 girl-DEF=3SG.CL kiss do.PST-3SG
 ‘He kissed the girl.’

b.

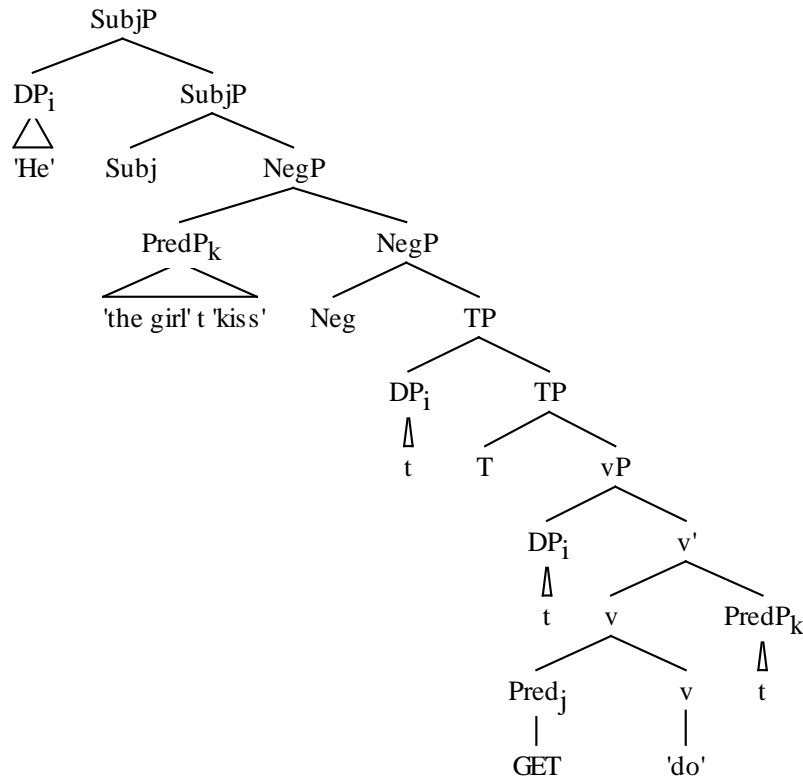

It remains to be seen how the agreement morphemes behave within complex predicates, especially with regard to the status of nominal NV elements and the overall argument structure. In the next subsection, the agreement pattern within complex predicates is dealt with.

5.6.3 Agreement Pattern in Complex Predicates

As argued in section 4.5, the difference in the phasal status of *v* results in the difference in the structure between present and past tenses. The different agreement pattern between clauses with past tense and present tense is also related to the status of *v* and the theta-marking position of the subject. It was argued that the subject in past tense clause is not

theta-marked in the Spec-*v*P but in Spec-AuxP, whereas in the present tense it is in Spec-*v*P. The agreement head *Aux*⁰ thus probes downward to find a c-commanding DP to agree with. In past transitive clauses, the agreement head finds the object DP inside the VP to agree with, prompting ergative agreement pattern. This is possible because *v* is not a phase in the past and thus agreement is not blocked by PIC, and the subject is theta-marked in Spec-AuxP. In past intransitive clauses, the probing functional agreement head finds no goal to agree with. Instead, it probes upward through cyclic agree and agrees with the subject. In the present tense, the agreement head, in probing downward, always finds the subject, which is theta-marked in Spec-*v*P. Being a phase head, agreement with the DP object in the present is blocked by PIC. Thus, agreement in the present tense in Central Kurdish is always with the subject.

As explained above, one of the core components of complex predicates is the NV element. Besides, the argument structure within complex predicates seems different from that within simple predicates. It is thus important to see how the agreement pattern unfolds within complex predicates. As can be seen in the following example, although the argument structure translates into an unergative in English, it is interesting to see that the agreement pattern actually follows the ergative pattern, similar to past transitive clauses.

(62)

minał-eke-an	şerr=yan	kird-Ø.
child-DEF-PL	fight=3PL.CL	do.PST-3SG
‘The children quarrelled.’		

It is manifest that the subject is doubled by an agreeing pronominal clitic, which is attached to the NV element. In essence, the clitic represents oblique case and object in the present tense. Like object-verb agreement in the past transitive simple predicates, the LV seems to agree in number with the NV element, perceiving it as its internal argument. As shown in the schematic structure in (63), an explanation for such an agreement pattern is that the agreement head *Aux*⁰, in probing downward to find a c-commanding DP to agree with, finds the nominal NV element of the LV, which is taken to be its complement. The irrelevant projections are left out.

(63)

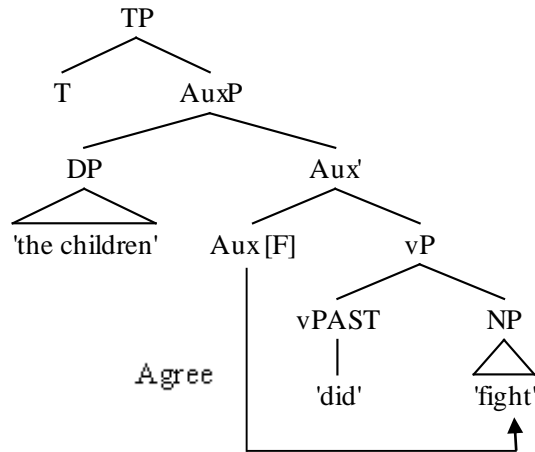

Although the object agreement in this structure is not as clear as it is in past transitive clauses, the assumption still seems to hold. Unlike true DP objects, an NV element cannot be made into a pronominal, though.

Another notable aspect of the agreement pattern in complex predicates is related to the preverbal particles. As noted in section 5.5.2.2, the preverbal particles are traditionally thought to be verbal inflections. Such an assumption, however, is wrong. Since they have the meaning of directional adverbials and do not have a specific grammatical function like that of other verbal inflections, they are thus analyzed as prepositional NV elements in which the preposition is considered empty and the particle is seen as the nominal element of the PP. An example like (48b), repeated here as (64) for convenience, has an ergative pattern where the subject is doubled by a pronominal clitic attached to the preverbal particle. The object-verb agreement is, however, not as apparent as in past transitive clauses.

(64)

minal-eke-an **ra**=yan kird-Ø.
child-DEF-PL PREV=3SG.CL do.PST-3SG
'The children ran (away).'

Although the complex predicate translates into an ergative verb in English, its agreement pattern follows that of past transitive verbs. The reason for this agreement pattern seems related to the idea that the agreement head Aux^0 , in probing downward for a possible DP to agree with, finds the particle. Evidence for such an assumption is offered by the

agreement pattern in the present tense. If the past tense of the sentence in (64) is changed into present, the alignment pattern changes into an accusative one where the verb agrees with the subject in person and number via an agreement suffixal marker on the verb stem, as shown in (65) below.

- (65)
- | | | |
|--------------|-----------|------------|
| minał-eke-an | ra | de-ke-n. |
| child-DEF-PL | PREV | do.PRS-3PL |
- ‘The children are running (away).’

It is obvious that the agreement pattern follows that of a present tense, be it a transitive or intransitive clause. As argued in section 4.6, the tense of the verb is the determinant factor in the difference between the clausal structure and the agreement pattern of the whole predicate. When the clause is past, the subject is theta-marked in Spec-AuxP rather than Spec-*v*P (see chapter four for a detailed explanation), and the agreement head Aux^o probes downward to find a possible DP object to agree with. In transitive clauses, the agreement head finds the object DP to agree with, prompting ergative agreement pattern in the language. Hence, in (64) above, the agreement head seems to find the particle to agree with, always prompting ergative agreement pattern in the past tense of such complex predicates.

What these findings suggest is that the agreement pattern in complex predicates behaves syntactically as in simple predicates in that the tense of the clause is the determinant factor. While the two constituents of a complex predicate, namely the LV and the NV element, join to compose one single predicate syntactically and semantically, the agreement head sees the nominal NV elements as the internal argument of the LV to agree with.

5.7 Summary

It was shown in this chapter that the proposed analysis for simple predicates can also, to a large extent, be applied to complex predicates. The LVs, which are very productive in Central Kurdish, were represented under the category of little *v*. There was no indication that LVs lack thematic force. It was manifest, for example, that LVs in Central Kurdish can determine the agent argument in complex predicates. However, it was also claimed

that the NV elements bear thematic properties and are responsible for the number and type of arguments. Thus, it was argued that the complex LV+NV together determine the argument structure of the whole predicate. Besides, the NV elements, which range over a number of syntactic categories, were analyzed and characterized accordingly within the overall verbal structure of the language. The syntactic analysis for the various verbal affixes proposed in the preceding chapters could also be applied to complex predicates in the language without any ramification. Most importantly, it was shown that the analysis for the agreement pattern proposed in the previous chapter can actually be supported further by arguments from the analysis of NV elements within complex predicates.

Chapter 6. Conclusions

This thesis has been concerned with the syntax of the various verbal inflections in Central Kurdish, focusing on the syntactic structure of clauses in the language. It particularly aimed to provide a comprehensive characterization and description of the inflections found within the verbal of complex of the language and put forward a syntactic account from a generative perspective. Since Central Kurdish is an understudied language, especially within the generative framework, this study has provided the first account of a number of syntactic issues in the language.

Chapter two characterized the verbal morphology in the language. Without such a groundwork description and characterization, the syntactic analysis of the verbal inflections proposed throughout this study was not possible. The chapter basically resolved a number of incorrect assumptions made within literature on the language. It argued that the verbal morphology does not contain as many as seven suffixes, as is common in a number of traditional studies on Central Kurdish. Some of the perceived suffixes were argued to be different forms of auxiliary 'be', which is used to convey various tense-aspect-mood distinctions especially in past tense. Concerning the verbal prefixes, it was manifest that there are only two verbal prefixes in the language. The preverbal particles, which are used in creating new verbs, are not considered to be a verbal inflection and their status and syntax were dealt with in the chapter on complex predicates in the language. Meanwhile, although the verb stem is always either in the present or past stem form, no specific tense morpheme is suggested for the language. Still, the various tense-aspect-mood distinctions could be found. Particularly, it was observed that the auxiliary 'be' plays a significant role in a number of verb forms such as perfect aspect and subjunctive forms.

Chapter three aimed to propose an account of the structure of verbal complex and clause structure in the language. It is argued that the affixal verbal inflections represent functional categories in the language in that they belong to syntactic projections. However, since these affixal inflections include both prefixal and suffixal morphology, Central Kurdish can actually present a hard puzzle with regard to the incorporation analysis of morphologically complex verbs. This is because there are different mechanisms for deriving the complex words within syntactic theory; and each of these mechanism corresponds to different types of affixes. Still, it was established in this

chapter that the verbal affixes in Central Kurdish have different morphosyntactic and phonological characteristics. The verbal prefixes, which are primarily the mood markers and the negation particle, are modals and have different phonological properties from the suffixal morphemes. Such a difference implies that there should be two different methods of derivation for the verbal affixes in the language. Hence, it was established that the verbal prefixes do not directly enter the derivation with the verb syntactically and that they occupy heads that are higher than the verb and the suffixes in the structure. This is indeed one possible way of deriving prefixes within complex words in which the prefix can originate immediately to the left of the lexical element without any subsequent movement operation of any of the two elements. The prefix is simply the spell-out of a head that is in a higher position than the stem it combines with. This is true for the verbal prefixes in Central Kurdish. With regard to the suffixes, it was shown that they occupy syntactic positions between the lexical verb and the prefixes. Head movement mechanism, which creates a complex out of a lexical element and one or more elements from the functional domain of that lexical element, proved to be the means of derivation for the verbal suffixes in the language. Moreover, the external and internal arguments are shown to occupy surface positions that are higher than the verbal functional categories. In particular, it is assumed that the subject DP argument occupies the specifier of specific subject position within the Infl or CP domain. The OV order is achieved via remnant VP movement. Once the verb moves out from the VP to pick up its inflections, the VP becomes a remnant category. This remnant category moves to the specifier of the highest functional projection, namely NegP, to bring about the right word order of the arguments and the verb in the verbal domain in Central Kurdish.

Chapter four dealt with an important aspect of the syntax of Central Kurdish, namely, the verbal agreement. An agreement-driven approach is adopted which accounts essentially for the agreement morphemes and the pronominal clitics found within the verbal complex of the language. The analysis proposed in this chapter makes strong and correct prediction that almost all Kurdish (and even other Iranian) languages can have the same crossed agreement system with or without having the same case system, as long as the difference between past and present verb stems is maintained. It is argued that in almost all Kurdish dialects and Iranian languages, there is a stark difference between past and present verb stems. This difference in the clausal structure of past and present tense, which is clearly reflected in the crossed agreement (and case) pattern, is due to the difference between

past and present verb stems. Due to being intrinsically passive in nature because of their historical derivation from past participle, past stems are considered not to constitute phase heads. Besides, it is maintained that past stem cannot theta-mark the subject in its specifier; instead the subject in past tense clauses is theta-marked in the specifier of a null transitive auxiliary. This results in the agreement head to agree with the object if there is one, otherwise with the subject via the cyclic agree. And, this is basically the explanation for the ergative agreement pattern in the past tense. On the other hand, being active, present stem does indeed theta-mark the subject in its specifier. Hence, the agreement head in the present tense always agrees with the subject, being the closest c-commanded argument. Such an approach accounts for the syntax of verbal agreement markers in which they are always suffixed to verb stem to show either object-verb agreement or subject-verb agreement depending on the tense of the clause.

The crossed-agreement pattern is also attested in contexts where nonagentive verbs such as predicative possession, necessity verbs, some instances of non-volitional states or events, and potentiality expressions are used. Due to the fact that these verbs cannot theta-mark the subject in their specifiers, they do not constitute phase heads. This, in turn, results in the ergative agreement pattern even in the present tense in which the agreement head agrees with the object and the subject is doubled by a pronominal clitic.

Chapter five was concerned with complex predicates in which light verbs play a very productive role in their formation. It is established that the analysis proposed throughout the study for simple predicates (predicates with thematic verbs) can actually be applied to complex predicates. A significant aspect of complex predicates is related to the status of both components of the construction which are the light verb and the non-verbal element. The light verb is argued to be a representation of little *v*. There is no indication that light verbs lack thematic force. Instead, they determine the agent argument in complex predicates. Nevertheless, it is argued that the non-verbal element, which ranges over a number of categories such as nouns, adjective, and prepositions, bears thematic properties and is responsible for the number and type of arguments. Accordingly, it is concluded that the composite of the light verb plus its non-verbal element jointly determine the argument structure of the whole predicate. With regard to the syntactic account of the non-verbal elements, it is shown that almost all of them (nominal, adjectival, or prepositional) can be analyzed as a small clause complement of the light

verb. The small clause, represented by Predication Projection (PredP), has a proliferation of abstract heads. In particular, the transitive complex predicates with nominal non-verbal element is analyzed as small clause whose head is an abstract verb GET and the internal argument of the whole predicate is represented in the specifier of the small clause (PredP). The small clause analysis is also suggested for the adjectival and prepositional non-verbal element complements. Whereas the head of adjectival small clause is assumed to be an abstract TO, the head of prepositional small clause is assumed to be an abstract BE. Except for preverbal particles and intransitive nominal non-verbal elements, the small clause analysis is the syntactic account presented for the non-verbal elements of complex predicates in Central Kurdish.

Moreover, the syntactic account proposed for the various verbal affixes throughout this study could also be applied to complex predicates in the language without any ramification. It was found that the agreement pattern within complex predicates is not dissimilar to that of simple predicates. Most importantly, the agreement-driven approach proposed for the agreement pattern of the language can actually be supported further by arguments from the analysis of non-verbal elements within complex predicates.

List of References

- Åfarli, T. A. and K. M. Eide 2000. 'Subject requirement and predication'. *Nordic Journal of Linguistics* 23: 27-48.
- Alexiadou, A. 1997. *Adverb Placement: A Case Study in Antisymmetric Syntax*. Amsterdam: Benjamins.
- Ameen, N. A. 1960. *Rêzmanî Kurdî (A Kurdish Grammar)*. Sulaimani, Kurdistan.
- Amin, W.O. 2004. *chand âsôyaki trî zimânawânî 'Other Horizons of Linguistics'*. Erbil: Aras Press.
- Arad, M. 1999. 'On little *v*'. *MIT Working Paper in Linguistics* 33: 1-25.
- Bak, J. 2011. *The Light Verb Construction in Korean*. PhD thesis, University of Toronto.
- Baker, M. 1985. 'The mirror principle and morphosyntactic explanation'. *Linguistic Inquiry* 16: 373-415.
- Baker, M. 1988. *Incorporation: A Theory of Grammatical Function Changing*. Chicago: University of Chicago Press.
- Baker, M. 2003. *Lexical Categories: Verbs, Nouns, and Adjectives*. Cambridge: Cambridge University Press.
- Baker, M. 2013. 'On agreement and its relation to case: Some generative ideas and results'. *Lingua* 130: 14-32.
- Baker, M. and Ü. Atlamaz. (in progress). 'On the relationship of case to agreement in split-ergative Kurmanji'.
- Bejar, S. and M. Rezac. 2009. 'Cyclic agree'. *Linguistic Inquiry* 40 (1): 35-73.
- Belletti, A. 1990. *Generalized Verb Movement*. Torino: Rosenberg and Sellier.
- Belletti, A. 1994. 'Verb positions: evidence from Italian'. In D. Lightfoot and N. Hornstein (eds) *Verb Movement*. Cambridge, UK: Cambridge University Press. 19-40.
- Biberauer, T., A. Holmberg and I. Roberts 2014. 'A syntactic universal and its consequences'. *Linguistic Inquiry* 45 (2): 169-225.
- Bittner, M. and K. Hale. 1996. 'Ergativity: Toward a theory of heterogenous class'. *Linguistic Inquiry* 27: 531-604.
- Bobaljik, J. 2008. 'Where's Phi? Agreement as a Post-syntactic Operation'. In D. Adger, D. Harbour, and S. Béjar *Phi Theory: Phi Features Across Interfaces and Modules*. Oxford: Oxford University Press. 295-328.

- Borer, H. 1984. *Parametric Syntax: Case Studies in Semitic and Romance Languages*. Dordrecht: Foris.
- Bowers, J. 1993. 'The syntax of predication'. *Linguistic Inquiry* 24 (4): 591-656.
- Bowers, J. 2002. 'Transitivity'. *Linguistic Inquiry* 33(2): 183-224.
- Butt, M. 1995. *The Structure of Complex Predicates in Urdu*. Stanford, California: CSLI Publications.
- Butt, M. 2003. 'The light verb jungle'. Paper presented at *Workshop on Multi-Verb Constructions*. Trondheim.
- Butt, M. and G. Ramchand. 2005. 'Complex aspectual structure in Hindi/Urdu'. In N. Ertischik-Shir and T. Rappaport (eds) *The Syntax of Aspect*. Oxford: Oxford University Press. 117-153.
- Butt, M. and A. Lahiri. 2013. 'Diachronic pertinacity of light verbs'. *Lingua* 135: 7-29.
- Bybee, J. 1985. *Morphology: A Study of the Relation between Meaning and Form*. Amsterdam: John Benjamins.
- Bynon, T. 1979. 'The ergative construction in Kurdish'. *Bulletin of the School of Oriental and African Studies* 42(02). 211-224.
- Bynon, T. 1980. 'From passive to active in Kurdish via the ergative construction'. In E. C. Traugott, R. Labrum, and S. Shepherd (eds) *Papers from the 4th International Conference on Historical Linguistics*. Amsterdam: Benjamins. 151-163.
- Cardinaletti, A. 2004. 'Towards a cartography of subject positions'. In L. Rizzi (ed.) *The Structure of CP and IP*. New York: Oxford University Press. 115-165.
- Cattell, R. N. 1984. *Syntax and Semantic 17: Composite Predicates in English*. New York, NY: Academic Press.
- Chafe, L.W. 1970. *Meaning and the Structure of Language*. Chicago: University of Chicago Press.
- Chodzko, A. 1857. 'Etudes philologiques sur la langue Kurde: Dialecte de Soleimanie'. *Journal Asiatique* 9: 297-356.
- Chomsky, N. 1970. 'Remarks on nominalization.' In R. A. Jacobs and P.S. Rosenbaum (eds.) *Readings in English Transformational Grammar*. Waltham, MA: 184-221.
- Chomsky, N. 1981. *Lectures on Government and Binding*. Dordrecht: Foris.
- Chomsky, N. 1989. 'Some notes on economy of derivation and representation'. *MIT Working Papers in Linguistics* 10: 42-74.
- Chomsky, N. 1993. 'A minimalist program for linguistic theory.' In K. Hale and S. J. Keyser (eds.) *The View from Building 20*. MIT Press. 1-52.

- Chomsky, N. 1994. 'Bare phrase structure'. *MIT Occasional Papers in Linguistics* 5. Cambridge, MA: Department of Linguistics and Philosophy, MIT.
- Chomsky, N. 1995. *The Minimalist Program*. Cambridge, MA: The MIT Press.
- Chomsky, N. 2000. 'Minimalist inquiries: The framework'. In R. Martin, D. Michaels, & J. Uriagereka (eds) *Step by Step: Essays on Minimalist Syntax in Honor of Howard Lasnik*. Cambridge, MA: The MIT Press. 89-155.
- Chomsky, N. 2001a. 'Derivation by phase'. In M. Kenstowicz (ed.) *Ken Hale. A Life in Language*. Cambridge, MA: The MIT Press. 1-52.
- Chomsky, N. 2001b. 'Beyond explanatory adequacy'. *MIT Occasional Papers in Linguistics* 20: Cambridge, MA: Department of Linguistics and Philosophy, MIT. 1-28.
- Cinque, G. 1999. *Adverbs and Functional Heads*. Oxford: Oxford University Press.
- Collins, C. 2007. 'Home sweet home'. *NYU Working Papers in Linguistics* 1: 1-34.
- Cuervo, M. C. 2003. *Datives at large*. PhD thesis, MIT.
- Cummins, S. and Y. Roberge 1994. 'Romance Inflectional Morphology In and Out of Syntax'. *MIT Working Papers in Linguistics* 22: 53-70.
- De Morgan, J. 1904. *Etudes Linguistiques: Dialectes Kurdes*. Paris: Ernest Leroux.
- Diesing, M. 1998. 'Light verbs and the syntax of aspect in Yiddish'. *The Journal of Comparative Germanic Linguistics* 1: 119-156.
- Dixon, R. M. W. 1994. *Ergativity*. Cambridge: Cambridge University Press.
- Dorleijn, M. 1996. *The Decay of Ergativity in Kurmanci*. Tilburg: Tilburg University Press.
- Edwards, B. B. 1851. 'Note on the Kurdish language'. *Journal of the American Oriental Society* 2: 120-123.
- Everett, D. 1996. *Why there are no Clitics. An Alternative Perspective on Pronominal Allomorphy*. University of Texas, Arlington: SIL.
- Fattah, M. M. 1997. *A Generative Grammar of Kurdish*. PhD thesis, University of Amsterdam.
- Folli, R., H. Harley and S. Karimi. 2005. 'Determinants of event type in Persian complex predicates'. *Lingua* 115: 1365-1401.
- Folli, R. and Harley, H. (to appear). 'The syntax of argument structure: Evidence from Italian complex predicates'. *Journal of Linguistics* 49.
- Fossum, L. O. 1919. *A Practical Kurdish Grammar*. Minneapolis, Minnesota: The Inter-Synodical Ev. Lutheran Orient-Mission Society.

- Friend, R. 1985. *Some Syntactic and Morphological Features of Suleimaniye Kurdish*. PhD thesis, UCLA.
- Fuß, E. 2005. *The Rise of Agreement: A Formal Approach to the Syntax and Grammaticalization of Verbal Inflection*. Amsterdam/Philadelphia: John Benjamins Publication Company.
- Ghameshi, J. and D. Massam. 1994. 'Lexical/syntactic relations without projections'. *Linguistic Analysis* 23(3-4): 175-217.
- Grimshaw, J. and A. Mester. 1988. 'Light verbs and theta-marking'. *Linguistic Inquiry* 19 (2): 205-232.
- Haegeman, L. and R. Zanuttini 1991. 'Negative heads and the Neg-Criterion'. *Linguistic Review* 8: 233-252.
- Haegeman, L. 1995. *The Syntax of Negation*. Cambridge, MA: Cambridge University Press.
- Haegeman, L. 2000. 'Remnant Movement and OV Order'. In P. Svenonius (ed.) *The Derivation of VO and OV*. Amsterdam: John Benjamins. 69-96.
- Haig, G. 2002. 'Noun-plus-verb complex predicates in Kurmanji Kurdish: argument sharing, argument incorporation, or what?' *Sprachtypologie und Universalienforschung: STUF, Berlin* 55 (1): 15-48.
- Haig, G. 2004. *Alignment in Kurdish: A Diachronic Perspective*. Habilitationsschrift. Christian-Albrechts-Universität zu Kiel, Germany.
- Haig, G. 2008. *Alignment Change in Iranian Languages. A Construction Grammar Approach*. Berlin: Mouton de Gruyter.
- Haig, G. (in progress). 'Ergativity in Iranian'.
- Haig, G. and Öpengin, E. 2014. 'Kurdish: A critical research overview'. *Kurdish Studies* 2: 99-122.
- Hale, K. and S. J. Keyser. 1993. 'On argument structure and the lexical expression of syntactic relations'. In Hale, K. and S. J. Keyser (eds) *The View from Building 20*. MIT Press. 53-109.
- Hale, K. and S. J. Keyser. 2002. *Prolegomenon to a Theory of Argument Structure*. Cambridge, MA: MIT Press.
- Halle, M. and A. Marantz. 1993. 'Distributed Morphology and the pieces of inflection'. In K. Hale and S. J. Keyser (eds) *The View from Building 20*. Cambridge, MA: MIT Press. 111-176.
- Harley, H. 1995. *Subjects, Events and Licensing*. PhD thesis, MIT.

- Harley, H. (to appear). 'The syntax/morphology interface.' In Alexiadou and Kiss (eds), *Handbook of Syntax*, Mouton.
- Haspelmath, M. 1993. *A Grammar of Lezgian*. Berlin: Mouton de Gruyter.
- Hawkins, J. and G. Gilligan. 1988. 'Left--right asymmetries in morphological universals'. In J. Hawkins and H. Holmback (eds.) *Lingua (Special Issue: Papers in Universal Grammar)* 74: 219-259.
- Holmberg, A. and C. Platzack. 1995. *The Role of Inflection in Scandinavian Syntax*. Oxford: Oxford University Press.
- Holmberg, A. 2000. 'OV order in Finnish'. In P. Svenonius (ed.) *The Derivation of VO and OV*. Amsterdam: John Benjamins. 123-152.
- Holmberg, A. 2004. 'Ergativity and clitics in the Iranian languages in a minimalist perspective'. Newcastle University.
- Holmberg, A. and D. Odden. 2004. 'Ergativity and role-marking in Hawrami'. *Syntax of the World's Languages (SWL 1)*. Leipzig, Germany.
- Holmberg, A. and I. Roberts 2013. 'The syntax-morphology relation'. *Lingua* 130: 111-131.
- Horn, L. and Y. Kato. 2000. *Negation and Polarity*. Oxford: Oxford University Press.
- Houtun-Schinder, A. 1884. 'Beiträge zum kurdischen Wortschatze'. *ZDMG* 38: 43-116.
- Jackendoff, R. 1990. *Semantic Structure*. Cambridge, MA: MIT Press.
- Jayaseelan, K. A. 2010. 'Stacking, Stranding, and Pied-Piping: A Proposal about Word Order'. *Syntax* 13: 298-330.
- Jespersen, O. 1965. *A Modern English Grammar on Historical Principles, Part VI, Morphology*. London, UK: George Allen and Unwin Ltd.
- Jügel, T. 2009. 'Ergative remnants in Sorani Kurdish?'. *Orientalia Suecana* 58: 142-158.
- Julien, M. 2000. *Syntactic Heads and Word Formation: A study of Verbal Inflection*. PhD Thesis, University of Tromsø.
- Julien, M. 2001. 'The syntax of complex tenses.' *Linguistic Review* 18: 123-165.
- Julien, M. 2002. *Syntactic Heads and Word Formation*. New York: Oxford University Press.
- Karimi-Doostan, Gh. 1997. *Light Verb Constructions in Persian*. PhD thesis, University of Essex.
- Karimi-Doostan, Gh. 2001. 'N+V complex predicates in Persian'. In N. Dehe and A. Wanner (eds) *Structural Aspects of Semantically Complex Verbs*. Peterlang, Frankfurt. 277-292.

- Karimi-Doostan, Gh. 2005. 'Light verbs and structural case'. *Lingua* 115: 1737-1756.
- Karimi-Doostan, Gh. 2011. 'Separability of light verb construction in Persian'. *Studia Linguistica* 65(1): 70-95.
- Karimi, S. 2013. 'Introduction'. *Lingua* 135: 1-6.
- Karimi, Y. 2007. 'Kurdish ezafe construction: implications for DP structure'. *Lingua* 117: 2159-2177.
- Karimi, Y. 2010. 'Unaccusative transitives and the Person-Case Constraint effects in Kurdish'. *Lingua* 120: 693-716.
- Karimi, Y. 2013. 'Extending defective intervention effects'. *The Linguistic Review* 30(1): 51-78.
- Katamba, F. 1993. *Morphology*. New York, NY: Palgrave Macmillan.
- Kayne, R. S. 1994. *The Antisymmetry of Syntax*. Cambridge, MA: The MIT Press.
- Kearns, K. 1989. 'Predicate nominals in complex predicates'. *MIT Working Papers in Linguistics* 10: 123-134.
- Kim, S.W. 1994. 'A study of light verb constructions'. *Language Research* 30: 137-159.
- Koopman, H. and A. Szabolcsi. 2000. *Verbal Complexes*. Cambridge, MA: MIT Press.
- Korn, A. 2009. 'Western Iranian pronominal clitics'. *Orientalia Suecana* 58: 159-171.
- Kornfilt, J. 1997. *Turkish*. London: Routledge.
- Kratzer, A. 1996. 'Severing the external argument from its verb'. In Rooryck, J. and A. Zaring (eds.) *Phrase Structure and the Lexicon*. Dordrecht: Kluwer Academic Publishers. 109-137.
- Laka, I. 1990. *Negation in Syntax: On the Nature of Functional Categories and Projections*. PhD thesis, MIT.
- Laka, I. 1994. *On the Syntax of Negation*. New York: Garland Publishing.
- Larson, R. 1988. 'On the double object construction'. *Linguistic Inquiry* 19: 335-91.
- Legate, J. A. 2008. 'Morphological and abstract case'. *Linguistic Inquiry* 39: 55-101.
- Legate, J. A. 2012. 'Types of ergativity'. *Lingua* 212: 181-191.
- Lewis, M. Paul, Gary F. Simons, and Charles D. Fennig (eds.) 2014. *Ethnologue: Languages of the World*. 17th ed. Dallas, Texas: SIL International. Last accessed 15 July 2015, from: <http://www.ethnologue.com/17/>
- Lomashvili, L. 2011. *Complex Predicates: the Syntax-morphology Interface*. Amsterdam: John Benjamins.
- Mackenzie, D. N. 1961. *Kurdish Dialect Studies*. London: Oxford University Press.

- Mahmoud, L. 1994. *Kurdish Personal Affixes*. MA dissertation, University of Texas at El Paso.
- Mann, O. 1906. *Die Mundart der Mukri-Kurden*. Berlin: Georg Reimer.
- Marantz, A. 1997. 'No escape from syntax: don't try morphological analysis in the privacy of your own lexicon'. In A. Dimitriadis and L. Siegel (eds.) *University of Pennsylvania Working Papers in Linguistics* 4.2: 201-225.
- Marantz, A. 2000. 'Roots: the universality of root and pattern morphology', paper presented at the Conference on Afro-Asiatic Languages, Université de Paris VII.
- Matras, Y. 1992. 'Ergativity in Kurmanji (Kurdish)'. *Orientalia Suecana* 41: 139-154.
- McCarus, E. 1958. *A Kurdish Grammar: Descriptive Analysis of Kurdish of Suleimaniya, Iraq*. New York: American Council of Learned Societies.
- McCarus, E. 2009. 'Kurdish'. In G. Windfuhr (ed.) *The Iranian Languages*. London: Routledge. 587-633.
- Megerdooian, K. 2001. 'Event structure and complex predicates in Persian'. *Canadian Journal of Linguistics* 46: 97-125.
- Megerdooian, K. 2012. 'The status of the nominal in Persian complex predicates'. *Natural Language and Linguistic Theory* 30: 179-216.
- Mendivil Giró, J.L. 2012. 'Ergativity as transitive unaccusativity'. *Folia Linguistica*, 46(1): 171-210.
- Mohammad, J. and S. Karimi. 1992. 'Light verbs are taken over: Complex verbs in Persian'. *Proceedings of WECOL* 5: 195-212.
- Mohanan, T. 1995. *Arguments in Hindi*. Stanford, CA: CSLI.
- Nebez, J. 1976. *Zimanê Yekgirtûy Kurdî (A Unified Kurdish Language)*. Amberg, West Germany: NUKSE.
- Öpengin, E. 2012. 'Adpositions and argument indexing in the Mukri variety of Central Kurdish: Focus on ditransitive constructions'. *Orientalia Suecana* 61: 187-198.
- Öpengin, E. 2013. *Clitic-Affix Interactions: A Corpus-based Study of Person Marking in the Mukri Variety of Central Kurdish*. PhD thesis, Université Sorbonne Nouvelle and Universität Bamberg.
- Ouhalla, J. 1991. *Functional Categories and Parametric Variation*. London: Routledge.
- Panagiotidis, P. 2014. *Categorial features: A Generative Theory of Word Class Categories*. Cambridge: Cambridge University Press.

- Pantcheva, M. 2008. 'Noun preverbs in Persian Complex Predicates'. In P. Svenonius and G. Ramchand (eds). *Tromsø Working Papers on Language & Linguistics: Nordlyd 35, Special Issue on Complex Predication*. 1-27.
- Pantcheva, M. 2009. 'First phase syntax of Persian complex predicates: Argument structure and telicity'. *Journal of South Asian Linguistics* 2(1): 53-72.
- Preminger, O. 2011. *Agreement as a Fallible Operation*. Cambridge, MA: MIT Press.
- Pollock, J. 1989. 'Verb movement, Universal Grammar, and the structure of IP'. *Linguistic Inquiry* 20: 365-424.
- Rezac, M. 2003. 'The fine structure of cyclic Agree'. *Syntax* 6: 156-182.
- Rizzi, L. 1997. 'The fine structure of the left periphery'. In Liliane Haegeman (ed.) *Elements of Grammar*. Kluwer, Dordrecht. 281-337.
- Roberts, I. 2001. 'Head Movement'. In Baltin, M. and Collins, C. (eds) *Handbook of Syntactic Theory*. Oxford: Blackwells: 113-147.
- Roberts, I. 2010. *Agreement and Head Movement: Clitics, Incorporation, and Defective Goals*. Cambridge, MA: MIT Press.
- Roberts, I. (to appear). 'Head Movement and the Minimalist Program'. In Boeckx, C. (ed) *The Oxford Handbook of Minimalism*. Oxford: Oxford University Press.
- Rosen, S.T. 1989. 'Two types of noun incorporation: A lexical analysis'. *Language* 65 (2): 294-317.
- Samvelian, P. 2001. 'Le statut syntaxique des objets nus en persan'. *Bulletin de la Société de Linguistique de Paris* 96: 349-388.
- Samvelian, P. 2006. 'A lexicalist account of Sorani Kurdish prepositions'. In S. Müller (ed.) *Proceedings of the HPSG07 Conference*. Stanford: CSLI Publications.
- Samvelian, P. 2007. 'What Sorani Kurdish absolute prepositions tell us about cliticization'. In *Texas Linguistic Society IX: The Morphosyntax of Underrepresented Languages*. Stanford: CSLI Publications. 263-283.
- Sato, Y. 1993. *Complex Predicate Formation with Verbal Nouns in Japanese and Korean: Argument Transfer at LV*. PhD thesis, University of Hawaii.
- Schütze, C. 2004. 'Synchronic and diachronic microvariation in English *do*'. *Lingua* 114: 495-516.
- Sigurðsson, H. Á. 2011. 'On UG and materialization'. *Linguistic Analysis* 37: 367-388.
- Soane, E. B. 1913. *Grammar of Kurmanji or Kurdish Language*. London: Luzac & Co.
- Speas, M. J. 1986. *Adjunctions and Projections in Syntax*. PhD thesis, MIT.

- Speas, M. 1991. 'Functional heads and inflectional morphology'. *The Linguistic Review* 8: 389-417.
- Spencer, A. 1997. 'Inflectional morphology and functional heads'. In W. Dressler, M. Prinzhorn, and J. Rennison (eds.) *Advances in Morphology*. Berlin: Mouton de Gruyter. 31-49.
- Svenonius, P. 2006. '1 ... 3-2.' Oxford Handbooks Online. Oxford University Press.
- Thackston, W. M. 2006. *Sorani Kurdish: A Reference Grammar with Selected Readings*. Last accessed 10 July 2015, from:
<http://www.fas.harvard.edu/~iranian/Sorani/>
- Travis, L.M. 1984. *Parameters and Effects of Word Order Variation*. PhD thesis, MIT.
- Tsujimura, N. 1996. *An Introduction to Japanese Linguistics*. Oxford: Blackwell.
- Vahedi-Langrudi, M. 1996. *The Syntax, Semantics, and Argument Structure of Complex Predicates in Modern Farsi*. Ottawa, ON: University of Ottawa.
- Woolford, E. 2015. 'Ergativity and transitivity'. *Linguistic Inquiry* 46: 489-531.
- Zangana, M. M. 1989. *Kar u Erkî le Sîntaksda (Verb and its function in Syntax)*. MA dissertation. University of Salahaddin.
- Zwicky, A. M. and G. K. Pullum. 1983. 'Cliticization versus inflection: English n't'. *Language* 59: 502-513.